



SUIVEZ-NOUS

conseils, actualités, nouveautés, concours, ...



Guide d'installation et d'utilisation

DC 35 / DC 55 / DC 75 / DC 95 / DC 115



1, avenue de Londres, 13127 Vitrolles, FRANCE

Tel : + 33 4 28 70 69 99

info@warmpac.fr

www.wpool.fr

Langues

Français : 3 - 35

English : 36 - 68

Español : 69 - 101

Deutsch : 102 - 134

Italiano : 135 - 167

Português : 135 - 167

Avertissement



Avant installation vérifiez l'état de votre pompe à chaleur dès réception et émettez les réserves d'usage. En cas de doute ou de problèmes faites un courrier AR à votre installateur ou contactez le fabricant dans un délai de 48h. Passé ce délai, aucune réclamation ne pourra être acceptée.

Afin d'offrir à nos clients des produits fiables et de qualité, il a été fabriqué selon des normes de fabrication et de production strictes.

Ce manuel comprend l'ensemble des informations nécessaires à l'installation, au dépannage et à l'entretien de l'appareil. Veuillez-vous reporter à ce manuel avant toute intervention d'entretien ou d'utilisation de cette unité.

L'installation et la mise en service de votre appareil doivent être réalisées par un personnel spécialisé et qualifié dans le respect des normes de sécurité en vigueur. Veillez à lire attentivement cette notice. Nous ne serons en aucun cas tenus pour responsables en cas de blessure ou d'endommagement de la machine suite à d'éventuelles erreurs lors de l'installation. Le non-respect de ces instructions entrainera une perte de garantie.



N'utilisez que des pièces détachées d'origine du constructeur, le non-respect de cette condition entrainera une perte de garantie.

Votre unité de pompe à chaleur doit exclusivement servir pour chauffer une piscine. Son utilisation est réservée à la montée en chauffe et au maintien de la température d'un bassin dans des conditions prédéterminée par un bilan thermique à effectuer auprès d'un revendeur avant le choix de la pompe à chaleur.

Cette pompe à chaleur respecte les normes de fabrication et de communication définies par le DTP10 de la FPP et NFPAC.

ATTENTION :

N'utilisez pas de moyens ou de procédés dans le but d'accélérer le dégivrage ou le nettoyage de votre pompe à chaleur. Ne pas percer ou bruler ou placer à proximité d'une source de combustion. Le gaz réfrigérant ne doit pas contenir d'odeur forte.

Cet appareil n'est pas fait pour être utilisé par des enfants ou des personnes dont les capacités physiques ou mentales sont réduites sans supervision car cela peut entrainer des blessures graves ou mortelles.

Toute intervention sur cet appareil doit être réalisée par un personnel qualifié, le fabricant et le distributeur ne pourront en aucun cas être tenu pour responsable des dommages matériels et / ou corporels occasionné par une mauvaise utilisation / installation.

L'installation doit répondre aux normes électriques locales et être correctement reliée à la terre. L'appareil doit être obligatoirement disjoncté avant toute intervention.

Directive 2002/96/CE (WEEE) :

Le symbole représentant une poubelle barrée qui se trouve sous l'appareil indique que ce produit, à la fin de sa vie utile, doit être traité séparément des déchets ménagers, doit être apporté à un centre de recyclage des appareils électriques et électroniques ou remis au revendeur lors de l'achat d'un appareil équivalent.

Directive 2002/95/CE (RoHs) : Ce produit est conforme à la directive 2002/95/CE (RoHs) concernant la limitation de l'utilisation de substances nocives dans les appareils électriques et électroniques.

L'installation d'un disjoncteur est nécessaire afin de prévenir les risques d'incendie et de chocs électriques. Si l'alimentation électrique est endommagée merci de la faire remplacer par un professionnel afin d'éviter les risques corporels et matériels.

1.



Caractéristiques techniques

Modèle - Reference		DC35	DC55	DC75	DC95	DC115
Capacité bassin - pool capacity	Maxi	35m ³	55m ³	75m ³	95m ³	115m ³
Puissance de chauffage* - Heating consumption	kW	1.4- 6.8	1.3- 7.93	1.75- 10.90	3.21-15.81	3.21- 17.05
Consommation* - Consumption	kW	0.14- 1.51	0.12- 1.37	0.16- 1.96	0.31- 3.03	0.32- 3.98
COP *		10.0 -45	11.24-5.79	10.88- 5.56	10.3-5.22	10.01-4.82
<p>* FR : Test réalisé à 27°C de température d'air, avec le même écart de température et de débit d'eau obtenu à 15°C. EN : Test carried out at 27 °C air temperature, with the same difference in temperature and water flow obtained at 15 °C.</p>						
Courant nominal - Rated current	A	1.02-5.18	0.9-6.0	1.2-8.6	1.5-13.3	2.0-17.5
Puissance de chauffage** - Heating consumption	kW	1.1- 5.2	0.96 - 6.46	1.52- 8.21	2.3- 12.14	2.07- 15.20
Consommation** - Consumption	kW	0.21- 1.24	0.19- 1.32	0.25- 1.84	0.37- 2.80	0.38- 3.60
<p>** FR : Test réalisé à 15°C de température d'air, avec une entrée d'eau à 26°C et une sortie d'eau à 28°C afin de définir le débit d'eau, la capacité de chauffe et la consommation, selon les normes FPP. EN : Test carried out at 15 °C air temperature, with a water inlet at 26 °C and a water outlet at 28 °C in order to define the water flow rate, the heating capacity and the consumption, according to FPP standards.</p>						
Puissance en froid *** - Cold power consumption	kW	2.2	3.72	4.3	6.2	7.69
Consommation*** - Consumption	kW	1.4	1.45	1.78	3.3	2.66
COP***		1.55	2.57	2.43	1.86	2.89
<p>*** FR : Test réalisé à 35°C de température d'air, avec une entrée d'eau à 30°C et une sortie d'eau à 29°C. EN : Test performed at 35 °C air temperature, with water inlet at 30 °C and water outlet at 29 °C.</p>						
Carrosserie - Body		ASA	ASA	ASA	ASA	ASA
Contrôleur - Controller		Ecran Digital tactile - Digital Touch screen				
Gaz		R32	R32	R32	R32	R32
Echangeur - Exchanger		Titane Twisté - Twisted Titanium	Titane Twisté - Twisted Titanium	Titane Twisté - Twisted Titanium	Titane Twisté - Twisted Titanium	Titane Twisté - Twisted Titanium
Compresseur - Compressor		Rotatif Panasonic - Panasonic Rotary	Rotatif Panasonic - Panasonic Rotary	Rotatif Panasonic - Panasonic Rotary	Rotatif Mitsubishi - Mitsubishi Rotary	Rotatif Mitsubishi - Mitsubishi Rotary

Nombre de ventilateurs - ventilation units		1	1	1	1	1
Vitesse de rotation du ventilateur (PRM) - Ventilation rotation speed	T/mn	400-700	400-750	400-800	300-750	400-750
Mode		Chaud/Froid/Auto Warm/Cold/Auto	Chaud/Froid/Auto Warm/Cold/Auto	Chaud/Froid/Auto Warm/Cold/Auto	Chaud/Froid/Auto Warm/Cold/Auto	Chaud/Froid/Auto Warm/Cold/Auto
Plage de fonctionnement - Operating range		-5°C-43°C	-5°C-43°C	-5°C-43°C	-5°C-43°C	-5°C-43°C
Puissance acoustique à 1m - Noise	dB(A)	38-50	41-50	42-51	42-55	45-56
Alimentation		Mono 220-240V/50HZ				
Détendeur - Regulator		Electronique - Electronic	Electronique - Electronic	Electronique - Electronic	Electronique - Electronic	Electronique - Electronic
Débit d'eau - Water flow	m ³ /H	2.5	2.7	3.5	5.2	5.6
Dimension unite - unit dimension	mm	1000/418/605	1000/418/605	1000/418/605	1046/453/767	1160/490/862
Dimension carton (l/L/h) - Package dimensions	mm	1030/435/615	1030/435/615	1030/435/615	1130/480/780	1210/510/880
Poids net / poids brut - NW/GW	kg	43/54	47/58	51/62	66/79	74/88
Garantie toutes pieces - warranty		3 ans 3 years	3 ans - 3 years	3 ans - 3 years	3 ans - 3 years	3 ans - 3 years

2. Dimensions de la pompe à chaleur

Cotes : DC 35 – DC 55 – DC 75

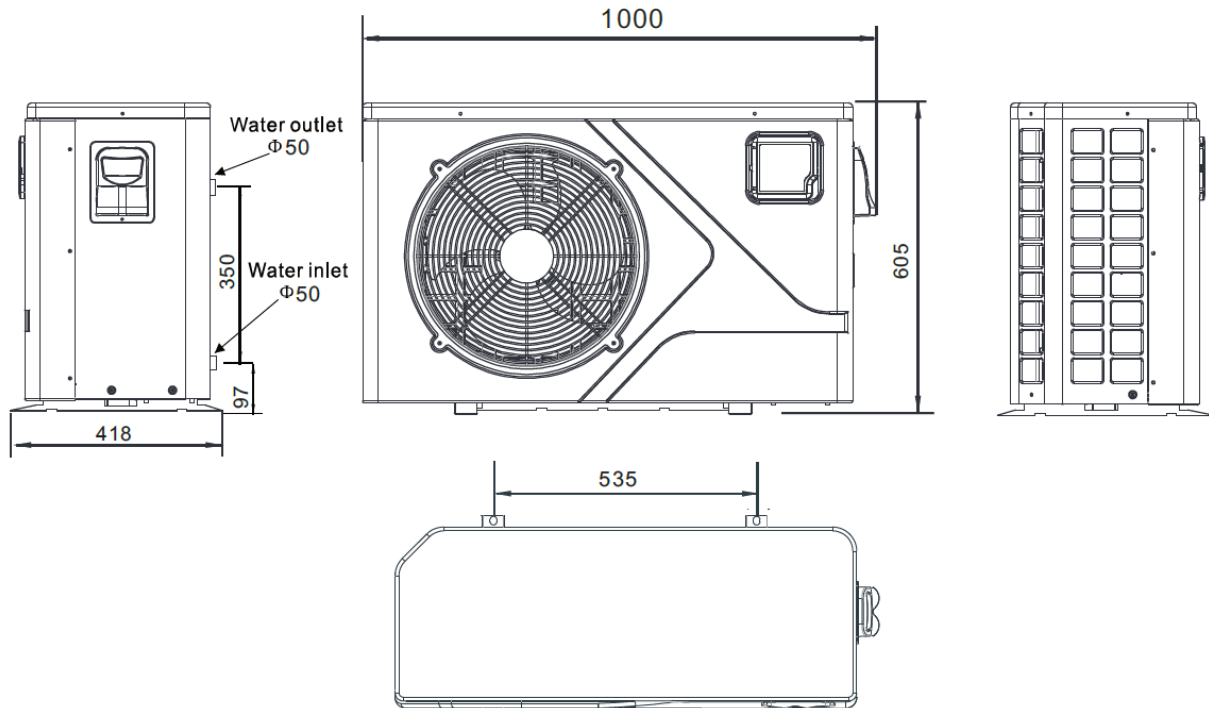

Cotes : DC 95 :

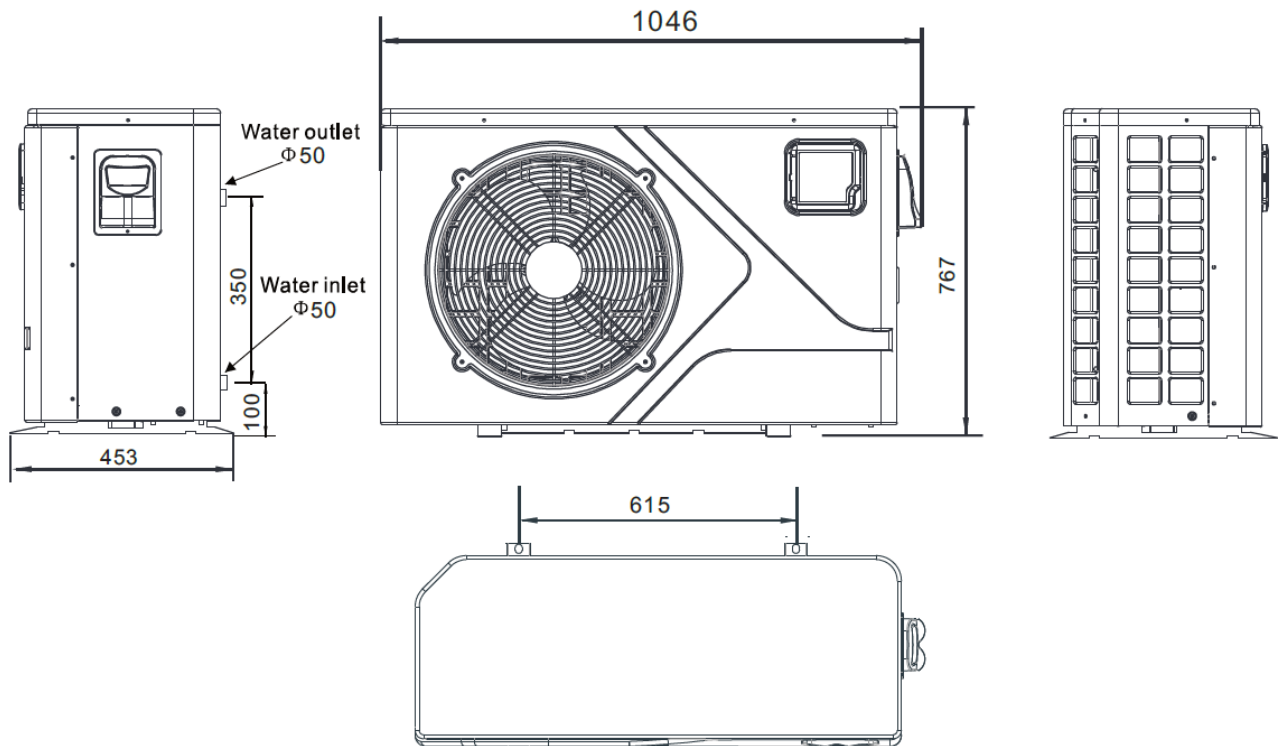

Cotes : DC115

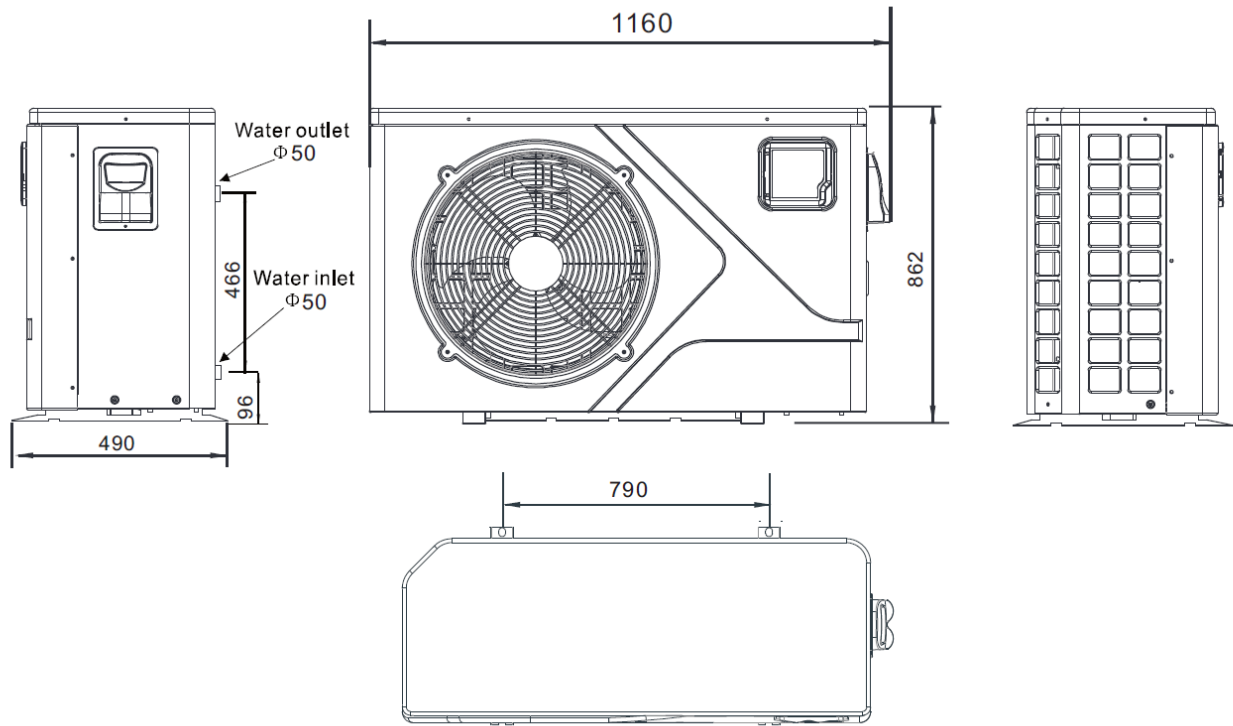

3. Installation et raccords

Lors de la première utilisation, assurez-vous que la piscine soit remplie d'eau

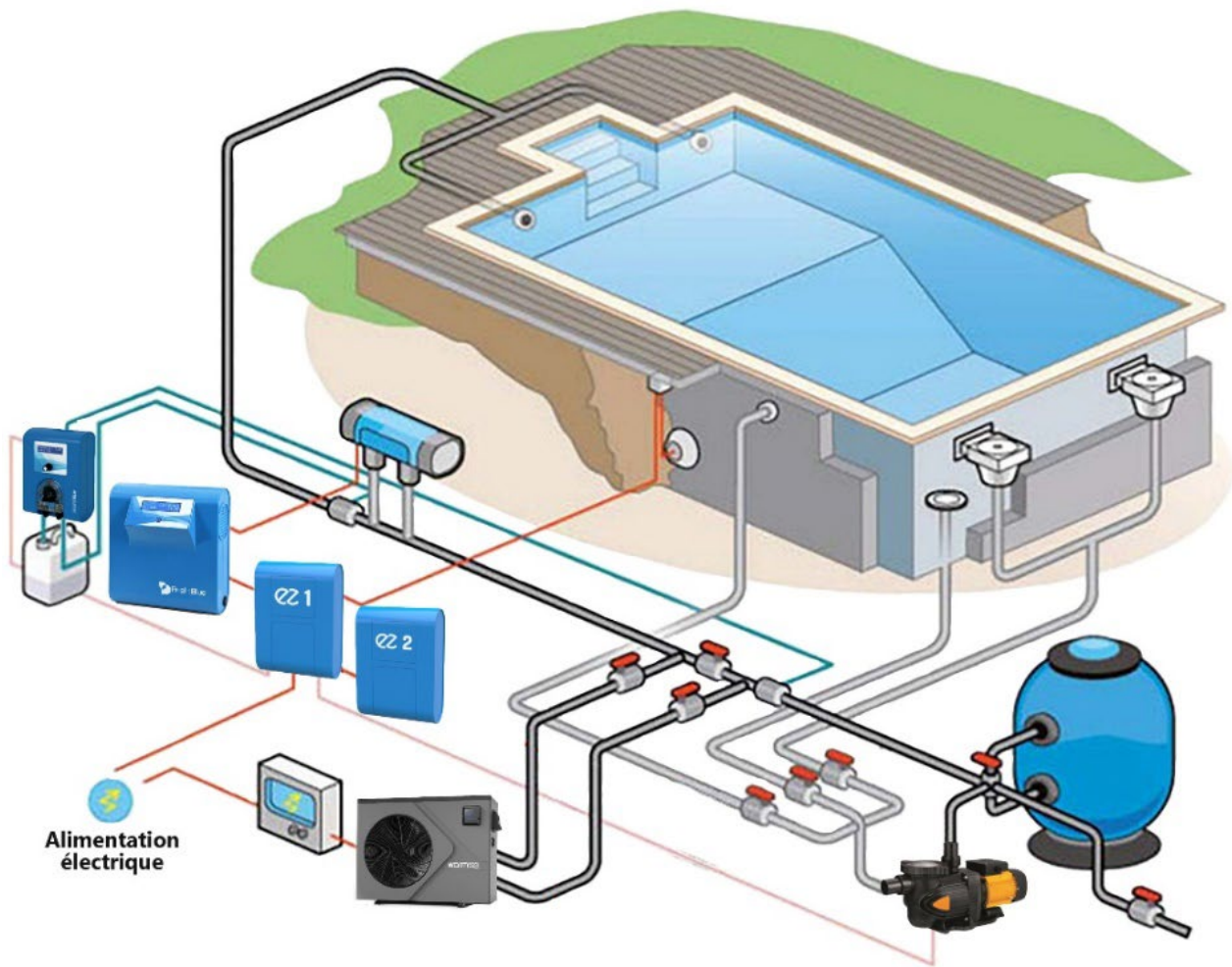

Le choix de votre pompe à chaleur doit avoir été déterminée par un bilan thermique personnalisé afin d'être certain que ses caractéristiques correspondront à vos besoins. La société ne pourra en aucun cas être tenue pour responsable en cas de mauvaises performances si son dimensionnement n'a pas été réalisé grâce à un bilan thermique personnalisé et si les conditions d'utilisation indiquées lors du bilan thermique n'ont pas été respectées.

Votre pompe à chaleur doit être placée à l'extérieur et doit respecter les distances minimales de 3m sans obstacle devant la soufflerie- 50 cm du mur pour l'arrière et 15cm au-dessus du sol.

Nous vous recommandons d'utiliser des plots et de faire évacuer vos condensats sur un tout venant (qui pourra être recouvert de graviers).

Si une de ces recommandations n'est pas appliquée ou applicable, nous vous demandons de prendre contact avec le fabricant pour vérifier si l'installation réalisée ou souhaitée sera sans incidence au bon fonctionnement de votre pompe à chaleur.

3.1 Raccordement hydraulique

L'échangeur de chaleur en titane à débit exclusif de la pompe à chaleur piscine ne nécessite aucune disposition particulière de la plomberie, à l'exception du bypass. (Veuillez régler le débit en fonction de la plaque signalétique). La chute de pression de l'eau est inférieure à 10kPa au débit maximal. Comme il n'y a pas de chaleur résiduelle ou de température de flamme, l'unité ne nécessite pas de tuyauterie de dissipation de chaleur en cuivre. Des tuyaux en PVC peuvent être installés directement sur l'unité.

Emplacement : Connectez l'unité dans la ligne de décharge (retour) de la pompe de la piscine, en aval de toutes les pompes de filtration et de la piscine, et en amont de tous les chlorinateurs, ozonateurs ou pompes chimiques. Le modèle standard est équipé de raccords à colle glissante qui acceptent les tuyaux en PVC de 32 mm ou 50 mm pour le raccordement à la tuyauterie de filtration de la piscine ou du spa.

Considérez sérieusement l'ajout d'un raccord rapide à l'entrée et à la sortie de l'unité pour permettre une vidange facile de l'unité pour l'hivernage et pour fournir un accès plus facile si un entretien est nécessaire.

Condensation : Comme la pompe à chaleur refroidit l'air d'environ 4 à 5 degrés, l'eau peut se condenser sur les ailettes de l'évaporateur. Si l'humidité relative est très élevée, cela peut représenter plusieurs litres par heure. L'eau s'écoulera le long des ailettes dans le bassin de base et sera évacuée par le raccord d'évacuation de la condensation en plastique barbelé situé sur le côté du bassin de base.

Ce raccord est conçu pour accepter un tube en vinyle transparent de 20 mm qui peut être poussé à la main et dirigé vers une évacuation appropriée. Il est facile de confondre la condensation avec une fuite d'eau à l'intérieur de l'unité.

NB : Une façon rapide de vérifier que l'eau est de la condensation est d'arrêter l'unité et de laisser la pompe de la piscine en marche. Si l'eau cesse de s'écouler du bassin, il s'agit de condensation.

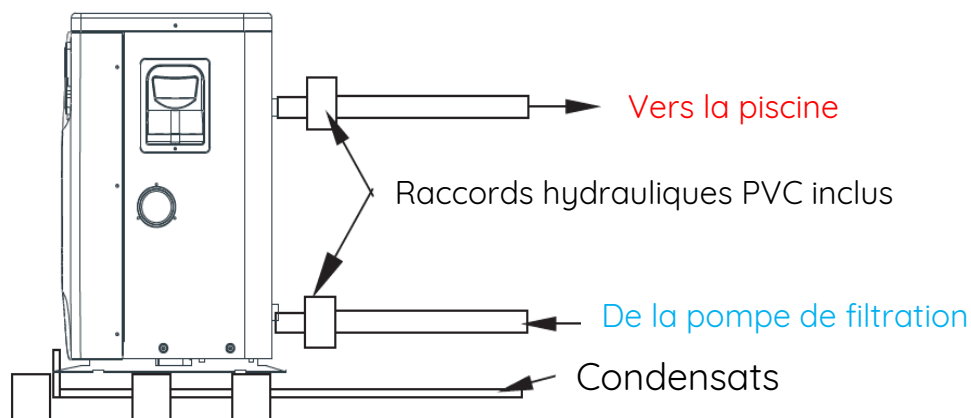

3.2 Raccordement électrique



Important : Le raccordement de votre pompe chaleur doit être réalisé par du personnel habilité et qualifié pour le faire. Vérifiez que le câble alimentant le local technique soit d'une section suffisante pour supporter la consommation supplémentaire exigée par la machine.

La PAC doit être alimentée à partir d'un disjoncteur **courbe D**, indépendant qui peut être soit sur le tableau électrique principal équipé d'un différentiel soit sur un tableau indépendant relié au tableau principal, qui aura un différentiel. Si ce n'est pas le cas ajouter un différentiel au tableau indépendant de votre PAC.

Référence /Reference	Alimentation	Puissance disjoncteur courbe D / D-Curve circuit breaker power	Section de câble selon la distance disjoncteur - PAC - Cable section according to the distance between the circuit breaker and the heat pump		
			- 10 m	10 -15 m	+ 15 m
DC 35	Monophasé 230 V	16 Ampères	3G2.5 mm2	3G2.5 mm2	3G6 mm2
DC 55	Monophasé 230 V	16 Ampères	3G2.5 mm2	3G2.5 mm2	3G6 mm2
DC 75	Monophasé 230 V	20 Ampères	3G2.5 mm2	3G2.5 mm2	3G6 mm2
DC 95	Monophasé 230 V	25 Ampères	3G2.5 mm2	3G2.5 mm2	3G6 mm2
DC 115	Monophasé 230 V	25 Ampères	3G2.5 mm2	3G2.5 mm2	3G6 mm2

Raccordement électrique sur le bornier de la PAC

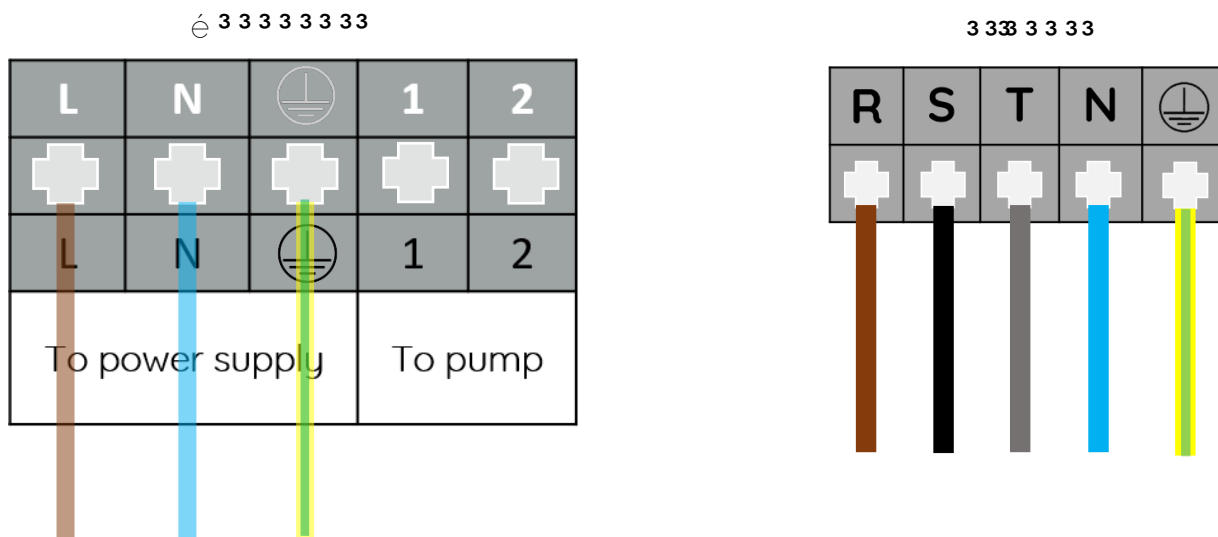

Dévisser la poignée pour accéder au branchement électrique



4. Mise en service

Après avoir correctement installer votre pompe à chaleur sur le circuit hydraulique de votre piscine ou de votre spa, la pompe de filtration de votre piscine doit être en fonctionnement afin que l'eau circule dans l'échangeur de votre pompe à chaleur.

- 1 :** Assurez-vous de régler correctement les vannes de votre pompe à chaleur : By Pass : ouvert à 50%, vanne d'entrée : ouverte à 100%, vanne de sortie ouverte à 70%
- 2 :** Mettre en marche votre pompe de filtration et vérifier l'absence de fuite sur le circuit hydraulique et la bonne circulation de l'eau au niveau des buses de refoulements de la piscine ou du spa.
- 3 :** Connecter l'alimentation électrique et appuyez ensuite sur la touche ON/OFF de la télécommande, si l'installation est correctement réalisée, la pompe à chaleur doit s'allumer immédiatement.
- 4 :** Après quelques minutes, l'air rejeté par le ventilateur doit être significativement plus froid que l'air ambiant.
- 5 :** Lorsque la pompe à chaleur fonctionne coupez la pompe de filtration l'unité doit alors s'arrêter.
- 6 :** Faites fonctionner 24/24h votre pompe de filtration et pompe à chaleur jusqu'à obtention de la température souhaitée. Lorsque la température souhaitée est atteinte l'unité va ralentir, lorsque la température sera maintenue pendant 45 minutes et ; l'unité va s'arrêter et redémarrera automatiquement dès que la température de l'eau sera inférieure de 0.2 °C à l'a température de consigne demandée (Attention : votre pompe de filtration doit être en marche pour que la pompe à chaleur puisse fonctionner).

5. Utilisation de la télécommande

5.1 Présentation générale

Votre pompe à chaleur est équipée avec une commande digitale tactile programmée par défaut en mode chaud à l'usine.

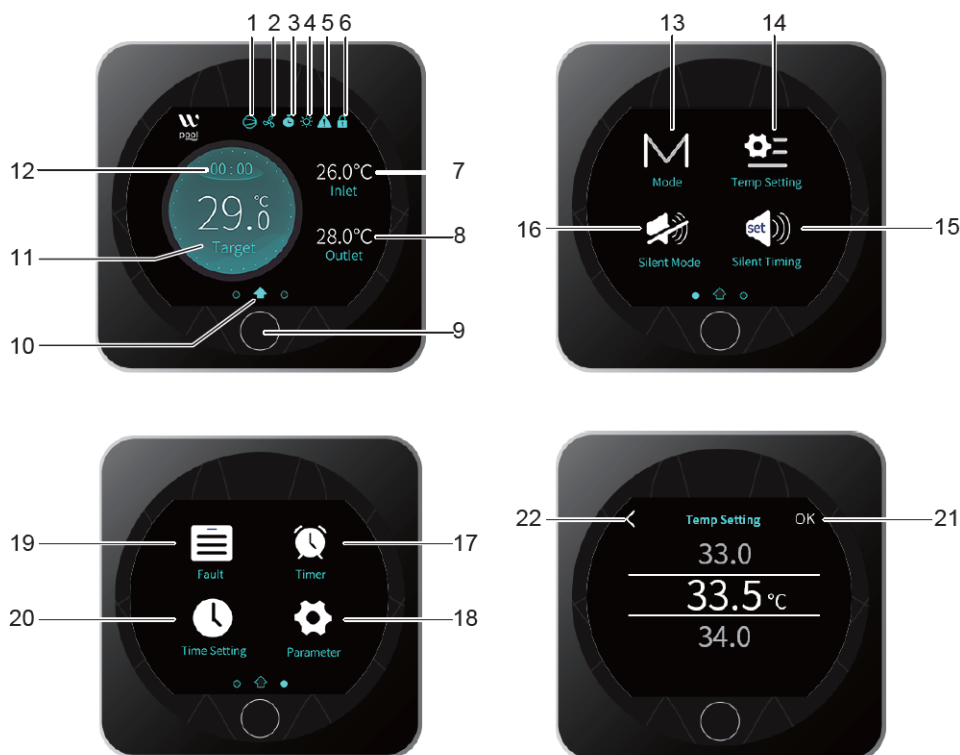

- 1 : Témoin de fonctionnement du compresseur
- 2 : Ventilation
- 3 : Minuteur
- 4 : Modes de réglage de la température : chaud – froid – auto
- 5 : Alarme
- 6 : Verrouillage de l'écran
- 7 : Température d'entrée d'eau
- 8 : Température de sortie d'eau
- 9 : On/Off/Retour
- 10 : Ecran principal
- 11 : Température de consigne
- 12 : Heure du système
- 13 : Mode en cours de fonctionnement
- 14 : Changement de température de consigne
- 15 : Paramètres du mode silence
- 16 : Activer le mode silence
- 17 : Programmation horaire
- 18 : Paramètres avancés
- 19 : Liste des codes erreurs

20 : Réglage de la date et de l'heure

21 : Confirmer

22 : Retour (ATTENTION les paramètres en cours de modification ne seront pas sauvegardés)



OFF :

Lorsque la pompe à chaleur est en veille, vous verrez apparaitre OFF sur l'écran. Après un certain temps l'écran s'éteint et se mets en veille.

ON :

Lorsque la pompe à chaleur est en fonctionnement, l'écran devient bleu.

Pour passer d'un mode à l'autre pressez le bouton central noir pendant 0.5 secondes.

5.2 Réglage de la date et de l'heure

La date et l'heure peuvent être paramétrées en mode ON ou OFF



Pressez une fois le bouton central pour retourner à l'écran principal.

5.3 Réglage de la programmation horaire

La programmation de cette fonction est obligatoire si vous souhaitez prévoir des plages de fonctionnement pour votre pompe à chaleur (ATTENTION : La pompe de filtration de votre piscine doit être en fonctionnement pour que votre pompe à chaleur démarre). Vous pouvez programmer une heure de départ et une heure d'arrêt de votre pompe à chaleur.



Coche Bleu : Activé
Coche Grise : Désactivé

Pressez deux fois le bouton central pour retourner à l'écran principal.



5.4 Réglage de la température de consigne

La température de consigne peut être changée en mode ON ou OFF avec une précision de 0.5°C.



Pressez une fois le bouton central pour revenir à l'écran principal

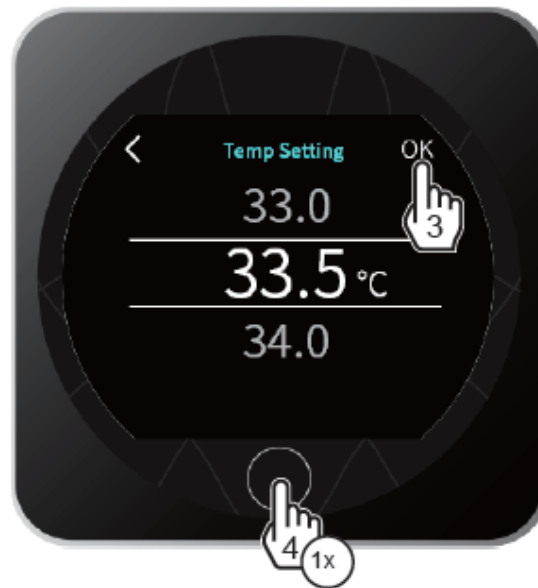

Pressez une fois le bouton central pour revenir à l'écran principal

5.5 Sélection du mode de température



Pressez une fois le bouton central pour revenir à l'écran principal

5.6 Sélection du mode de température

L'écran peut-être verrouiller ou déverrouiller en mode ON ou OFF



Pressez une fois le bouton central pour revenir à l'écran principal

5.7 Réglage du mode silence

Le mode Silence permet à la pompe à chaleur de fonctionner de manière très économique et silencieuse lorsque le besoin de chauffage est peu important (besoin uniquement de maintien de la température avec des conditions climatiques très favorables ou besoin spécifique d'un fonctionnement ultra silencieux)

Activation / Désactivation



Mode silence activé



Mode silence désactivé



Pressez une fois pour retourner à l'écran principal



Pressez deux fois le bouton central pour revenir à l'écran principal. Une fois le réglage activé il est actif 7j/7.

5.8 Codes pannes / erreurs

Attention certaines opérations doivent être réalisées par des techniciens agréés.

Si une erreur est détectée par la pompe à chaleur un petit triangle apparaît en haut de l'écran comme suit :



Lorsque le problème est résolu, l'erreur disparaît d'elle-même et le symbole d'erreur disparaît également.

Pour supprimer la liste d'erreur cliquez sur le symbole en forme de poubelle

Pressez 2 fois le bouton central pour retourner à l'écran principal

5.9 Liste de paramètres et codes erreur

Erreur / Panne	Code	Motif	Méthode de résolution
Défaut sonde de température d'entrée d'eau	P01	La sonde est endommagée ou en court circuit	Vérifiez ou changez la sonde
Défaut sonde de température de sortie d'eau	P02	La sonde est endommagée ou en court circuit	Vérifiez ou changez la sonde
Défaut sonde de température d'air ambiant	P04	La sonde est endommagée ou en court circuit	Vérifiez ou changez la sonde
Défaut sonde de température échangeur 1	P05	La sonde est endommagée ou en court circuit	Vérifiez ou changez la sonde
Défaut sonde de température échangeur 2	P15	La sonde est endommagée ou en court circuit	Vérifiez ou changez la sonde
Défaut sonde de température SUT	P07	La sonde est endommagée ou en court circuit	Vérifiez ou changez la sonde
Défaut sonde de température ET	P081	La sonde est endommagée ou en court circuit	Vérifiez ou changez la sonde
Défaut de la sonde ET (protection)	P 082	Surcharge du compresseur	Vérifiez si le système et le compresseur fonctionnent correctement
Défaut de la sonde de température antigel	P 09	La sonde est endommagée ou en court circuit	Vérifiez ou changez la sonde
Défaut de la sonde de pression	PP	La sonde est endommagée ou en court-circuit	Vérifiez ou changez la sonde
Haute pression du compresseur	E 01	Problème détecté au niveau de la pression du compresseur	Vérifiez le réglage des vannes (By Pass ouvert 70% - Vanne d'entrée d'eau ouverte 100% et vanne de sortie d'eau ouverte 70%). Vérifiez la sonde de pression et le détecteur de débit.
Basse pression du compresseur	E 02	Problème détecté au niveau de la pression du compresseur	Vérifiez et ou remplacez la sonde de pression et rapprochez-vous de votre installateur pour vérification du circuit frigorigène.
Détecteur de débit	E 03	Erreur détectée au niveau du détecteur de débit	Vérifiez la bonne circulation d'eau dans votre circuit hydraulique si la pompe de filtration n'est pas allumée votre pompe à chaleur ne fonctionnera pas. Vérifiez le réglage des vannes (By Pass ouvert 70% - Vanne d'entrée d'eau ouverte 100% et vanne de sortie d'eau ouverte 70%). Vérifiez et / ou remplacez le détecteur de débit

Protection température trop basse	E 05	La température ambiante ou de l'eau est trop basse	Vérifiez les températures d'eau et ambiante
Ecart entrée sortie d'eau	E 06	Le débit d'eau n'est pas suffisant	Vérifiez la circulation d'eau et le réglage des vannes (By Pass ouvert 70% - Vanne d'entrée d'eau ouverte 100% et vanne de sortie d'eau ouverte 70%).
Protection anti-gel	E 07	Le débit d'eau n'est pas suffisant	Vérifiez la circulation d'eau et le réglage des vannes (By Pass ouvert 70% - Vanne d'entrée d'eau ouverte 100% et vanne de sortie d'eau ouverte 70%).
Protection anti-gel principale	E 19	La température ambiante est trop basse	Vérifiez la sonde de température ambiante
Protection anti-gel secondaire	E 29	La température ambiante est trop basse	Vérifiez la sonde de température ambiante
Protection surcharge compresseur	E 051	Le compresseur est en surcharge	Vérifiez si le système et le compresseur fonctionne normalement
Défaut de communication	E 08	Défaut de communication entre la commande et la carte mère	Vérifiez la connexion entre la commande et la carte mère
Défaut de communication (module de contrôle de vitesse)	E 081	Module de contrôle de vitesse et commande en défaut de communication	Vérifiez la connexion
Température ambiante trop basse	TP	Température ambiante trop basse	Vérifiez la sonde de température ambiante
Défaut détecté au niveau de la ventilation	F 051	Un problème a été détecté au niveau du moteur de ventilateur	Vérifiez si le moteur de ventilateur est cassé ou bloqué.
Défaut moteur de ventilateur	F 031 F 032	Le moteur de ventilateur est bloqué, la connexion ne semble pas fonctionner normalement	Remplacez le moteur de ventilateur Vérifiez la connexion.

Attention certaines opérations doivent être réalisées par des techniciens agréés.

Si une erreur non listée ici est détectée merci de vous rapprocher de votre revendeur.

6 Schéma d'interface

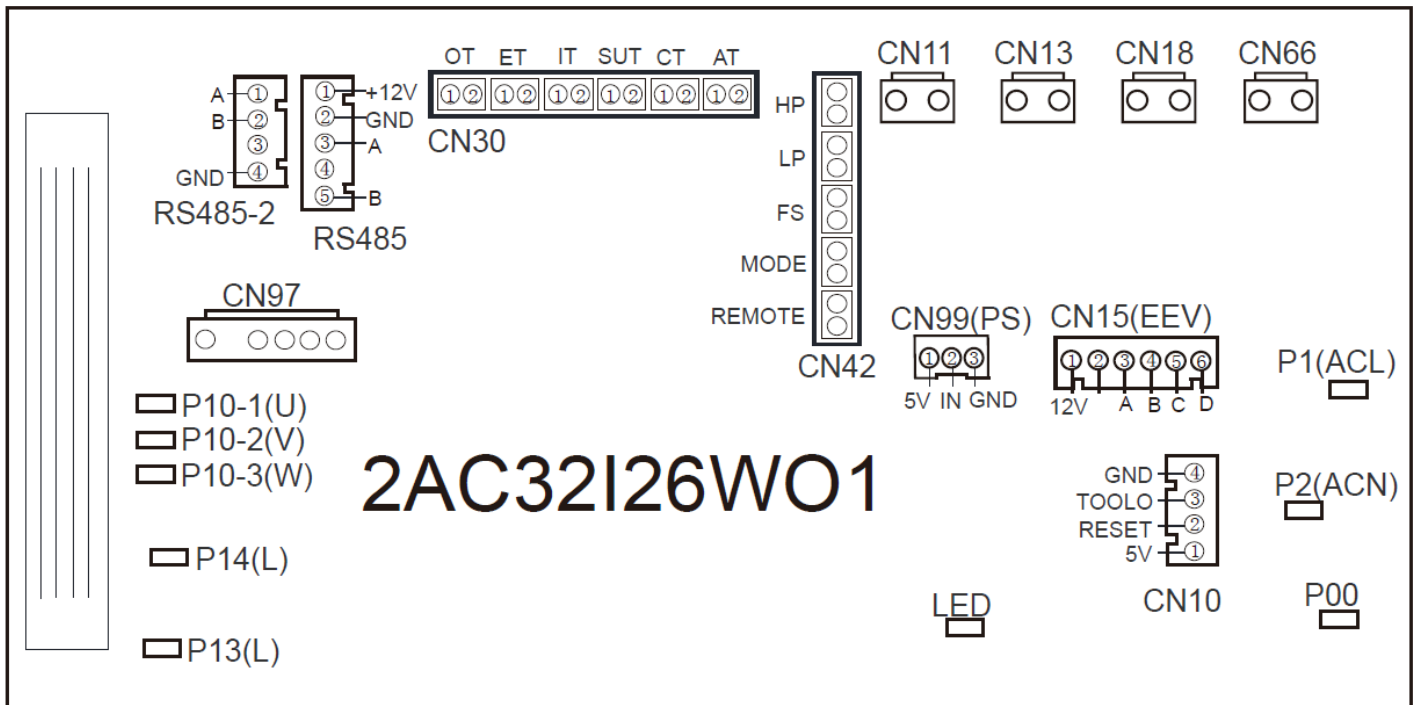
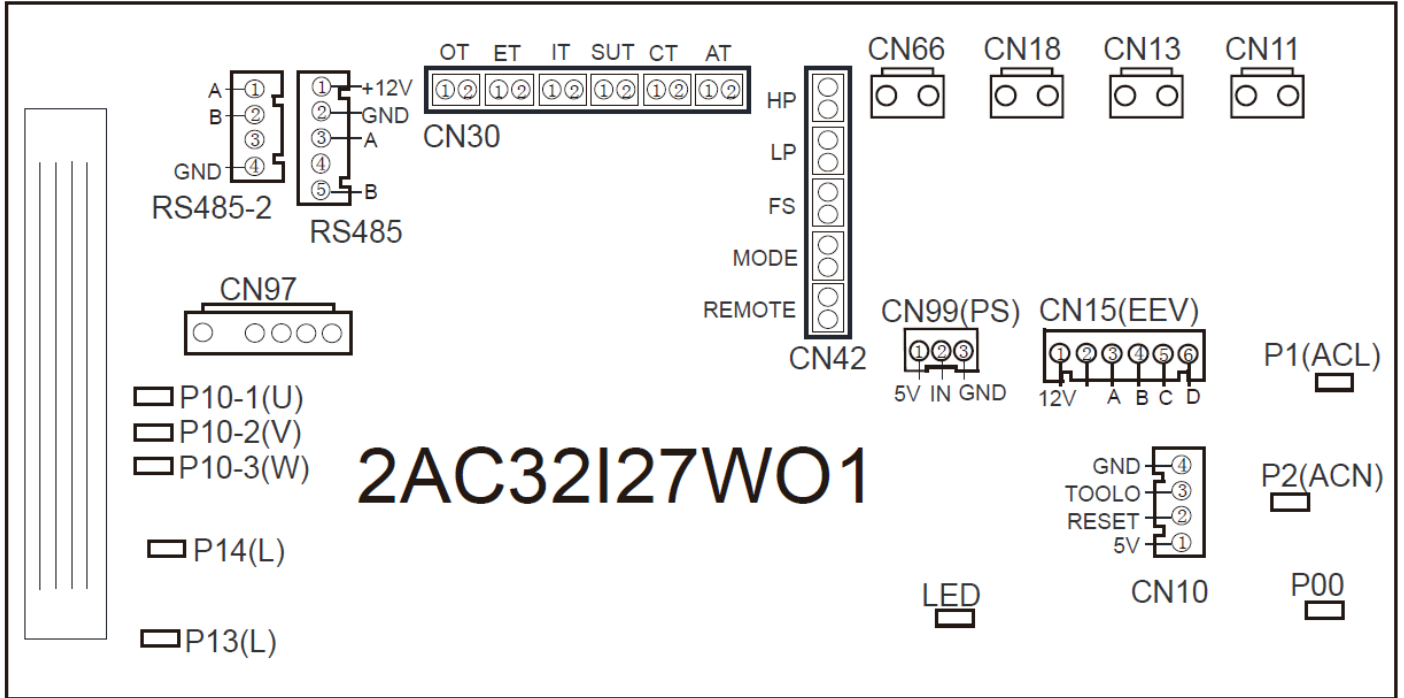

7 Schéma de la carte mère

Number	Sign	Meaning
01	P10-1/2/3(U/V/W)	Compressor
02	P13(L)	Resistance
03	P14(L)	Resistance
04	CN97	DC motor
05	RS485-2	The port for centralized control
06	RS485	Color line controller communication/WIFI
07	OT	Water output temperature
08	ET	System exhaust temperature
09	IT	Water input temperature
10	SUT	System suction temperature
11	CT	System fan coil temperature
12	AT	Ambient temperature
13	HP	System high pressure
14	LP	System low pressure
15	FS	Water flow switch
16	MODE	Mode switch
17	REMOTE	Emergency switch
18	CN66	Compressor signal
19	CN18	Water pump
20	CN13	Reserved
21	CN11	4-way value
22	CN99	Low pressure sensor
23	CN15	Electronic expansion valve
24	P1	Live wire
25	P2	Neutral wire
26	CN10	Program port

8 Manuel d'utilisateur du module WIFI



Téléchargez l'application Aquatemp



Paramètres techniques

TENSION DE FONCTIONNEMENT : CD8V-12V (valeur recommandée 12V) consommation max 1 A, courant de veille moyen 50mA

PLAGE DE TEMPERATURE : Température de marche : -30 ~ +70 ; Température de Conservation: -40 ~+85

INDICATEUR LUMINEUX LED : 4 voyants, Indicateur de configuration réseau, Indicateur de connexion routeur, Indicateur de connexion au serveur cloud, Indicateur de communication 485 ;

DIMENSION(LxLxH) : 78mmx63mmx24mm

A l'arrière du module WIFI, il y a un aimant, il peut être installé à l'intérieur ou à l'extérieur, à l'abri de la lumière directe du soleil ;

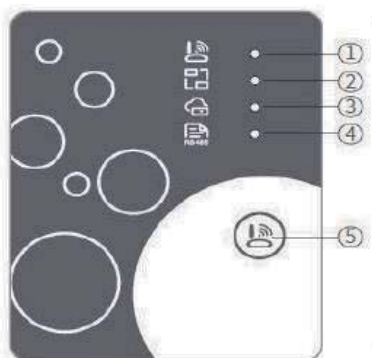

Voyant lumineux	Signification	Lumière longue	Lumière clignotante	Extinction
1	Indicateur de configuration du réseau	Configuration du réseau	Configuration de Smart Link	Terminé
2	Indicateur de connexion du routeur	Normal	Anormal	Arrêt / En cours de communication
3	Indicateur de connexion au serveur cloud	Normal	Anormal	Arrêt / En cours de communication
4	Indicateur de communication 485	Normal	Anormal	Arrêt / En cours de communication
5	Bouton configuration, mise en marche	----	----	Appuyez brièvement

Ouverture de session : Utilisez l'adresse e-mail et le mot de passe pour vous inscrire, vous connecter ou réinitialiser le mot de passe.

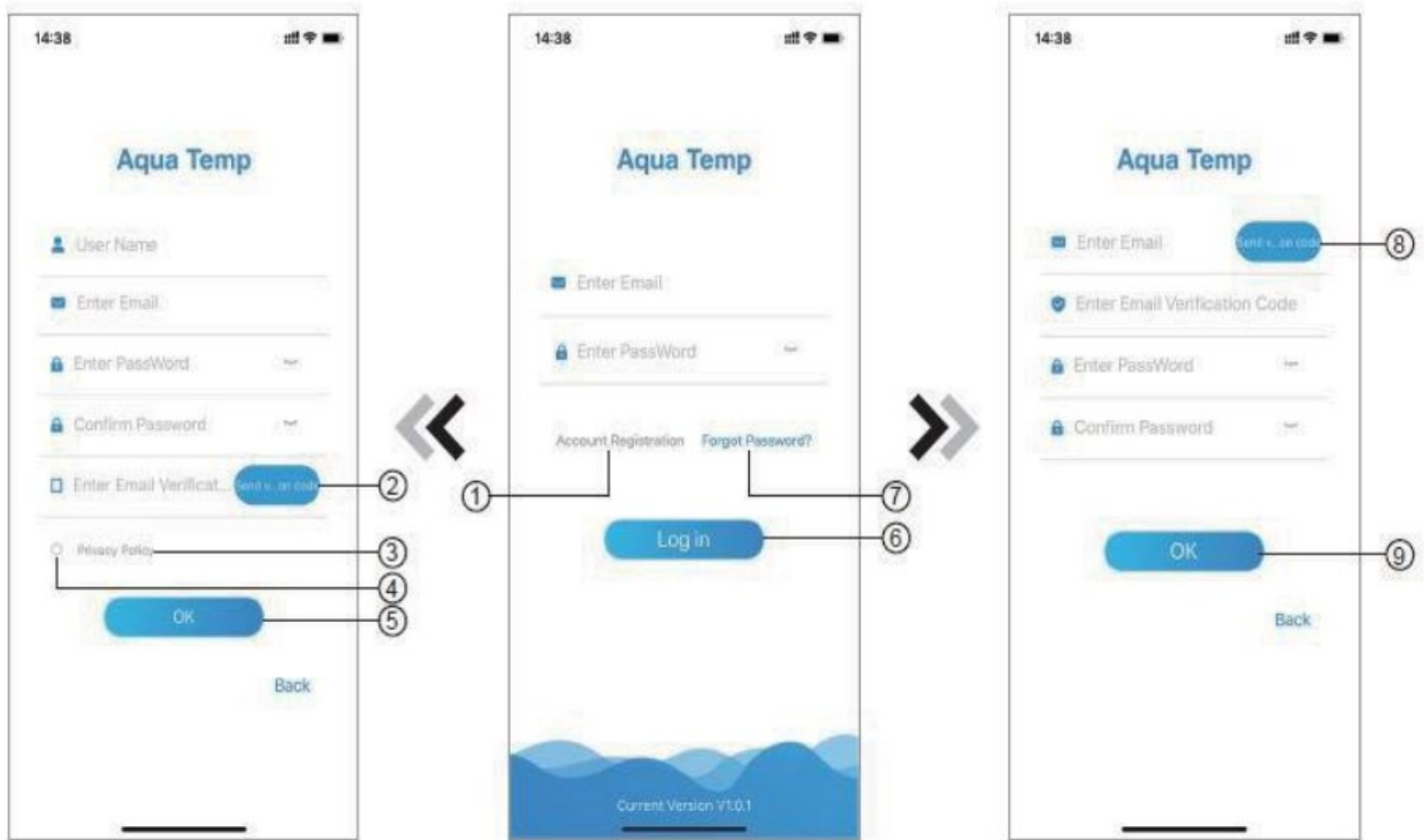

Enregistrement de compte : Pour enregistrer un compte, cliquez sur 1 (Fig.1) pour accéder à l'interface d'enregistrement de compte, remplissez les informations et cliquez sur 2 pour recevoir le code de vérification, tout en remplissant les informations demandées, cliquez sur 3 pour lire les détails de la politique de confidentialité, cliquez sur 4 pour accepter, et cliquez sur 5, l'enregistrement est terminé. Bien noter que la durée de validité d'un code de vérification est de 15min, veuillez remplir le code de vérification dans les 15min, sinon vous devrez en demander un nouveau.

Se connecter : Suivre les instructions de la page (Fig.1), entrer l'adresse e mail et le mot de passe enregistrés, cliquer et passer à la liste des appareils. Lorsque vous avez oublié votre mot de passe, cliquez sur mot de passe oublié et suivez les instructions.

Ajouter un appareil : Cliquez sur ajouter un nouvel appareil et suivez les instructions pour ajouter le WIFI ou le DTU.

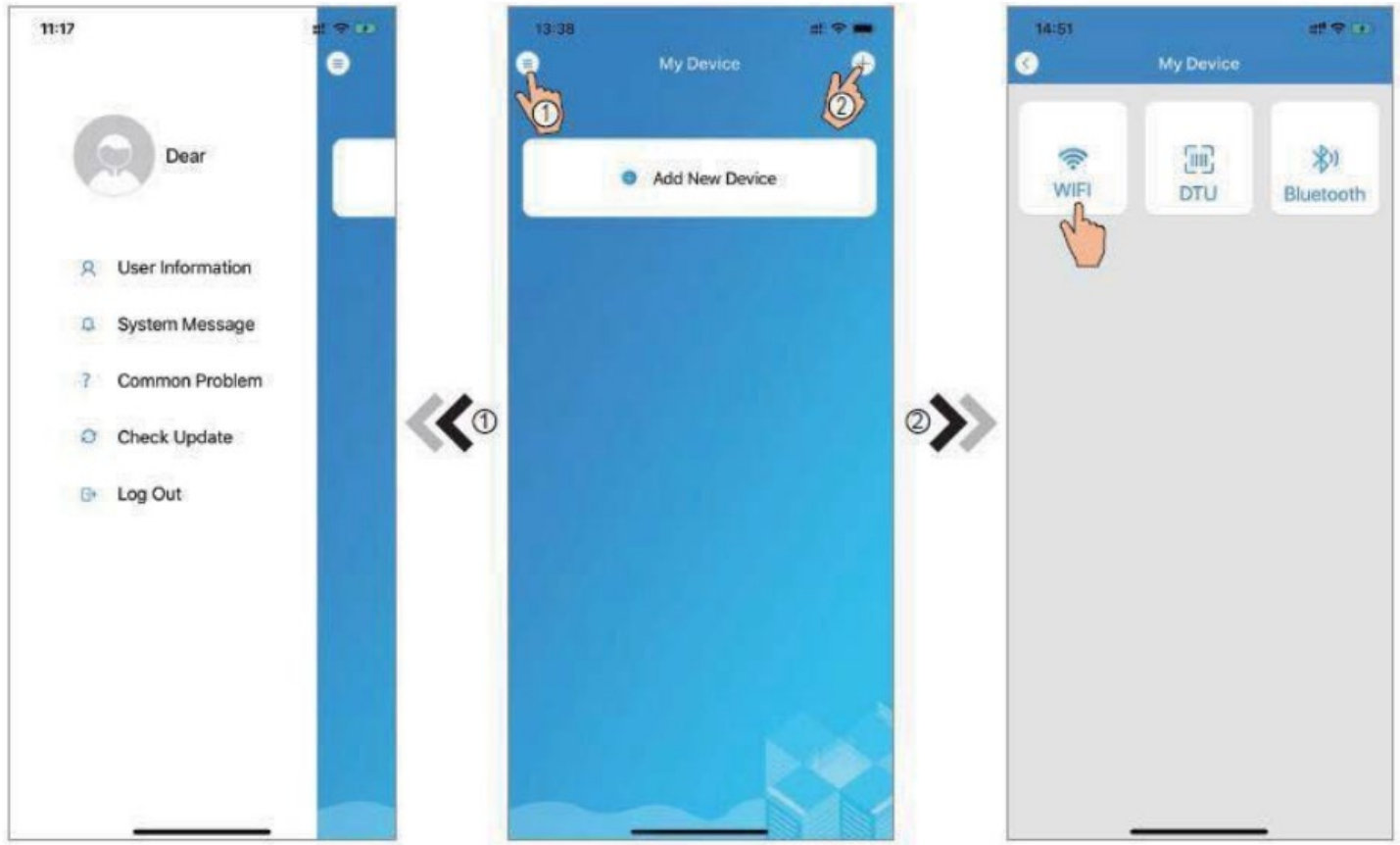

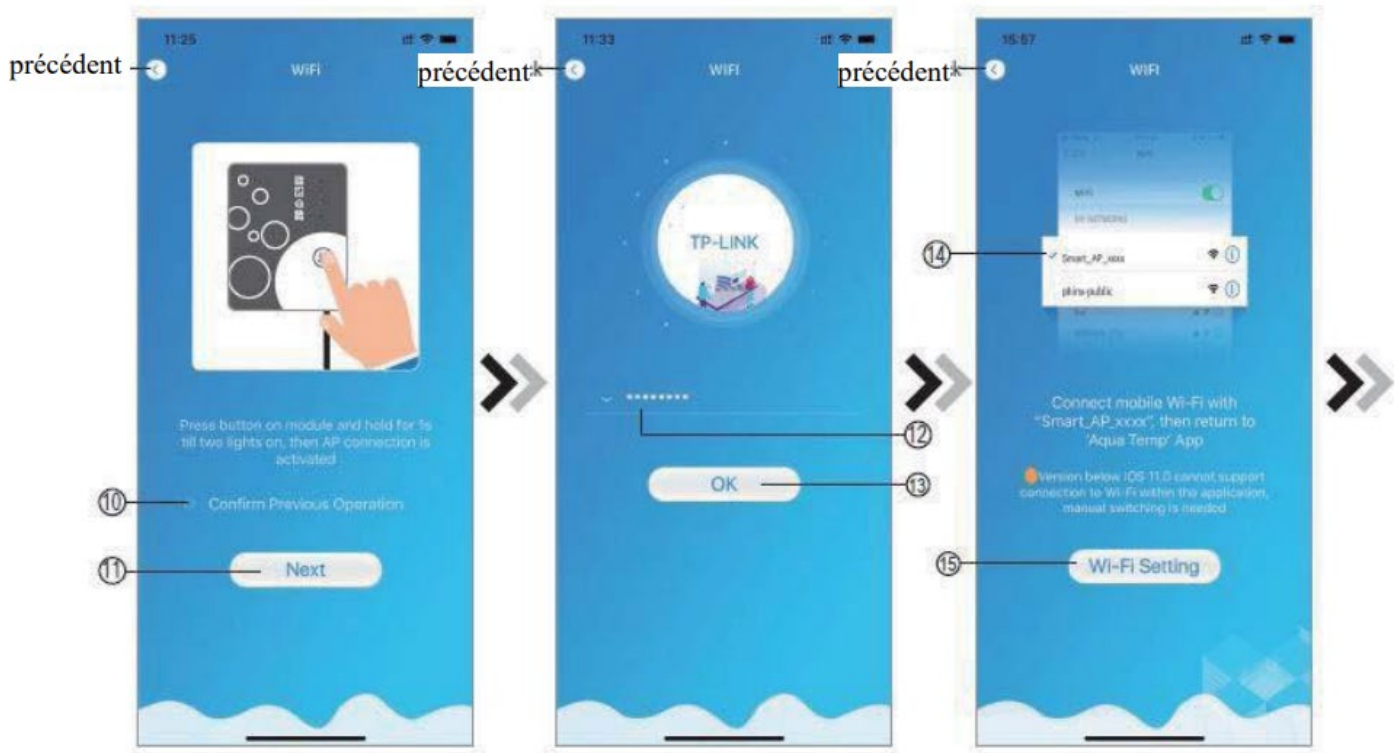

Configuration du WiFi :

Suivre les instructions présentes sur la page. Appuyer sur le bouton du module et le maintenir enfoncé pendant 1 seconde jusqu'à ce que deux lumières s'allument. Cliquer sur le 11 pour confirmer, saisir le mot de passe du WiFi pour établir la connexion puis cliquer sur confirmer. Se rendre dans paramètres du système et connecter le WiFi spécifié sélectionner le "Smart_ AP_ xxx" cliquer sur ok et suivre les instruction pour aller à l'interface de configuration WiFi.



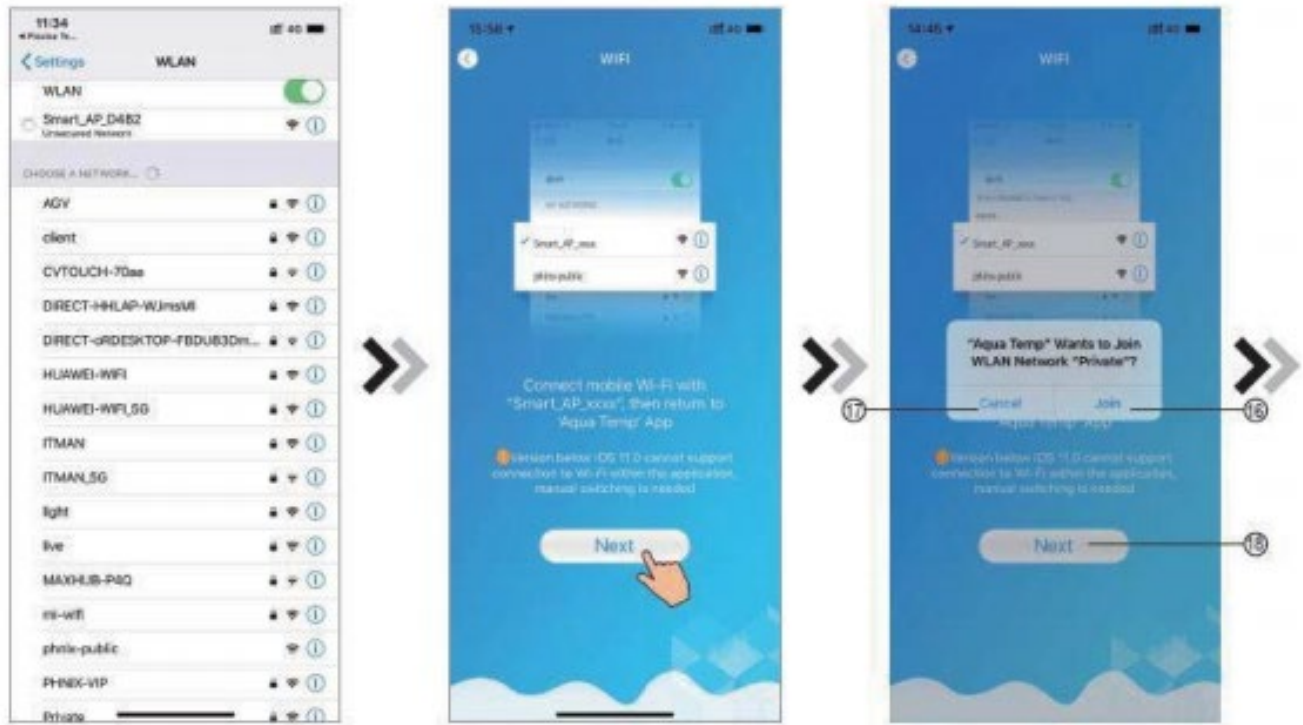







Gestion du Dispositif :

Une fois la connexion WiFi et DTU terminée, retourner à Mon Dispositif.
 Les opérations de gestion des périphériques sont les suivantes :





	Nom	Fonctions / Fonctions
	Activer/ Désactiver	Cliquez pour activer/ désactiver le dispositif/ Click to activate/deactivate the device
	Mode Silencieux	Cliquez pour activer le mode silencieux
	Décalage du Mode	Changement de mode : Chauffage, refroidissement ou Auto
	Réglages de chronomètre	Cliquez pour passer à l'interface activer/ désactiver et de coupure du son,du chronomètre
	Dépannage	Cliquez pour accéder à l'interface de dépannage
	Menu	Cliquez pour déplier ou réduire le menu

9 Garantie constructeur

La garantie constructeur est de 3 ans. A cette garantie pièces, s'ajoute une prise en charge main d'œuvre qui est comprise exclusivement en cas de retours dans nos ateliers. Si un retour de la pompe à chaleur est demandé par le fabricant, les coûts de transports pour le retour en atelier sont à la charge du client et le coup de retour chez le client sont à la charge du fabricant.

Cette garantie est exclusive et tient lieu de toute autre garantie implicite de valeur marchande ou d'adaptation à une utilisation particulière et de toute autre garantie expresse ou implicite. Les dédommagements prévus dans cette garantie sont exclusifs et ils constituent la seule obligation de la Sté Warmpac et toute autre affirmation faite par une personne quelconque sera sans conséquence.

10 Conseils de sécurité



Ne pas toucher au ventilateur lorsque celui-ci est en fonctionnement, cela pourrait vous blesser, L'appareil doit être mis à l'abri de tout contact éventuel avec des enfants,

Vérifier régulièrement l'alimentation et les câbles de connexion de votre pompe à chaleur. Si vous avez le moindre doute, prenez contact avec votre installateur,

En cas de SAV vous devez impérativement utiliser les pièces d'origine du constructeur.

L'environnement autour de la pompe à chaleur doit toujours être propre, correctement ventilé et dépourvu de tout éléments qui pourrait influencer de manière négative les performances de l'unité.

Purgez le système de toute eau du système hydraulique afin de limiter la prise en glace.

Ne pas placer l'unité près d'une source de chaleur et ou inflammable car l'unité contient un gaz frigorigère qui peut résulter dans une explosion si il est mit en contact avec une source de chaleur et ou inflammable. Ne pas fumer a proximité de l'unité.

Lorsque des composants électriques sont remplacés, ils doivent être adaptés à l'usage prévu et aux spécifications correctes. Les directives d'entretien et de service du fabricant doivent être respectées à tout moment. En cas de doute, consultez le service technique du fabricant pour obtenir de l'aide.

Les contrôles suivants doivent être appliqués aux installations utilisant des réfrigérants inflammables :

La taille de la charge est conforme à la taille de la pièce dans laquelle les pièces contenant le réfrigérant sont installées ;

Les machines et les sorties de ventilation fonctionnent correctement et ne sont pas obstruées ; Si un circuit frigorigère indirect est utilisé, le circuit secondaire doit être contrôlé pour vérifier la présence de réfrigérant ; Le marquage sur l'équipement doit rester visible et lisible. Les marquages et les signes qui sont illisibles doivent être corrigés ;

Les tuyaux ou composants frigorigères sont installés dans une position où ils ne risquent pas d'être exposés à une substance susceptible de corroder les composants contenant du fluide frigorigère, à moins que les composants ne soient construits en matériaux intrinsèquement résistants à la corrosion ou qu'ils soient convenablement protégés contre une telle corrosion.

Faites régulièrement contrôler votre pompe à chaleur par un installateur agréé.

Attention en fin de vie cet appareil et le gaz qu'il contient doivent être recyclés, merci de vous rapprocher de votre revendeur.



Installation and User Guide

DC 35 / DC 55 / DC 75 / DC 95 / DC 115



1, avenue de Londres, 13127 Vitrolles, FRANCE

Tel: + 33 4 28 70 69 99

info@warmpac.fr

www.wpool.fr

Sarl au capital de 62 500 Euros - N° TVA intracommunautaire : FR 08519634851 - SIRET:519 634 851 00017 - Code APE : 4



Warning



Before installation, check the condition of your heat pump upon receipt and make the usual reservations. If you have any doubts or problems, send an AR letter to your installer or contact the manufacturer within 48 hours. After this period, no claim can be accepted.

In order to offer our customers reliable and quality products, it has been manufactured according to strict manufacturing and production standards.

This manual contains all the information necessary for the installation, troubleshooting and maintenance of the unit. Please refer to this manual before servicing or operating this unit.

The installation and commissioning of your device must be carried out by qualified specialist personnel in accordance with the applicable safety standards. Please read these instructions carefully. We will not be held responsible for any injury or damage to the machine resulting from installation errors. Failure to follow these instructions will result in loss of warranty.



Only use original spare parts from the manufacturer, failure to do so will result in loss of warranty.

Your heat pump unit must only be used to heat a swimming pool. Its use is reserved for heating and maintaining the temperature of a pool in conditions predetermined by a thermal assessment to be carried out with a dealer before choosing the heat pump.

This heat pump respects the manufacturing and communication standards defined by the DTP10 of the FPP and NFPAC.

CAUTION:

Do not use any means or process to accelerate the defrosting or cleaning of your heat pump. Do not pierce or burn or place near a source of combustion. The refrigerant gas must not contain a strong odor.

This appliance is not intended for use by children or persons of reduced physical or mental ability without supervision as this may result in serious injury or death.

The manufacturer and distributor shall not be held responsible for any damage to property and/or personal injury caused by improper use/installation.

The installation must comply with local electrical standards and be properly grounded. The device must be disconnected from the mains before any intervention.

Directive 2002/96/EC (WEEE): The crossed-out wheeled garbage can symbol on the bottom of the device indicates that this product, at the end of its useful life, must be disposed of separately from household waste, taken to a recycling center for electrical and electronic equipment, or returned to the dealer when an equivalent device is purchased.

Directive 2002/95/EC (RoHs): This product complies with Directive 2002/95/EC (RoHs) on the restriction of the use of harmful substances in electrical and electronic equipment.

The installation of a circuit breaker is necessary to prevent the risk of fire and electric shock. If the power supply is damaged, please have it replaced by a professional in order to avoid personal injury and property damage.



1. Technical datas

Reference		DC35	DC55	DC75	DC95	DC115
Pool capacity	Maxi	35m ³	55m ³	75m ³	95m ³	115m ³
Heating consumption*	kW	1.4- 6.8	1.3- 7.93	1.75- 10.90	3.21-15.81	3.21- 17.05
Comsumption*	kW	0.14- 1.51	0.12- 1.37	0.16- 1.96	0.31- 3.03	0.32- 3.98
COP *		10.0 ~4.5	11.24-5.79	10.88- 5.56	10.3-5.22	10.01-4.82
* Test carried out at 27 °C air temperature, with the same difference in temperature and water flow obtained at 15 °C.						
Rated current	A	1.02-5.18	0.9-6.0	1.2-8.6	1.5-13.3	2.0-17.5
Heating consumption**	kW	1.1- 5.2	0.96 ~ 6.46	1.52- 8.21	2.3- 12.14	2.07- 15.20
Comsumption**	kW	0.21- 1.24	0.19- 1.32	0.25- 1.84	0.37- 2.80	0.38- 3.60
** : Test carried out at 15 °C air temperature, with a water inlet at 26 °C and a water outlet at 28 °C in order to define the water flow rate, the heating capacity and the consumption, according to FPP standards.						
Cold power consumption**	kW	2.2	3.72	4.3	6.2	7.69
Consumption***	kW	1.4	1.45	1.78	3.3	2.66
COP***		1.55	2.57	2.43	1.86	2.89
*** Test performed at 35 °C air temperature, with water inlet at 30 °C and water outlet at 29 °C.						
Body		ASA	ASA	ASA	ASA	ASA
Controller		Ecran Digital tactile - Digital Touch screen				
Gaz		R32	R32	R32	R32	R32
Exchanger		Titane Twisté - Twisted Titanium	Titane Twisté - Twisted Titanium	Titane Twisté - Twisted Titanium	Titane Twisté - Twisted Titanium	Titane Twisté - Twisted Titanium
Compressor		Rotatif Panasonic - Panasonic Rotary	Rotatif Panasonic - Panasonic Rotary	Rotatif Panasonic - Panasonic Rotary	Rotatif Mitsubishi - Mitsubishi Rotary	Rotatif Mitsubishi - Mitsubishi Rotary
Ventilation units		1	1	1	1	1
Ventilation rotation speed	T/mn	400-700	400-750	400-800	300-750	400-750
Mode		Warm/ Cold/ Auto	Warm/ Cold/ Auto	Warm/ Cold/ Auto	Warm/ Cold/ Auto	Warm/ Cold/ Auto
Operating range		-7°C-43°C	-7°C-43°C	-7°C-43°C	-7°C-43°C	-7°C-43°C
Noise (1m)	dB(A)	38-50	41-50	42-51	42-55	45-56

Power supply		Mono 220-240V/50HZ				
Regulator		Electronique - Electronic	Electronique - Electronic	Electronique - Electronic	Electronique - Electronic	Electronique - Electronic
Water flow	m ³ /H	2.5	2.7	3.5	5.2	5.6
Unit dimension	mm	1000/418/605	1000/418/605	1000/418/605	1046/453/767	1160/490/862
Package dimensions (l/L/h)	mm	1030/435/615	1030/435/615	1030/435/615	1130/480/780	1210/510/880
NW/GW	kg	43/54	47/58	51/62	66/79	74/88
Warranty		3 ans 3 years	3 ans - 3 years	3 ans - 3 years	3 ans - 3 years	3 ans - 3 years

2.Heat pump dimensions

DC 35 - DC 55 - DC 75

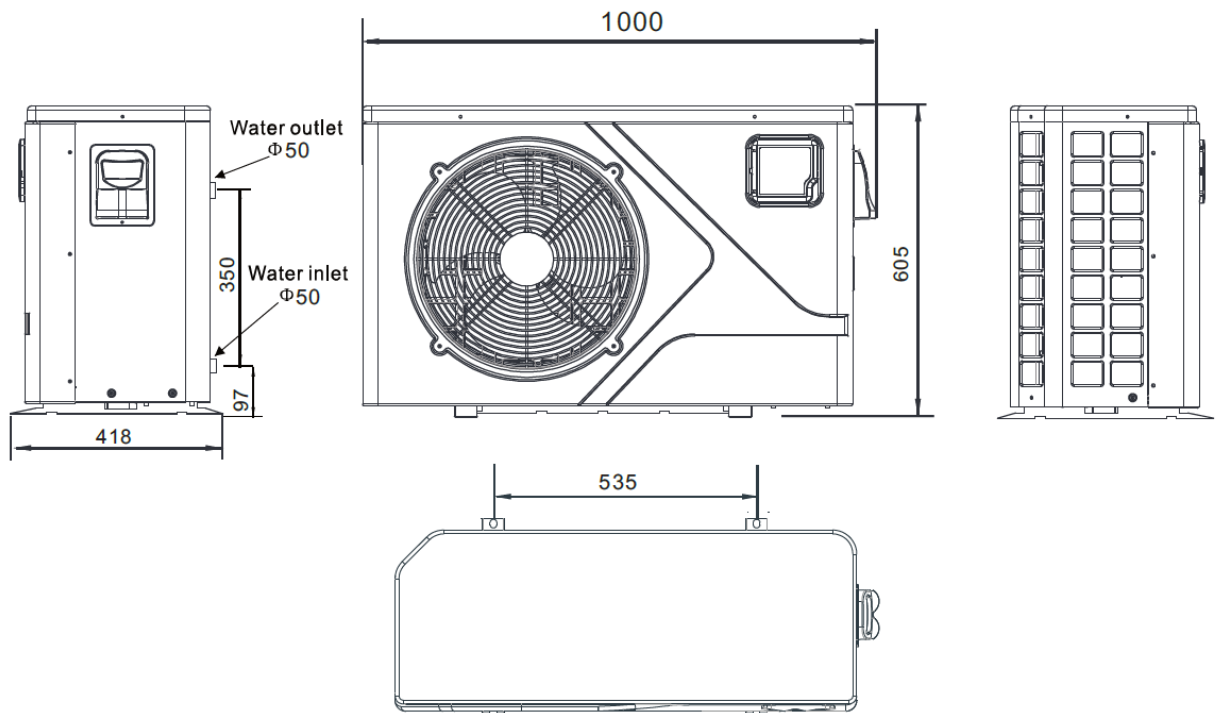

DC 95 :

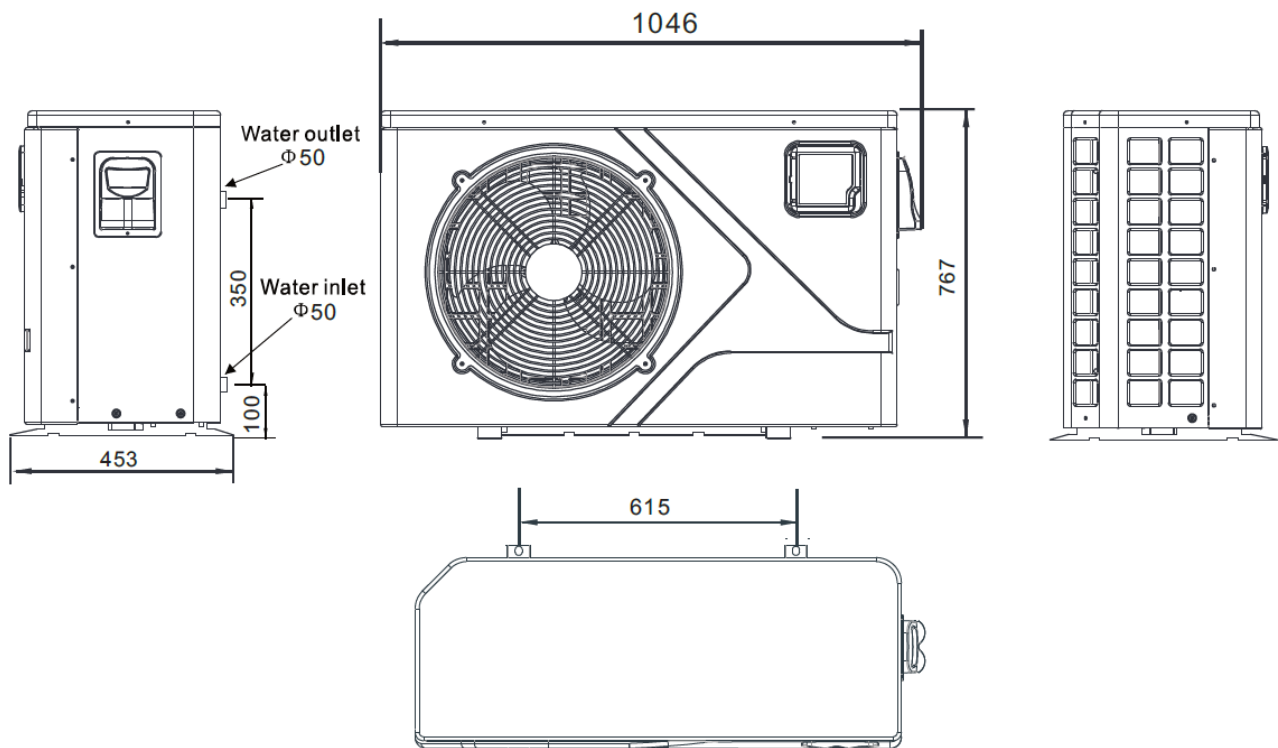

DC115

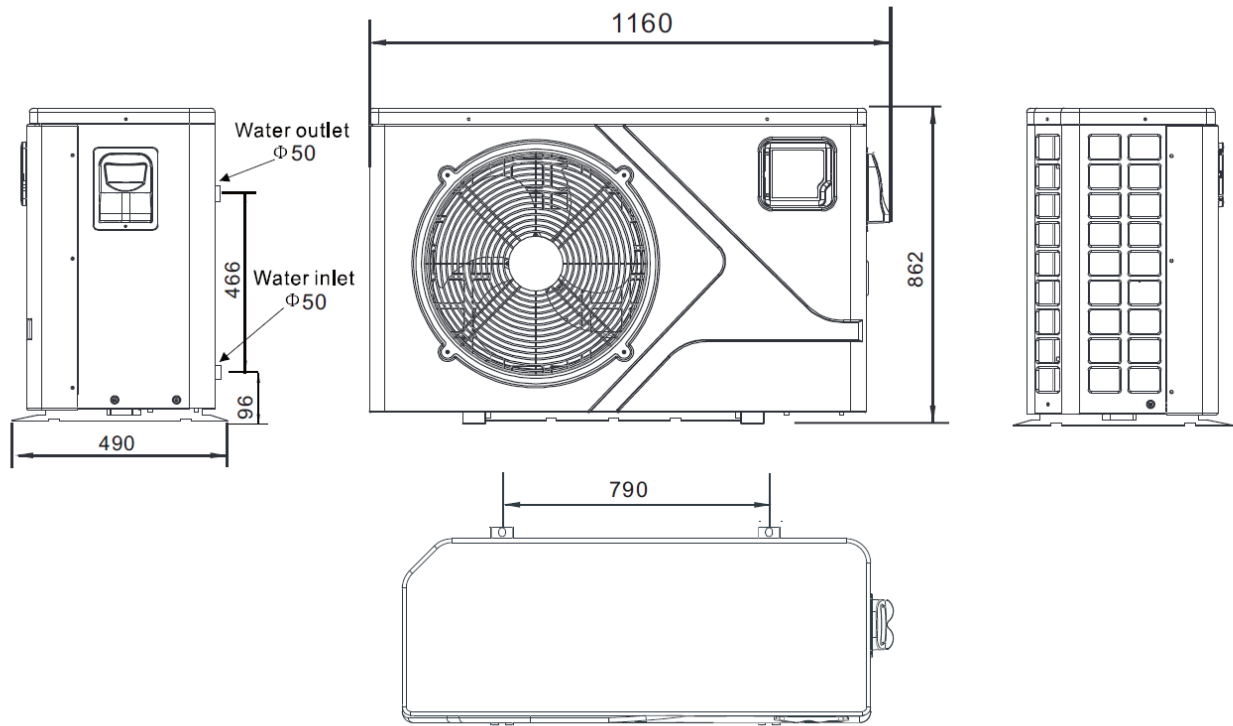

3. Installation and connections

When using the pool for the first time, make sure the pool is filled with water

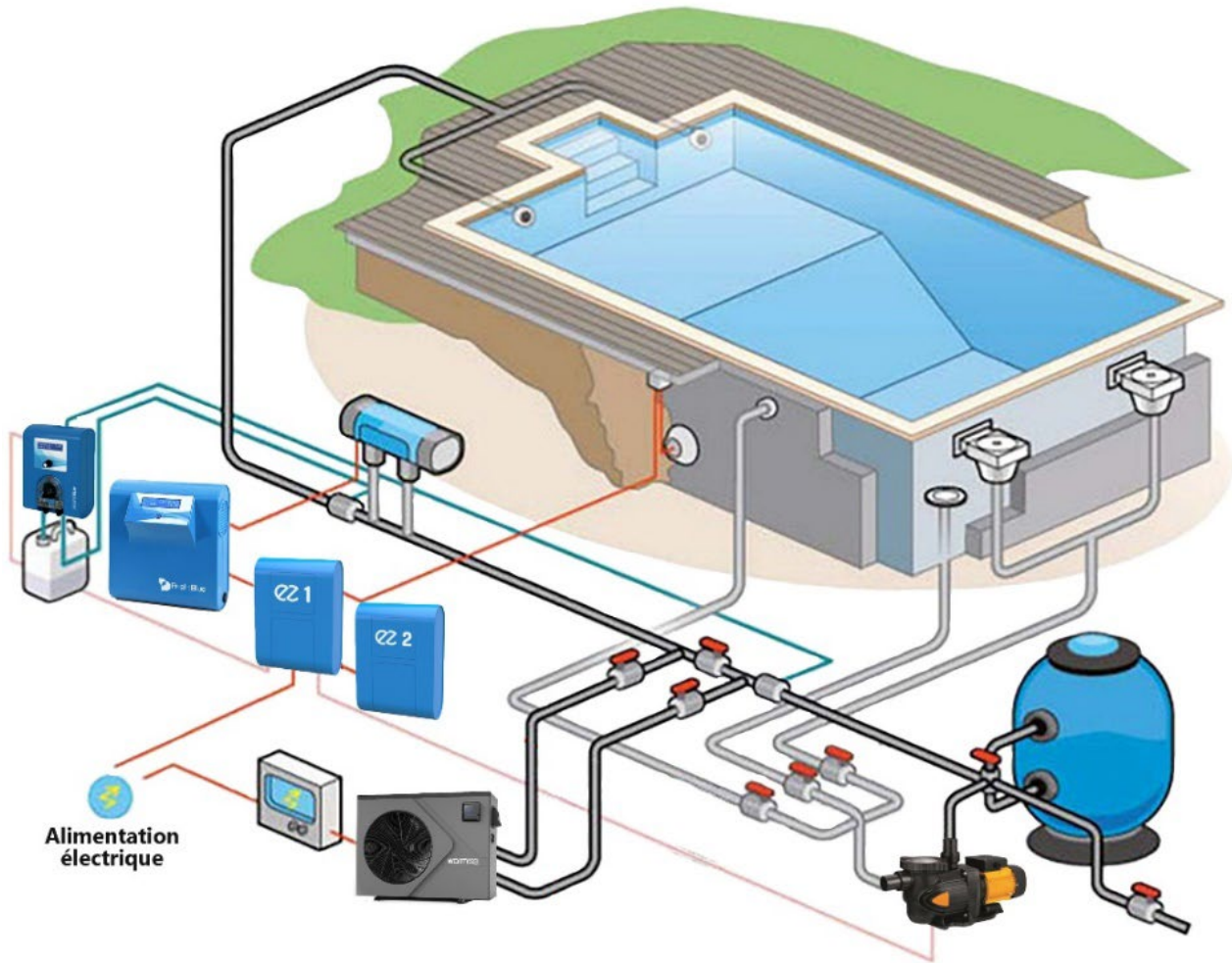



The choice of your heat pump must have been determined by a personalized heat balance in order to be certain that its characteristics will correspond to your needs. The company can in no way be held responsible for poor performance if its sizing has not been carried out thanks to a personalized heat balance and if the conditions of use indicated during the heat balance have not been respected.

Your heat pump must be placed outside and must respect the minimum distances of 3m without obstacle in front of the blower - 50cm from the wall for the back and 15cm above the ground.

We recommend that you use studs and that you drain your condensate on an all-weather surface (which can be covered with gravel).

If one of these recommendations is not applied or applicable, we ask you to contact the manufacturer to check whether the installation carried out or desired will not affect the proper functioning of your heat pump.

3.3 Hydraulic connection

The exclusive flow titanium heat exchanger of the pool heat pump does not require any special plumbing arrangements, except for the bypass. (Please set the flow rate according to the nameplate). The water pressure drop is less than 10kPa at the maximum flow rate. Since there is no residual heat or flame temperature, the unit does not require copper heat dissipation piping. PVC pipe can be installed directly on the unit.

Location: Connect the unit in the pool pump discharge (return) line, downstream of all filter and pool pumps, and upstream of all chlorinators, ozonators or chemical pumps. The standard model is equipped with slip-on fittings that accept 32mm or 50mm PVC pipe for connection to the pool or spa filtration piping.

Strongly consider adding a quick disconnect fitting to the inlet and outlet of the unit to allow easy draining of the unit for winterization and to provide easier access if maintenance is required.

Condensation: As the heat pump cools the air by approximately 4 to 5 degrees, water can condense on the evaporator fins. If the relative humidity is very high, this can amount to several liters per hour. The water will flow down the fins into the base pan and out through the barbed plastic condensate drain fitting located on the side of the base pan

This fitting is designed to accept a 20mm clear vinyl tube that can be pushed by hand and directed to an appropriate drain. It is easy to mistake condensation for water leakage inside the unit.

Note: A quick way to verify that the water is condensation is to turn off the unit and leave the pool pump running. If the water stops flowing out of the pool, it is condensation.

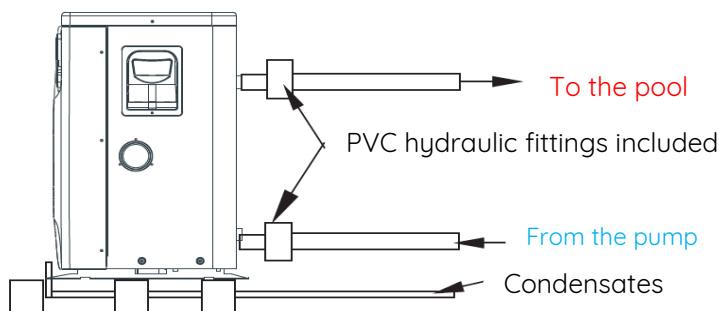

3.4 Electrical connection



Important : The connection of your heat pump must be carried out by authorised and qualified personnel. Check that the cable supplying the technical room has a sufficiently large cross-section to support the additional consumption required by the machine.

The heat pump must be supplied from an independent D-curve circuit breaker which can be either on the main electrical panel equipped with a differential or on an independent panel connected to the main panel, which will have a differential. If this is not the case, add a differential to the independent panel of your heat pump.

Référence	Power Supply	D-Curve circuit breaker power	Cable section according to the distance between the circuit breaker and the heat pump		
			- 10 m	10 -15 m	+ 15 m
DC 35	Monophasé 230 V	16 Ampères	3G2.5 mm ²	3G2.5 mm ²	3G6 mm ²
DC 55	Monophasé 230 V	16 Ampères	3G2.5 mm ²	3G2.5 mm ²	3G6 mm ²
DC 75	Monophasé 230 V	20 Ampères	3G2.5 mm ²	3G2.5 mm ²	3G6 mm ²
DC 95	Monophasé 230 V	25 Ampères	3G2.5 mm ²	3G2.5 mm ²	3G6 mm ²
DC 115	Monophasé 230 V	25 Ampères	3G2.5 mm ²	3G2.5 mm ²	3G6 mm ²

Electrical connection on the terminal block of the heat pump

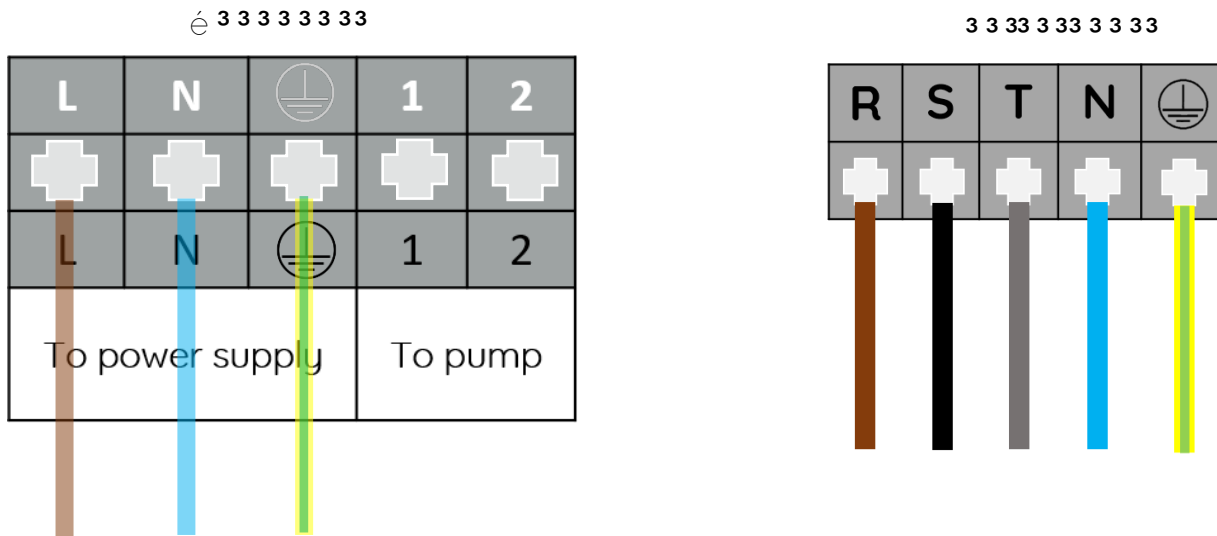

Unscrew the handle to access the electrical connection



4. Commissioning

After correctly installing your heat pump on the hydraulic circuit of your pool or spa, the filtration pump of your pool must be in operation in order for the water to circulate in the heat exchanger of your heat pump.

- 1: Make sure that the valves on your heat pump are set correctly: By Pass: open to 50%, inlet valve: open to 100%, outlet valve: open to 70%.
- 2: Turn on your filtration pump and check that there are no leaks in the hydraulic circuit and that the water is circulating properly through the pool or spa's discharge nozzles.
- 3: Connect the power supply and then press the ON/OFF button on the remote control. If the installation is correctly done, the heat pump should turn on immediately.
- 4: After a few minutes, the air released by the fan should be significantly cooler than the ambient air.
- 5: When the heat pump is running, turn off the filter pump and the unit should stop.
- 6: Run your filtration pump and heat pump 24 hours a day until the desired temperature is reached. When the desired temperature is reached the unit will slow down, when the temperature is maintained for 45 minutes and ; the unit will stop and restart automatically as soon as the water temperature is 0.2 °C lower than the set temperature requested (Attention : your filtration pump must be running for the heat pump to work).

5.Remote control guide

5.1 General presentation

Your heat pump is equipped with a digital touch control that is programmed by default in hot mode at the factory.

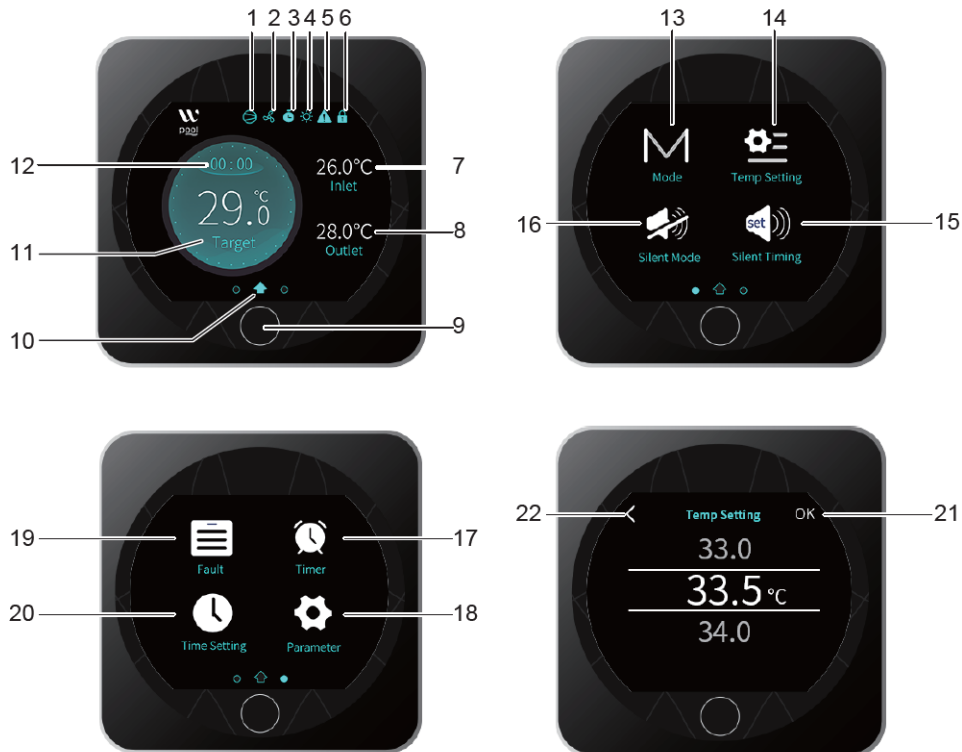

- 1: Compressor operation indicator
- 2: Ventilation
- 3 : Timer
- 4 : Temperature control modes : hot - cold - auto
- 5 : Alarm
- 6 : Display lock
- 7 : Water inlet temperature
- 8 : Water outlet temperature
- 9 : On/Off/Return
- 10 : Main screen
- 11: Setpoint temperature
- 12: System time
- 13: Operating mode
- 14: Setpoint temperature change
- 15: Silent mode settings
- 16: Activate Silent Mode
- 17: Time programming
- 18: Advanced parameters
- 19: Error code list

20 : Set the date and time

21 : Confirm

22 Back (WARNING the settings you are currently modifying will not be saved



OFF :

When the heat pump is in standby mode, you will see OFF on the display. After a while the display will turn off and go to standby.

ON :

When the heat pump is in operation, the display turns blue.

To switch from one mode to the other, press the black central button for 0.5 seconds.

5.2 Setting the date and time

Date and time can be set in ON or OFF mode



Press the center button once to return to the main screen.

5.3 Setting the time program

This function must be programmed if you wish to schedule operating times for your heat pump (CAUTION: Your pool's filtration pump must be operating for your heat pump to start). You can program a start time and a stop time for your heat pump.



Blue : Active
Grey : Inactive

Press the center button twice to return to the main screen.



5.4 Adjustment of the setpoint temperature

The setpoint temperature can be changed in ON or OFF mode with a precision of 0.5°C.



Press the center button once to return to the main screen

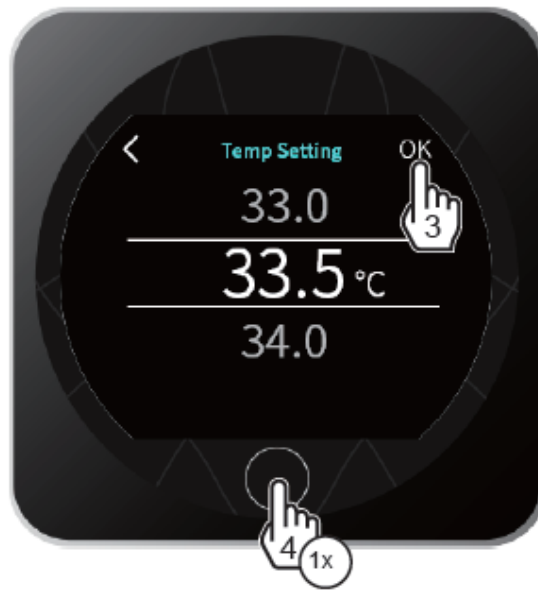

Press the center button once to return to the main screen

5.5 Temperature mode selection



Press the center button once to return to the main screen

5.6 Temperature mode selection

The screen can be locked or unlocked in ON or OFF mode



Press the center button once to return to the main screen

5.7 Setting the silent mode

The Silent mode allows the heat pump to operate very economically and quietly when the heating requirement is low (only need for temperature maintenance in very favourable weather conditions or specific need for ultra quiet operation)

Activation / Deactivation



Silence activated



Silence inactivated



Press once to return to the main screen



Press the central button twice to return to the main screen. Once the setting is activated it is active 7 days a week.

5.8 Troubleshooting / error codes

Please note that some operations must be performed by authorized technicians.

If an error is detected by the heat pump, a small triangle appears at the top of the screen as follows:



When the problem is solved, the error disappears by itself and the error symbol disappears as well.

To delete the error list click on the trash can symbol

Press the central button twice to return to the main screen

5.9 List of parameters and error codes

Error / Failure	Code	Motive	Method of resolution
Water inlet temperature sensor fault	P01	The probe is damaged or short-circuited	Check or change the probe
Water outlet temperature sensor fault	P02	The probe is damaged or short-circuited	Check or change the probe
Ambient temperature sensor fault	P04	The probe is damaged or short-circuited	Check or change the probe
Heat exchanger temperature sensor fault 1	P05	The probe is damaged or short-circuited	Check or change the probe
Défaut sonde de température échangeur 2	P15	The probe is damaged or short-circuited	Check or change the probe
Temperature sensor fault SUT	P07	The probe is damaged or short-circuited	Check or change the probe
ET temperature probe fault	P081	The probe is damaged or short-circuited	Check or change the probe
ET probe fault (protection)	P 082	Compressor overload	Check if the system and the compressor are working properly
Antifreeze temperature probe fault	P 09	The probe is damaged or short-circuited	Check or change the probe
Pressure sensor fault	PP	The probe is damaged or short-circuited	Check or change the probe
Compressor high pressure	E 01	Compressor pressure problem detected	Check the valve settings (By Pass open 70% - Water inlet valve open 100% and water outlet valve open 70%). Check the pressure sensor and the flow sensor.
Compressor low pressure	E 02	Problem detected at compressor pressure	Check and/or replace the pressure sensor and contact your installer to check the refrigerant circuit.
Water flow switch	E 03	Flow sensor error detected	Check the water circulation in your hydraulic circuit if the filtration pump is not turned on your heat pump will not work. Check the valve settings (By Pass open 70% - Water inlet valve open 100% and water outlet valve open 70%). Check and / or replace the flow sensor
Low temperature protection	E 05	Ambient or water temperature is too low	Check the water and ambient temperatures
Water inlet and outlet gap	E 06	The water flow is not sufficient	Check the water circulation and the valve settings (By Pass open 70% - Water inlet valve open 100% and

			water outlet valve open 70%).
Anti-frost protection	E 07	The water flow is not sufficient	Check the water circulation and the valve settings (By Pass open 70% - Water inlet valve open 100% and water outlet valve open 70%).
Primary frost protection	E 19	Ambient temperature is too low	Check the ambient temperature sensor
Secondary anti-freeze protection	E 29	Ambient temperature is too low	Check the ambient temperature sensor
Compressor overload protection	E 051	Compressor is overloaded	Check if the system and the compressor are working normally
Communication fault	E 08	Communication failure between control and motherboard	Check the connection between the control and the motherboard
Communication fault (speed control module)	E 081	Speed control module and control unit not communicating	Check the connection
Room temperature too low	TP	Ambient temperature too low	Check the room temperature sensor
Fault detected in the ventilation system	F 051	A problem has been detected in the fan motor	Check if the fan motor is broken or blocked.
Fan motor fault	F 031 F 032	The fan motor is blocked, the connection does not seem to work normally	Replace the fan motor Check the connection

Please note that some operations must be performed by authorized technicians.

If an error not listed here is detected, please contact your dealer.

6 Interface diagram

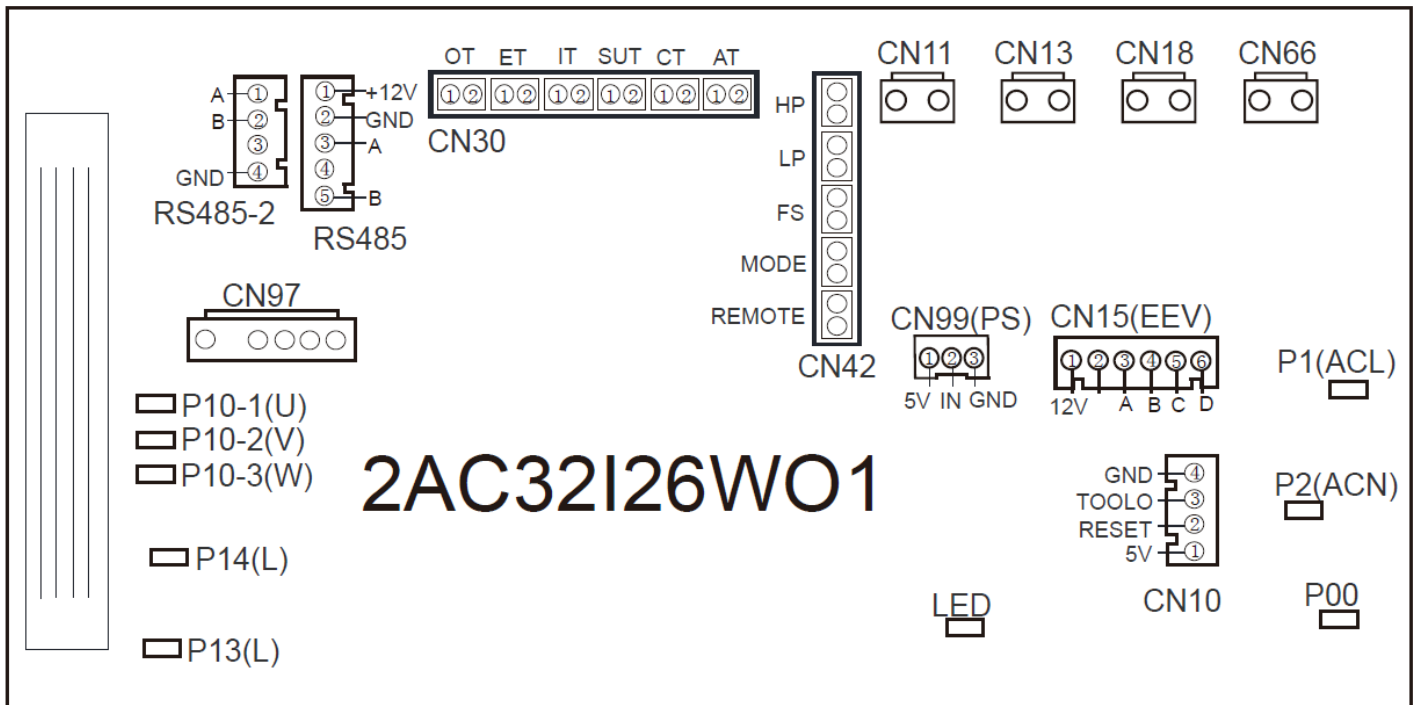
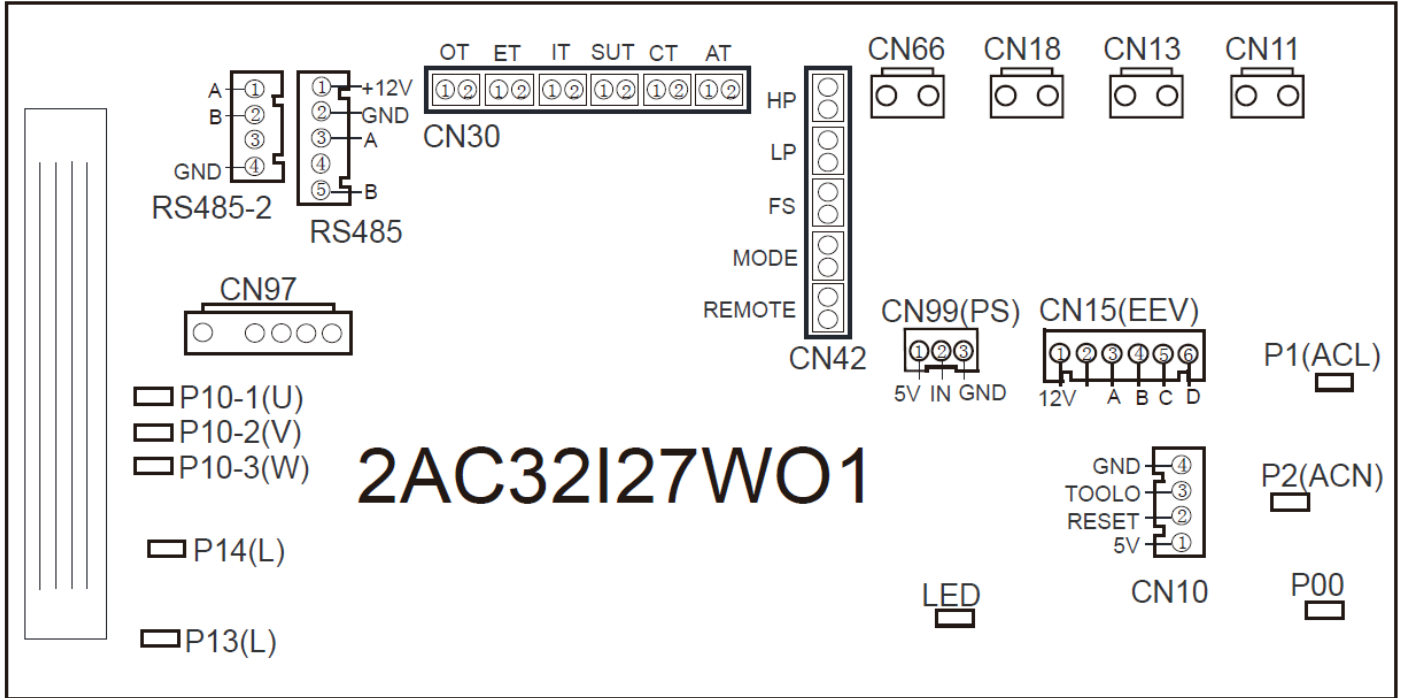

7 Mother board diagram

Number	Sign	Meaning
01	P10-1/2/3(U/V/W)	Compressor
02	P13(L)	Resistance
03	P14(L)	Resistance
04	CN97	DC motor
05	RS485-2	The port for centralized control
06	RS485	Color line controller communication/WIFI
07	OT	Water output temperature
08	ET	System exhaust temperature
09	IT	Water input temperature
10	SUT	System suction temperature
11	CT	System fan coil temperature
12	AT	Ambient temperature
13	HP	System high pressure
14	LP	System low pressure
15	FS	Water flow switch
16	MODE	Mode switch
17	REMOTE	Emergency switch
18	CN66	Compressor signal
19	CN18	Water pump
20	CN13	Reserved
21	CN11	4-way value
22	CN99	Low pressure sensor
23	CN15	Electronic expansion valve
24	P1	Live wire
25	P2	Neutral wire
26	CN10	Program port

8 WIFI module user manual



Download the Aquatemp application



Technical parameters

OPERATING VOLTAGE: CD8V-12V (recommended value 12V) max consumption 1 A, average standby current 50mA

TEMPERATURE RANGE: Operating temperature: -30 ~ +70; Storage temperature: -40 ~+85

LED INDICATOR : 4 lights, Network configuration indicator, Router connection indicator, Cloud server connection indicator, 485 communication indicator;

DIMENSION(L×L×H) 78mm×63mm×24mm

On the back of the WIFI module, there is a magnet, it can be installed indoors or outdoors, protected from direct sunlight;

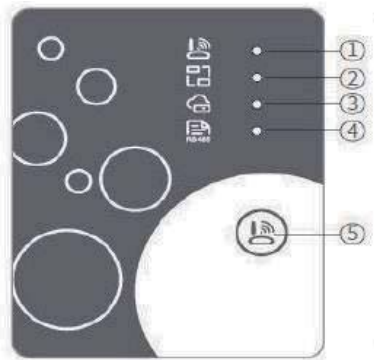

Light	Signification	Long light	Flashing light	Off
1	Network configuration indicator	Network setting	Smart Link setting	Finished
2	Router connection indicator	Normal	Abnormal	Off / In progress
3	Cloud server connection indicator	Normal	Abnormal	Off / In progress
4	485 communication indicator	Normal	Abnormal	Off / In progress
5	Configuration button, power on	----	----	Press briefly

Login: Use the email address and password to register, login or reset the password.

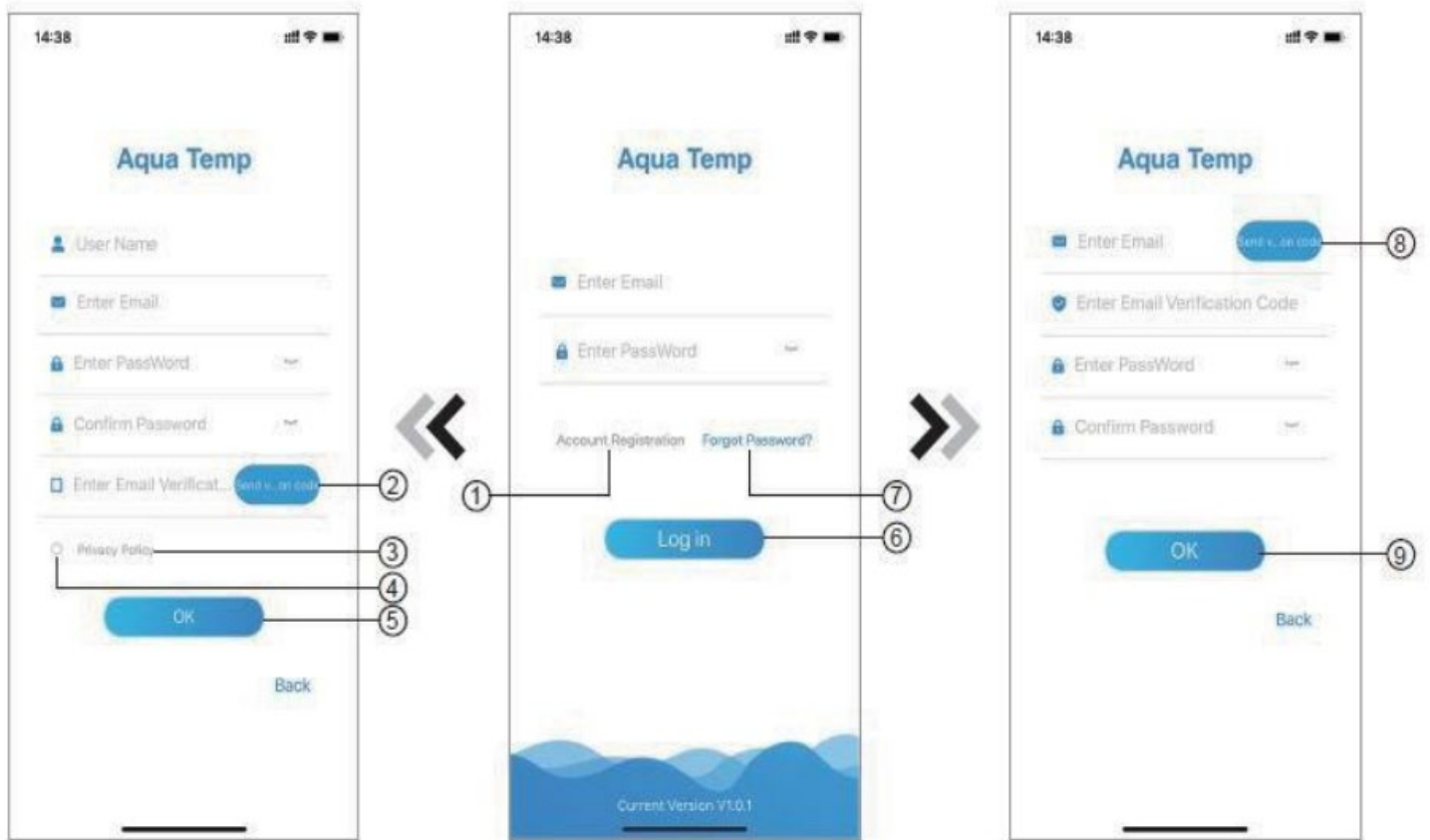

Account registration: To register an account, click 1 (Fig.1) to enter the account registration interface, fill in the information and click 2 to receive the verification code, while filling in the requested information, click 3 to read the privacy policy details, click 4 to accept, and click 5, the registration is complete. Please note that the validity of a verification code is 15min, please fill in the verification code within 15min, otherwise you will have to request a new one.

Login: Follow the instructions on the page (Fig.1), enter the registered email address and password, click and go to the device list. When you have forgotten your password, click on forgotten password and follow the instructions.

Add a device: Click on add a new device and follow the instructions to add the WIFI or DTU.

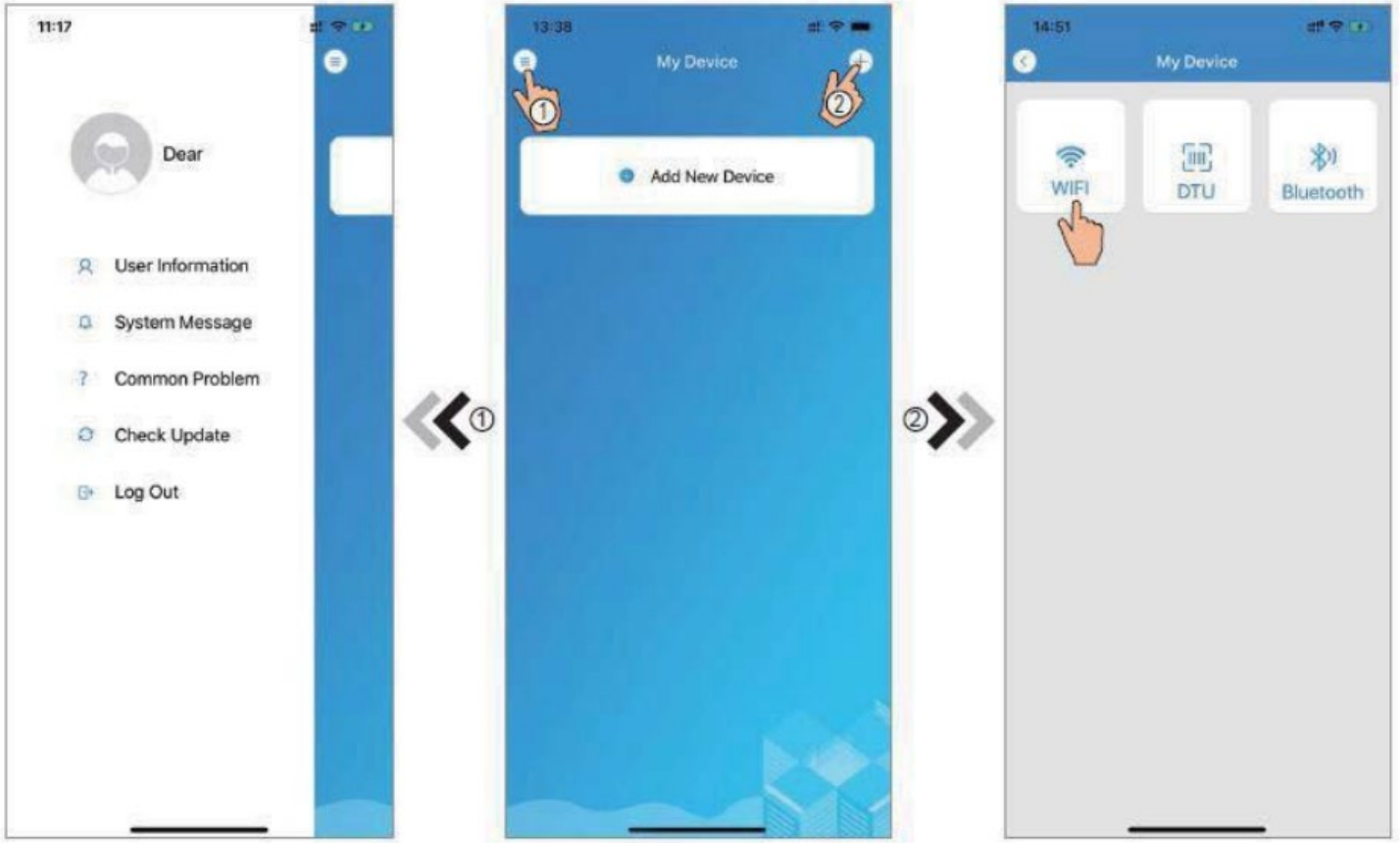

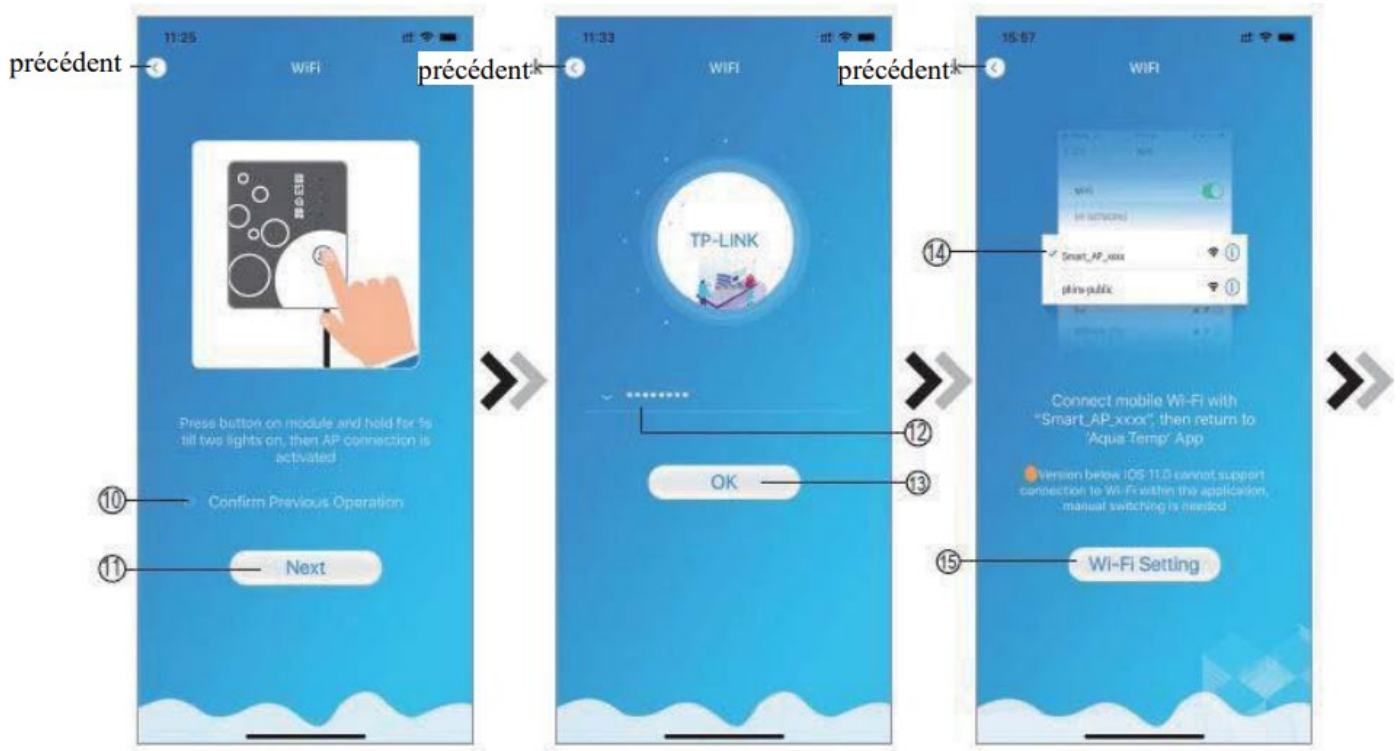

WFi setting :

Follow the instructions on the page. Press and hold the button on the module for 1 second until two lights come on. Click on 11 to confirm, enter the WFi password to establish the connection and click on confirm. Go to system settings and connect the specified WFi, select "Smart_ AP_ xxx", click ok and follow the instructions to go to the WFi configuration interface.



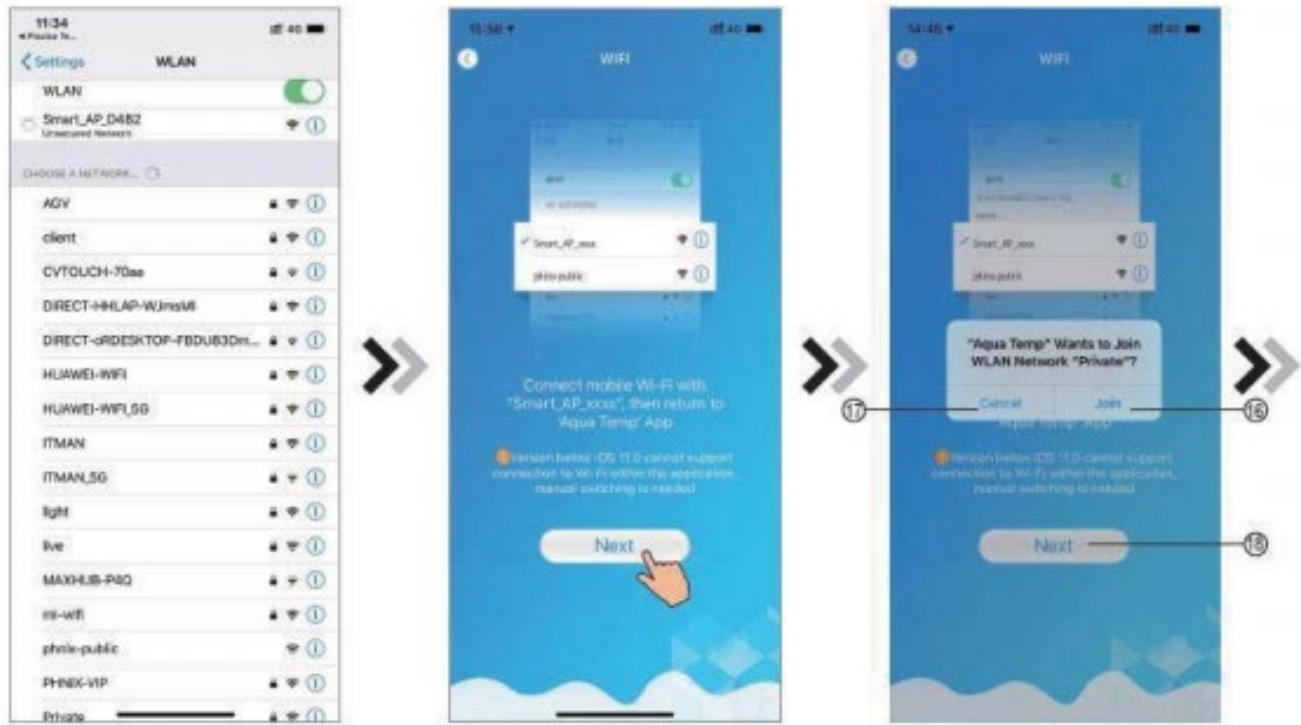





Device Management: Once the WFI and DTU connection is complete, return to My Device.

The device management operations are as follows:





	Name	Functions
	Activate/ Désactiver	Click to activate/deactivate the device
	Silence mode	Click here to activate silence mode
	Mode	Change mode: Heat, Cool or Auto
	Timer settings	Click to go to the interface to activate/deactivate and mute the sound and the timer
	Troubleshooting	Click to access the troubleshooting interface
	Menu	Click to expand or collapse the menu

9 Manufacturer's warranty

The manufacturer's warranty is 3 years. In addition to this parts warranty, we also provide a labor warranty, which is only included in the case of returns to our workshops. If a return of the heat pump is requested by the manufacturer, the transport costs for the return to the workshop are at the customer's expense and the cost of the return to the customer's premises are at the manufacturer's expense.

This warranty is exclusive and in lieu of any other implied warranty of merchantability or fitness for a particular purpose and of any other express or implied warranty. The remedies provided in this warranty are exclusive and constitute the sole obligation of Warmpac and any other representation made by any person shall be of no consequence.

10 Safety advice



Do not touch the fan while it is running, as this could cause injury. The unit should be kept away from children,

Regularly check the power supply and the connection cables of your heat pump. If you have any doubts, contact your installer,

In the event of a service call, you must use the manufacturer's original parts.

The environment around the heat pump must always be clean, properly ventilated and free of any elements that could negatively influence the performance of the unit.

Drain all water from the hydraulic system to limit freezing.

Do not place the unit near a source of heat or flammable materials as the unit contains a refrigerant gas that can result in an explosion if brought into contact with a source of heat or flammable materials. Do not smoke near the unit.

When electrical components are replaced, they must be suitable for the intended use and to the correct specifications. The manufacturer's maintenance and service instructions must be followed at all times. If in doubt, consult the manufacturer's technical service department for assistance.

The following controls should be applied to installations using flammable refrigerants:

Charge size is consistent with the size of the room in which the refrigerant-containing parts are installed;

Machinery and ventilation outlets are functioning properly and are not obstructed; If an indirect refrigerant circuit is used, the secondary circuit must be checked for the presence of refrigerant; Markings on equipment must remain visible and legible. Markings and signs that are illegible must be corrected;

Refrigerant pipes or components are installed in a position where they are not likely to be exposed to any substance that could corrode the refrigerant-containing components, unless the components are constructed of inherently corrosion-resistant materials or are adequately protected against such corrosion.

Have your heat pump inspected regularly by an authorized installer.

At the end of its service life, this appliance and the gas it contains must be recycled, please contact your dealer.



Guía de instalación y uso

DC 35 / DC 55 / DC 75 / DC 95 / DC 115



1, avenue de Londres, 13127 Vitrolles, FRANCE

Tel : + 33 4 28 70 69 99

info@warmpac.fr

www.wpool.fr

Sarl au capital de 62 500 Euros - N° TVA intracommunautaire : FR 08519634851 - SIRET:519 634 851 00017 - Code APE : 4



Advertencia



Antes de la instalación, compruebe el estado de su bomba de calor al recibirla y haga las reservas habituales. Si tiene alguna duda o problema, envíe una carta AR a su instalador o póngase en contacto con el fabricante en un plazo de 48 horas. Pasado este plazo, no se aceptará ninguna reclamación.

Para ofrecer a nuestros clientes productos fiables y de calidad, se ha fabricado siguiendo estrictas normas de fabricación y producción.

Este manual contiene toda la información necesaria para la instalación, la resolución de problemas y el mantenimiento de la unidad. Por favor, consulte este manual antes de reparar o hacer funcionar esta unidad.

La instalación y la puesta en marcha de su aparato deben ser realizadas por personal especializado y cualificado de acuerdo con las normas de seguridad vigentes. Lea atentamente estas instrucciones. No nos hacemos responsables de las lesiones o daños en la máquina derivados de errores de instalación. El incumplimiento de estas instrucciones supondrá la pérdida de la garantía.

Utilice únicamente piezas de recambio originales del fabricante, de lo contrario perderá la garantía.

Su unidad de bomba de calor sólo debe utilizarse para calentar una piscina. Su uso está reservado para calentar y mantener la temperatura de una piscina en condiciones predeterminadas por una evaluación térmica que debe realizarse con un distribuidor antes de elegir la bomba de calor.



Esta bomba de calor respeta las normas de fabricación y comunicación definidas por la DTP10 de la FPP y la NFPAC.

PRECAUCIÓN:

No utilice ningún medio o proceso para acelerar la descongelación o la limpieza de su bomba de calor. No perforar ni quemar ni colocar cerca de una fuente de combustión. El gas refrigerante no debe contener un olor fuerte.

Este aparato no está destinado a ser utilizado por niños o personas con capacidad física o mental reducida sin supervisión, ya que puede provocar lesiones graves o la muerte.

El fabricante y el distribuidor no se hacen responsables de los daños materiales y/o personales causados por un uso/instalación inadecuado.

La instalación debe cumplir con las normas eléctricas locales y estar debidamente conectada a tierra. El aparato debe estar desconectado de la red eléctrica antes de cualquier intervención.

Directiva 2002/96/CE (WEEE): El símbolo del cubo de basura con ruedas tachado en la parte inferior del aparato indica que este producto, al final de su vida útil, debe eliminarse por separado de los residuos domésticos, llevarse a un centro de reciclaje de aparatos eléctricos y electrónicos, o devolverse al distribuidor cuando se adquiera un aparato equivalente.

Directiva 2002/95/CE (RoHS): Este producto cumple con la Directiva 2002/95/CE (RoHS) sobre restricciones a la utilización de sustancias nocivas en aparatos eléctricos y electrónicos.

La instalación de un disyuntor es necesaria para evitar el riesgo de incendio y descarga eléctrica. Si la fuente de alimentación está dañada, haga que la sustituya un profesional para evitar daños personales y materiales.



1. Datos técnicos

Reference		DC35	DC55	DC75	DC95	DC115
Pool capacity	Maxi	35m ³	55m ³	75m ³	95m ³	115m ³
Heating consumption*	kW	1.4- 6.8	1.3- 7.93	1.75- 10.90	3.21-15.81	3.21- 17.05
Comsumption*	kW	0.14- 1.51	0.12- 1.37	0.16- 1.96	0.31- 3.03	0.32- 3.98
COP *		10.0 ~4.5	11.24-5.79	10.88- 5.56	10.3-5.22	10.01-4.82
* Test carried out at 27 °C air temperature, with the same difference in temperature and water flow obtained at 15 °C.						
Rated current	A	1.02-5.18	0.9-6.0	1.2-8.6	1.5-13.3	2.0-17.5
Heating consumption**	kW	1.1- 5.2	0.96 ~ 6.46	1.52- 8.21	2.3- 12.14	2.07- 15.20
Comsumption**	kW	0.21- 1.24	0.19- 1.32	0.25- 1.84	0.37- 2.80	0.38- 3.60
** : Test carried out at 15 °C air temperature, with a water inlet at 26 °C and a water outlet at 28 °C in order to define the water flow rate, the heating capacity and the consumption, according to FPP standards.						
Cold power consumption**	kW	2.2	3.72	4.3	6.2	7.69
Consumption***	kW	1.4	1.45	1.78	3.3	2.66
COP***		1.55	2.57	2.43	1.86	2.89
*** Test performed at 35 °C air temperature, with water inlet at 30 °C and water outlet at 29 °C.						
Body		ASA	ASA	ASA	ASA	ASA
Controller		Ecran Digital tactile - Digital Touch screen				
Gaz		R32	R32	R32	R32	R32
Exchanger		Titane Twisté - Twisted Titanium	Titane Twisté - Twisted Titanium	Titane Twisté - Twisted Titanium	Titane Twisté - Twisted Titanium	Titane Twisté - Twisted Titanium
Compressor		Rotatif Panasonic - Panasonic Rotary	Rotatif Panasonic - Panasonic Rotary	Rotatif Panasonic - Panasonic Rotary	Rotatif Mitsubishi - Mitsubishi Rotary	Rotatif Mitsubishi - Mitsubishi Rotary
Ventilation units		1	1	1	1	1
Ventilation rotation speed	T/mn	400-700	400-750	400-800	300-750	400-750
Mode		Warm/ Cold/ Auto	Warm/ Cold/ Auto	Warm/ Cold/ Auto	Warm/ Cold/ Auto	Warm/ Cold/ Auto
Operating range		-7°C-43°C	-7°C-43°C	-7°C-43°C	-7°C-43°C	-7°C-43°C
Noise (1m)	dB(A)	38-50	41-50	42-51	42-55	45-56

Power supply		Mono 220-240V/50HZ				
Regulator		Electronique - Electronic	Electronique - Electronic	Electronique - Electronic	Electronique - Electronic	Electronique - Electronic
Water flow	m ³ /H	2.5	2.7	3.5	5.2	5.6
Unit dimension	mm	1000/418/605	1000/418/605	1000/418/605	1046/453/767	1160/490/862
Package dimensions (l/L/h)	mm	1030/435/615	1030/435/615	1030/435/615	1130/480/780	1210/510/880
NW/GW	kg	43/54	47/58	51/62	66/79	74/88
Warranty		3 ans 3 years	3 ans - 3 years	3 ans - 3 years	3 ans - 3 years	3 ans - 3 years

2. Dimensiones de la bomba de calor

DC 35 - DC 55 - DC 75

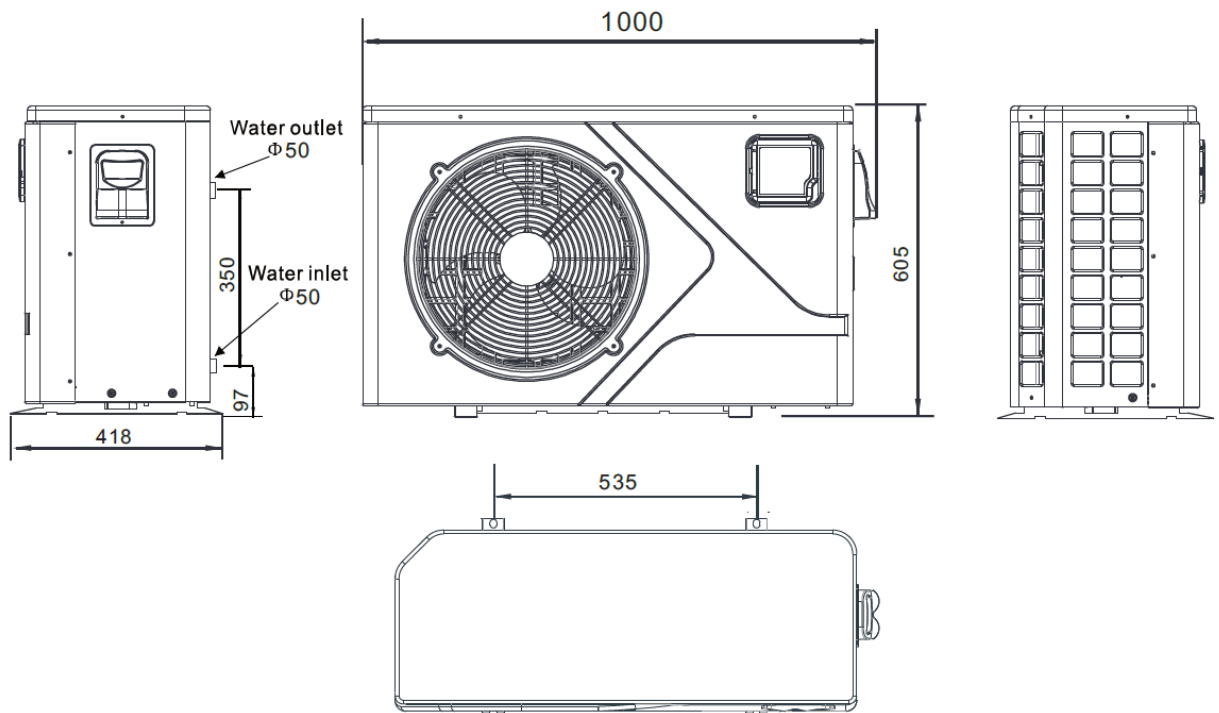

DC 95 :

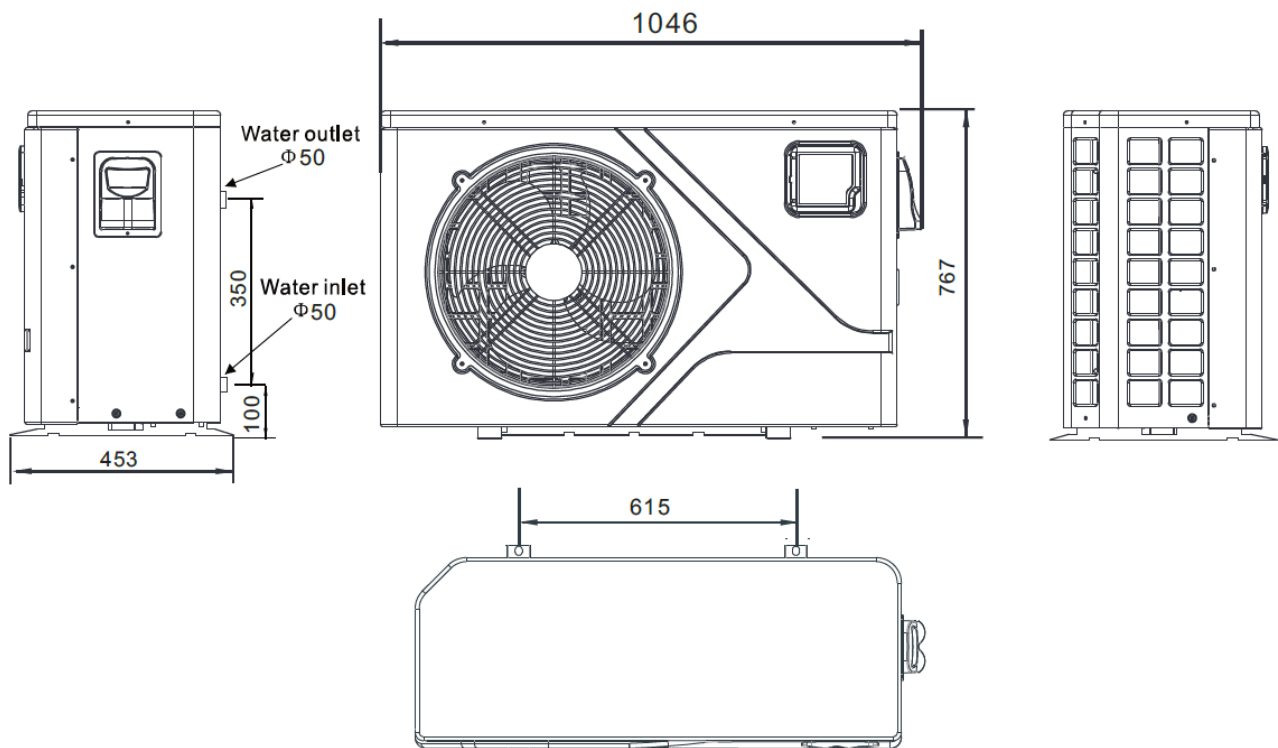

DC115

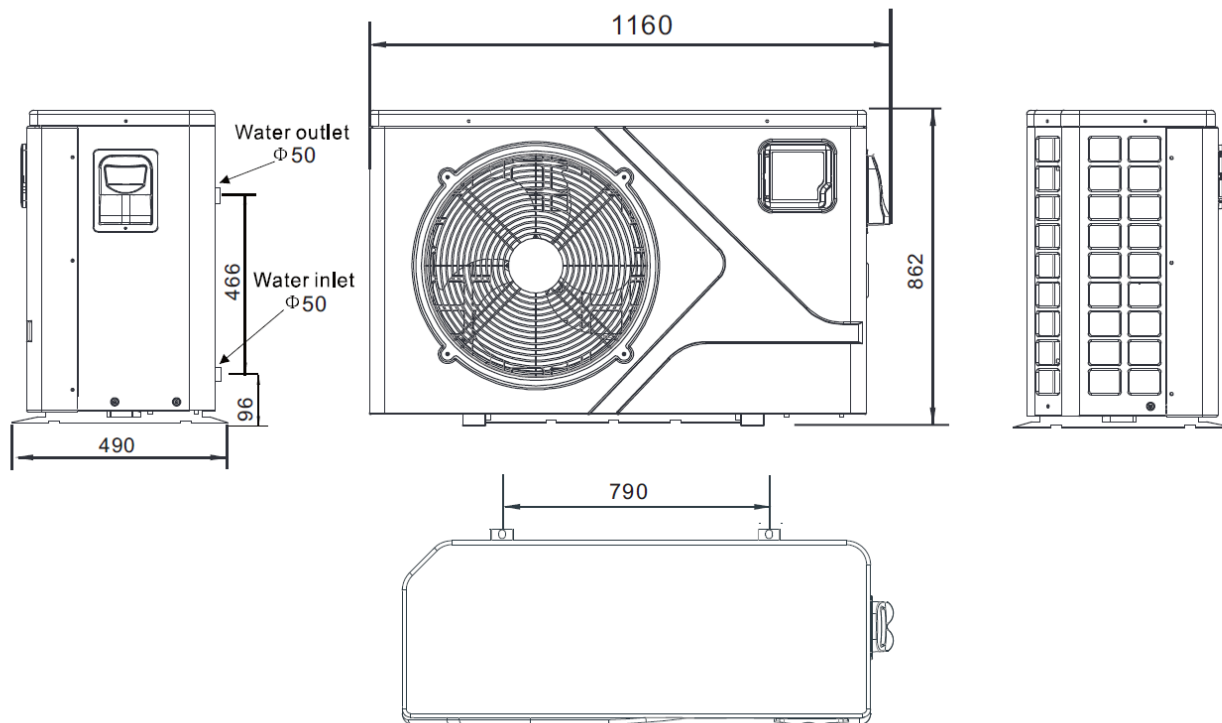

3. Instalación y conexiones

Al utilizar la piscina por primera vez, asegúrese de que la piscina está llena de agua

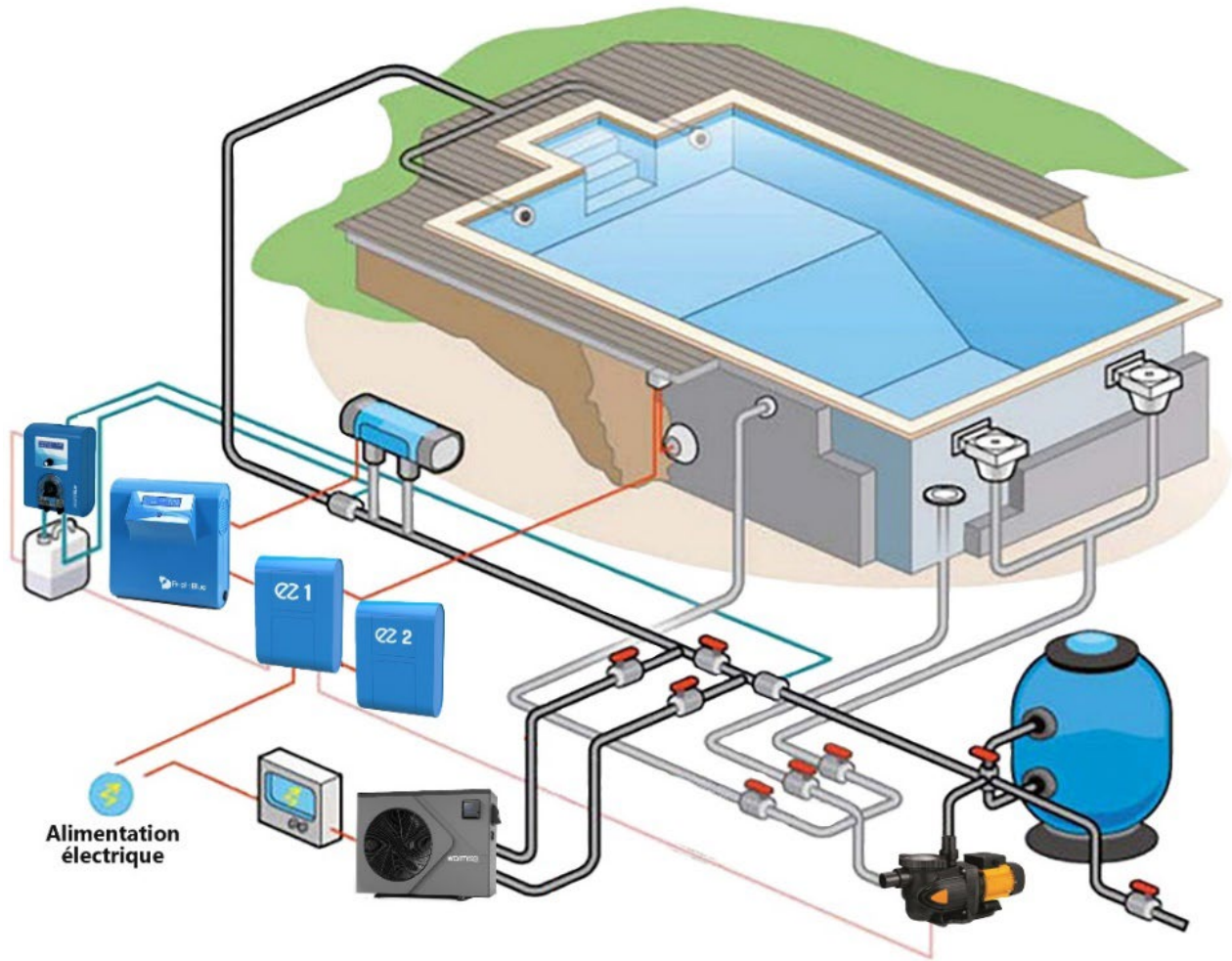

La elección de su bomba de calor debe haber sido determinada por un balance térmico personalizado para tener la certeza de que sus características corresponderán a sus necesidades. La empresa no puede en ningún caso responsabilizarse de un mal rendimiento si su dimensionamiento no se ha realizado gracias a un balance térmico personalizado y si no se han respetado las condiciones de uso indicadas durante el balance térmico.

encima del suelo.

Te recomendamos que utilices tacos y que drenes el condensado en una superficie para todo tipo de clima (que puede ser cubierta con grava).

Si una de estas recomendaciones no se aplica o no es aplicable, le pedimos que se ponga en contacto con el fabricante para comprobar si la instalación realizada o deseada no afectará al buen funcionamiento de su bomba de calor.

1.1 Conexión hidráulica

El intercambiador de calor de titanio de flujo exclusivo de la bomba de calor de la piscina no requiere ningún arreglo especial de fontanería, excepto el bypass. (Por favor, ajuste el caudal según la placa de características). La caída de presión del agua es inferior a 10 kPa con el caudal máximo. Dado que no hay calor residual ni temperatura de la llama, la unidad no requiere tuberías de disipación de calor de cobre. La tubería de PVC puede instalarse directamente en la unidad.

Ubicación: Conecte la unidad en la línea de descarga (retorno) de la bomba de la piscina, aguas abajo de todos los filtros y bombas de la piscina, y aguas arriba de todos los cloradores, ozonizadores o bombas de productos químicos. El modelo estándar está equipado con accesorios deslizantes que aceptan tubos de PVC de 32 mm o 50 mm para su conexión a las tuberías de filtración de la piscina o del spa.

Considere seriamente la posibilidad de añadir un racor de desconexión rápida a la entrada y a la salida de la unidad para permitir un fácil vaciado de la unidad para la preparación del invierno y para facilitar el acceso en caso de que sea necesario el mantenimiento.

Condensación: Como la bomba de calor enfría el aire unos 4 ó 5 grados, el agua puede condensarse en las aletas del evaporador. Si la humedad relativa es muy alta, esto puede suponer varios litros por hora. El agua bajará por las aletas hasta la bandeja de la base y saldrá por el accesorio de drenaje de condensado de plástico con púas situado en el lateral de la bandeja de la base.

Este accesorio está diseñado para aceptar un tubo de vinilo transparente de 20 mm que puede ser empujado a mano y dirigido a un desagüe apropiado. Es fácil confundir la condensación con una fuga de agua dentro de la unidad.

Nota: Una forma rápida de verificar que el agua es condensación es apagar la unidad y dejar la bomba de la piscina en funcionamiento. Si el agua deja de salir de la piscina, se trata de condensación.

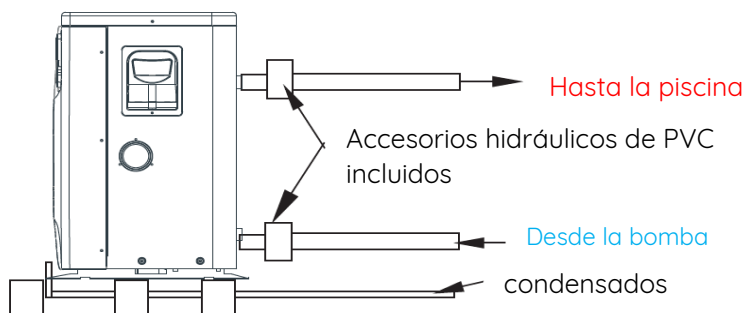

1.2 Conexión eléctrica



Importante : La conexión de su bomba de calor debe ser realizada por personal autorizado y cualificado. Compruebe que el cable que alimenta el local técnico tiene una sección suficiente para soportar el consumo adicional que requiere la máquina.

La bomba de calor debe alimentarse de un disyuntor de curva D independiente que puede estar en el cuadro eléctrico principal equipado con un diferencial o en un cuadro independiente conectado al cuadro principal, que tendrá un diferencial. Si no es el caso, añada un diferencial al cuadro independiente de su bomba de calor.

Référéce	Power Supply	D-Curve circuit breaker power	Cable section according to the distance between the circuit breaker and the heat pump		
			- 10 m	10 -15 m	+ 15 m
DC 35	Monophasé 230 V	16 Ampères	3G2.5 mm ²	3G2.5 mm ²	3G6 mm ²
DC 55	Monophasé 230 V	16 Ampères	3G2.5 mm ²	3G2.5 mm ²	3G6 mm ²
DC 75	Monophasé 230 V	20 Ampères	3G2.5 mm ²	3G2.5 mm ²	3G6 mm ²
DC 95	Monophasé 230 V	25 Ampères	3G2.5 mm ²	3G2.5 mm ²	3G6 mm ²
DC 115	Monophasé 230 V	25 Ampères	3G2.5 mm ²	3G2.5 mm ²	3G6 mm ²

Conexión eléctrica en el bloque de terminales de la bomba de calor

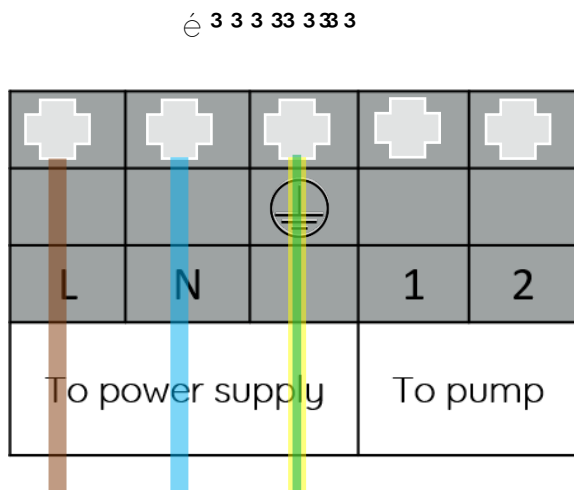

Desenroscar el mango para acceder a la conexión eléctrica

3 3333 333 3

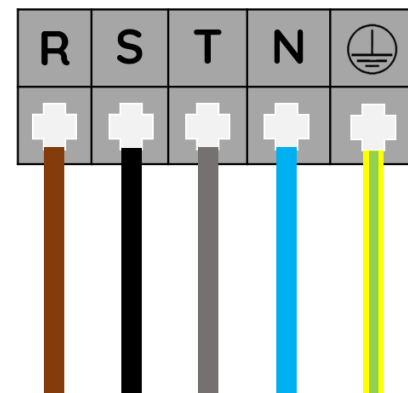

3 3333 3

ñ 3 3 3333 3

3 333

4. Puesta en servicio

Después de instalar correctamente su bomba de calor en el circuito hidráulico de su piscina o spa, la bomba de filtración de su piscina debe estar en funcionamiento para que el agua circule en el intercambiador de su bomba de calor.

1: Asegúrese de que las válvulas de su bomba de calor están ajustadas correctamente: By Pass: abierta al 50%, válvula de entrada: abierta al 100%, válvula de salida: abierta al 70%.

2: Encienda su bomba de filtración y compruebe que no hay fugas en el circuito hidráulico y que el agua circula correctamente por las boquillas de descarga de la piscina o spa.

3: Conecte la fuente de alimentación y luego pulse el botón ON/OFF del mando a distancia. Si la instalación se ha realizado correctamente, la bomba de calor debería encenderse inmediatamente.

4: Al cabo de unos minutos, el aire liberado por el ventilador debe ser significativamente más frío que el aire ambiente.

5: Cuando la bomba de calor esté funcionando, apague la bomba del filtro y la unidad debería detenerse.

6: Haga funcionar la bomba de filtración y la bomba de calor las 24 horas del día hasta que se alcance la temperatura deseada. Cuando se alcance la temperatura deseada, el aparato se ralentizará, cuando la temperatura se mantenga durante 45 minutos y ; el aparato se detendrá y se reiniciará automáticamente en cuanto la temperatura del agua sea 0,2 °C inferior a la temperatura establecida solicitada (Atención : su bomba de filtración debe estar en funcionamiento para que la bomba de calor funcione).

5. Guía del mando a distancia

5.1 Presentación general

Su bomba de calor está equipada con un control digital táctil que viene programado por defecto en modo caliente de fábrica.

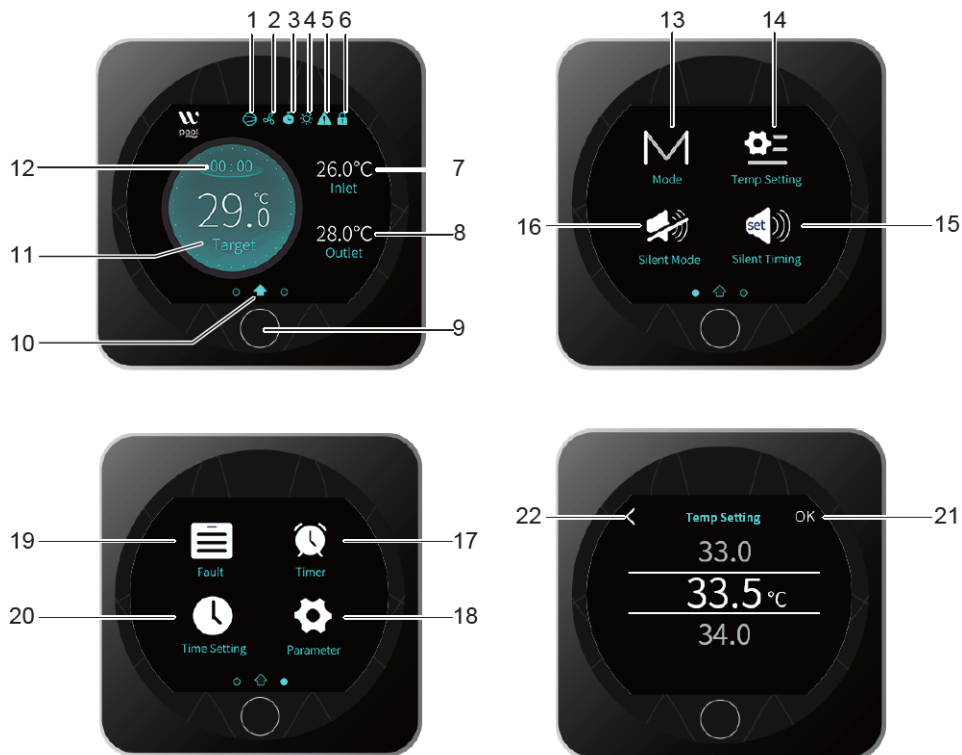

- 1: Indicador de funcionamiento del compresor
- 2: Ventilación
- 3 : Temporizador
- 4 : Modos de control de la temperatura: caliente - frío - automático
- 5 : Alarma
- 6 : Bloqueo de la pantalla
- 7 : Temperatura de entrada del agua
- 8 : Temperatura de salida del agua
- 9 : Encendido/apagado/retorno
- 10 : Pantalla principal
- 11: Temperatura de consigna
- 12: Hora del sistema
- 13: Modo de funcionamiento
- 14: Cambio de temperatura de consigna
- 15: Ajustes del modo silencioso
- 16: Activar el modo silencioso
- 17: Programación de la hora
- 18: Parámetros avanzados
- 19: Lista de códigos de error
- 20 : Ajustar la fecha y la hora

21 : Confirmar

22 Atrás (ADVERTENCIA los ajustes que está modificando en ese momento no se guardarán



OFF :

Cuando la bomba de calor está en modo de espera, verá OFF en la pantalla. Después de un rato, la pantalla se apagará y pasará al modo de espera.

ON :

Cuando la bomba de calor está en funcionamiento, la pantalla se vuelve azul.

Para pasar de un modo a otro, pulse el botón central negro durante 0,5 segundos.

5.2 Ajustar la fecha y la hora

La fecha y la hora se pueden ajustar en modo ON o OFF



Pulse el botón central una vez para volver a la pantalla principal.

5.3 Ajuste del programa de tiempo

Esta función debe ser programada si desea programar las horas de funcionamiento de su bomba de calor (ATENCIÓN: La bomba de filtración de su piscina debe estar funcionando para que su bomba de calor se ponga en marcha). Puede programar una hora de arranque y una hora de parada para su bomba de calor.



Azul : Activado
Gris : Desactivado

Pulse dos veces el botón central para volver a la pantalla principal.



5.4 Ajuste de la temperatura de consigna

La temperatura de consigna se puede modificar en modo ON o OFF con una precisión de 0,5°C.



Pulse el botón central una vez para volver a la pantalla principal

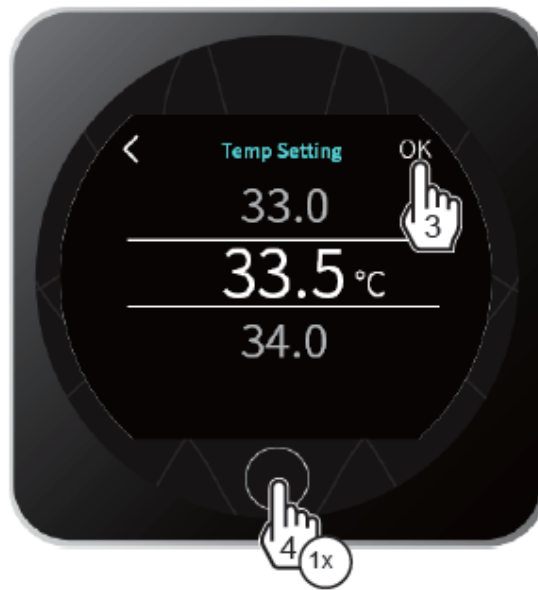

Pulse el botón central una vez para volver a la pantalla principal

5.5 Selección del modo de temperatura



Pulse el botón central una vez para volver a la pantalla principal

5.6 Selección del modo de temperatura

La pantalla se puede bloquear o desbloquear en modo ON o OFF



Pulse el botón central una vez para volver a la pantalla principal

5.7 Configurar el modo silencioso

El modo Silencioso permite que la bomba de calor funcione de forma muy económica y silenciosa cuando la necesidad de calefacción es baja (sólo es necesario mantener la temperatura en condiciones meteorológicas muy favorables o necesidad específica de funcionamiento ultra silencioso)

Activación / Desactivación



Silencio activado



Silencio desactivado



Pulse una vez para volver a la pantalla principal



Pulse dos veces el botón central para volver a la pantalla principal. Una vez activado el ajuste, estará activo los 7 días de la semana..

5.8 Solución de problemas / códigos de error

Tenga en cuenta que algunas operaciones deben ser realizadas por técnicos autorizados.

Si la bomba de calor detecta un error, aparece un pequeño triángulo en la parte superior de la pantalla, como se indica a continuación:



Cuando el problema se resuelve, el error desaparece por sí mismo y el símbolo de error también desaparece.

Para borrar la lista de errores pulse el símbolo de la papelera

Pulse dos veces el botón central para volver a la pantalla principal

5.9 Lista de parámetros y códigos de error

Error / Fallo	Código	Motivo	Método de resolución
Fallo del sensor de temperatura de entrada del agua	P01	La sonda está dañada o en cortocircuito	Comprobar o cambiar la sonda
Fallo del sensor de temperatura de salida del agua	P02	La sonda está dañada o en cortocircuito	Comprobar o cambiar la sonda
Fallo de la sonda de temperatura ambiente	P04	La sonda está dañada o en cortocircuito	Comprobar o cambiar la sonda
Fallo del sensor de temperatura del intercambiador de calor 1	P05	La sonda está dañada o en cortocircuito	Comprobar o cambiar la sonda
Fallo de la sonda de temperatura del intercambiador 2	P15	La sonda está dañada o en cortocircuito	Comprobar o cambiar la sonda
Fallo de la sonda de temperatura SUT	P07	La sonda está dañada o en cortocircuito	Comprobar o cambiar la sonda
Fallo de la sonda de temperatura ET	P081	La sonda está dañada o en cortocircuito	Comprobar o cambiar la sonda
Fallo de la sonda ET (protección)	P 082	Sobrecarga del compresor	Compruebe si el sistema y el compresor funcionan correctamente
Fallo de la sonda de temperatura del anticongelante	P 09	La sonda está dañada o en cortocircuito	Compruebe o cambie la sonda
Fallo de la sonda de presión	PP	La sonda está dañada o en cortocircuito	Compruebe o cambie la sonda
Alta presión del compresor	E 01	Problema detectado en la presión del compresor	Compruebe los ajustes de las válvulas (By Pass abierto al 70% - Válvula de entrada de agua abierta al 100% y válvula de salida de agua abierta al 70%). Compruebe el sensor de presión y el sensor de caudal.
Baja presión del compresor	E 02	Problema detectado en la presión del compresor	Compruebe y/o cambie el sensor de presión y póngase en contacto con su instalador para que compruebe el circuito de refrigerante.
Interruptor de flujo de agua	E 03	Se ha detectado un error en el sensor de caudal	Compruebe la circulación del agua en su circuito hidráulico si la bomba de filtración no está encendida su bomba de calor no funcionará. Compruebe los ajustes de las válvulas (By Pass abierto 70% - Válvula de entrada de agua abierta 100% y válvula de salida de agua abierta 70%).

			Compruebe y/o sustituya el sensor de caudal Compruebe las temperaturas del agua y del ambiente
Protección de baja temperatura	E 05	La temperatura ambiente o del agua es demasiado baja	Check the water and ambient temperatures
Hueco de entrada y salida de agua	E 06	El caudal de agua no es suficiente	Compruebe la circulación del agua y los ajustes de las válvulas (By Pass abierto al 70% - Válvula de entrada de agua abierta al 100% y válvula de salida de agua abierta al 70%).
Protección antihielo	E 07	El caudal de agua no es suficiente	Compruebe la circulación del agua y los ajustes de las válvulas (By Pass abierto al 70% - Válvula de entrada de agua abierta al 100% y válvula de salida de agua abierta al 70%).
Protección anticongelante primaria	E 19	La temperatura ambiente es demasiado baja	Compruebe el sensor de temperatura ambiente
Protección anticongelante secundaria	E 29	La temperatura ambiente es demasiado baja	Compruebe el sensor de temperatura ambiente
Protección contra la sobrecarga del compresor	E 051	El compresor está sobrecargado	Compruebe si el sistema y el compresor funcionan con normalidad
Fallo de comunicación	E 08	El módulo de control de velocidad y la unidad de control no se comunican	Compruebe la conexión entre el control y la placa base
Fallo de comunicación (módulo de control de velocidad)	E 081	Temperatura ambiente demasiado baja	Compruebe la conexión
Temperatura ambiente demasiado baja	TP	Temperatura ambiente demasiado baja	Compruebe el sensor de temperatura ambiente
Fallo detectado en el sistema de ventilación	F 051	Se ha detectado un problema en el motor del ventilador	Compruebe si el motor del ventilador está roto o bloqueado
Fallo del motor del ventilador	F 031 F 032	El motor del ventilador está bloqueado, la conexión no parece funcionar normalmente	Sustituya el motor del ventilador Compruebe la conexión

Tenga en cuenta que algunas operaciones deben ser realizadas por técnicos autorizados.

Si se detecta un error que no figura en esta lista, póngase en contacto con su distribuidor.

6 Diagrama de interfaz

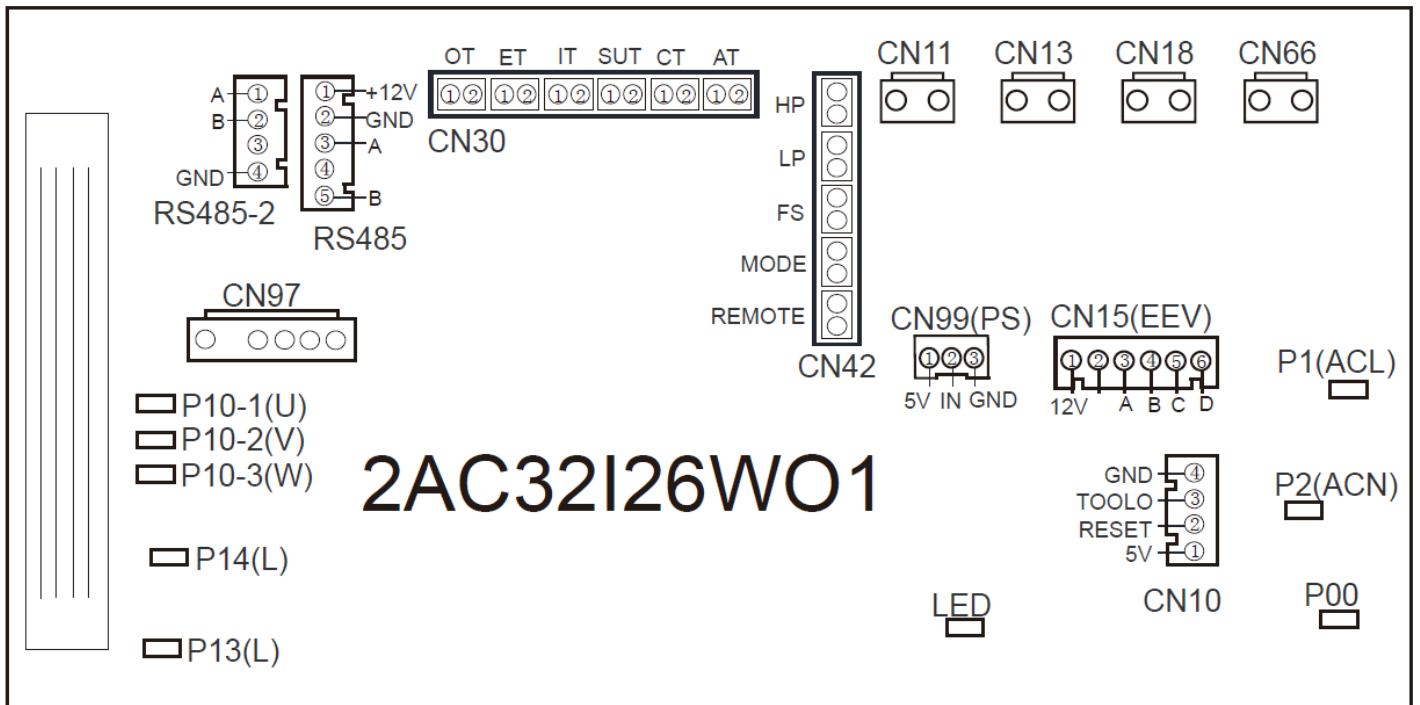
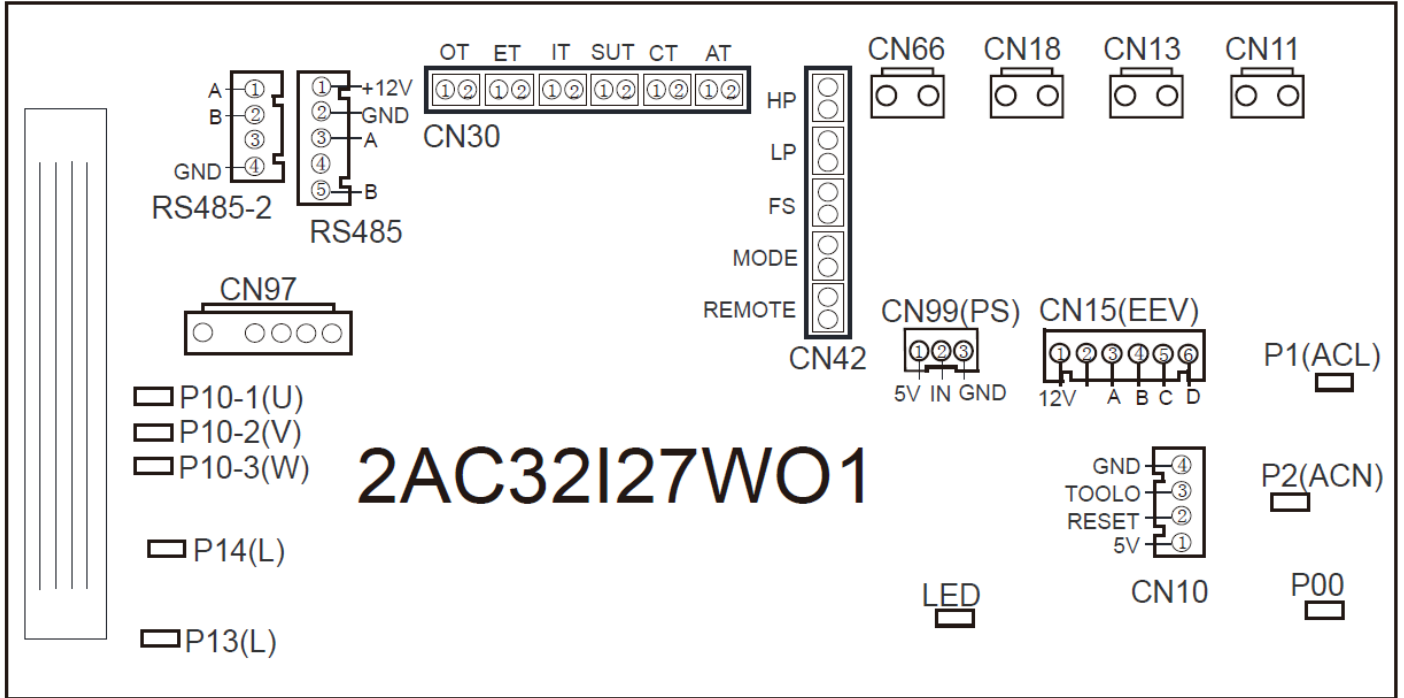

7 Diagrama de la placa base

Number	Sign	Meaning
01	P10-1/2/3(U/V/W)	Compressor
02	P13(L)	Resistance
03	P14(L)	Resistance
04	CN97	DC motor
05	RS485-2	The port for centralized control
06	RS485	Color line controller communication/WIFI
07	OT	Water output temperature
08	ET	System exhaust temperature
09	IT	Water input temperature
10	SUT	System suction temperature
11	CT	System fan coil temperature
12	AT	Ambient temperature
13	HP	System high pressure
14	LP	System low pressure
15	FS	Water flow switch
16	MODE	Mode switch
17	REMOTE	Emergency switch
18	CN66	Compressor signal
19	CN18	Water pump
20	CN13	Reserved
21	CN11	4-way valve
22	CN99	Low pressure sensor
23	CN15	Electronic expansion valve
24	P1	Live wire
25	P2	Neutral wire
26	CN10	Program port

8 Manual de uso del módulo WIFI



Descargar la aplicación Aquatemp



Parámetros técnicos

TENSIÓN DE FUNCIONAMIENTO: CD8V-12V (valor recomendado 12V) consumo máximo 1 A, corriente media en espera 50mA

RANGO DE TEMPERATURA: Temperatura de funcionamiento: -30 ~ +70; Temperatura de almacenamiento: -40 ~+85

INDICADOR LED: 4 luces, indicador de configuración de red, indicador de conexión al router, indicador de conexión al servidor en la nube, indicador de comunicación 485;

DIMENSIÓN (LxLxH) 78mmx63mmx24mm

En la parte posterior del módulo WIFI, hay un imán, se puede instalar en el interior o en el exterior, protegido de la luz solar directa;

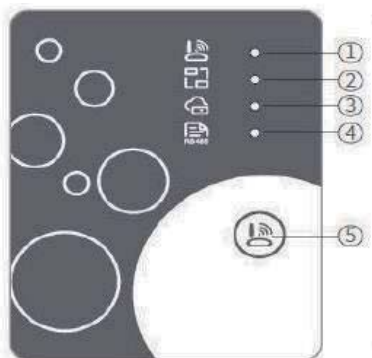

Luz	Significado	Luz larga	Luz intermitente	Off
1	Indicador de configuración de la red	Configuración de la red	Smart Link parametro	Terminado
2	Indicador de conexión al router	Normal	Abnormal	Off / In progress
3	Indicador de conexión al servidor de la nube	Normal	Abnormal	Off / In progress
4	Indicador de comunicación 485	Normal	Abnormal	Off / In progress
5	Botón de configuración, encendido	----	----	Pulse brevemente

Iniciar sesión: Utilice la dirección de correo electrónico y la contraseña para registrarse, iniciar sesión o restablecer la contraseña.

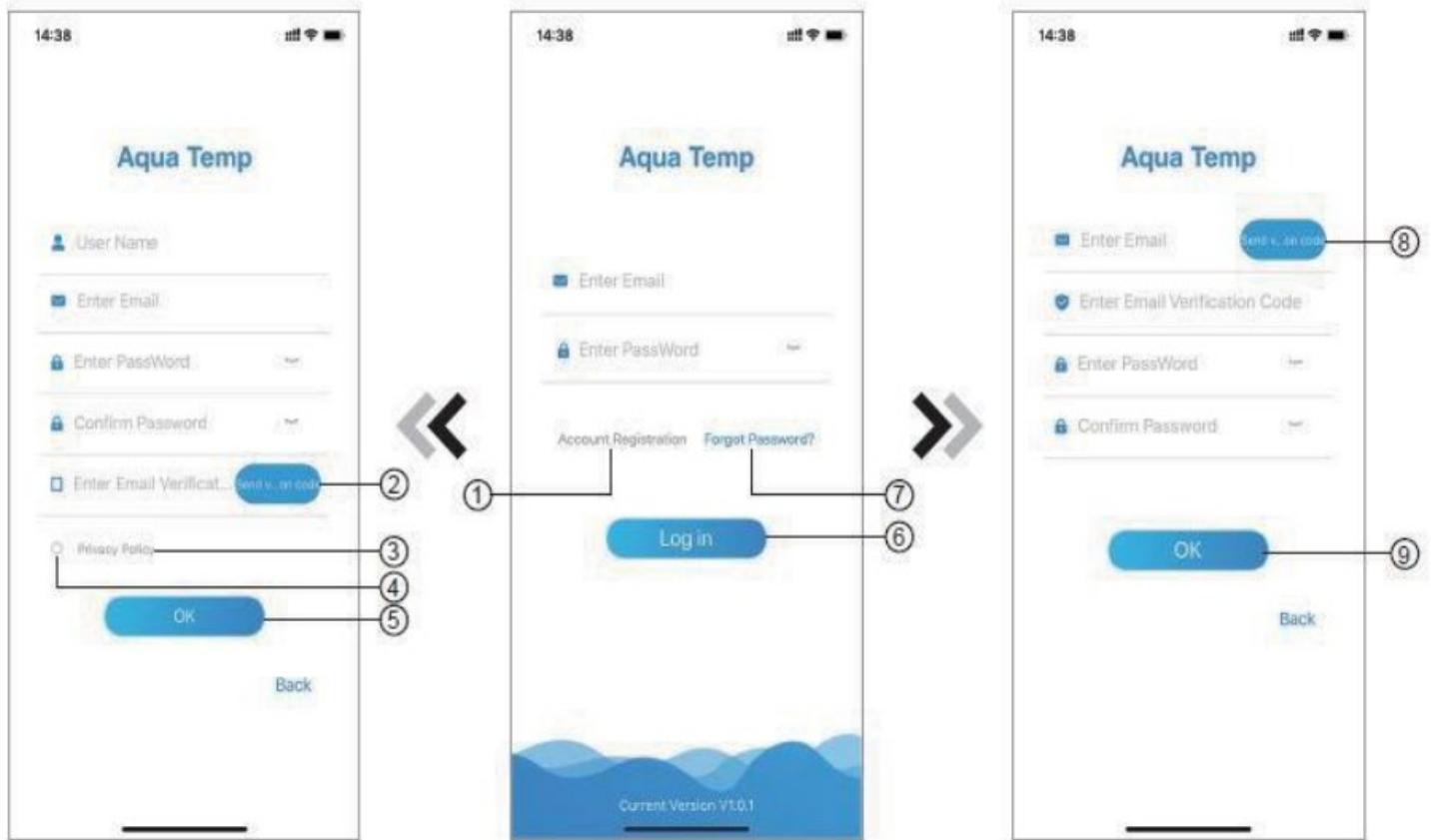

Registro de la cuenta: Para registrar una cuenta, haga clic en 1 (Fig.1) para entrar en la interfaz de registro de la cuenta, rellene la información y haga clic en 2 para recibir el código de verificación, mientras rellena la información solicitada, haga clic en 3 para leer los detalles de la política de privacidad, haga clic en 4 para aceptar, y haga clic en 5, el registro está completo. Tenga en cuenta que la validez de un código de verificación es de 15 minutos, por favor, rellene el código de verificación dentro de 15 minutos, de lo contrario tendrá que solicitar uno nuevo

Inicie sesión: Siga las instrucciones de la página (Fig.1), introduzca la dirección de correo electrónico registrada y la contraseña, haga clic y vaya a la lista de dispositivos. Si ha olvidado su contraseña, haga clic en "Contraseña olvidada" y siga las instrucciones.

Añada un dispositivo: Haga clic en añadir un nuevo dispositivo y siga las instrucciones para añadir el WIFI o el DTU.

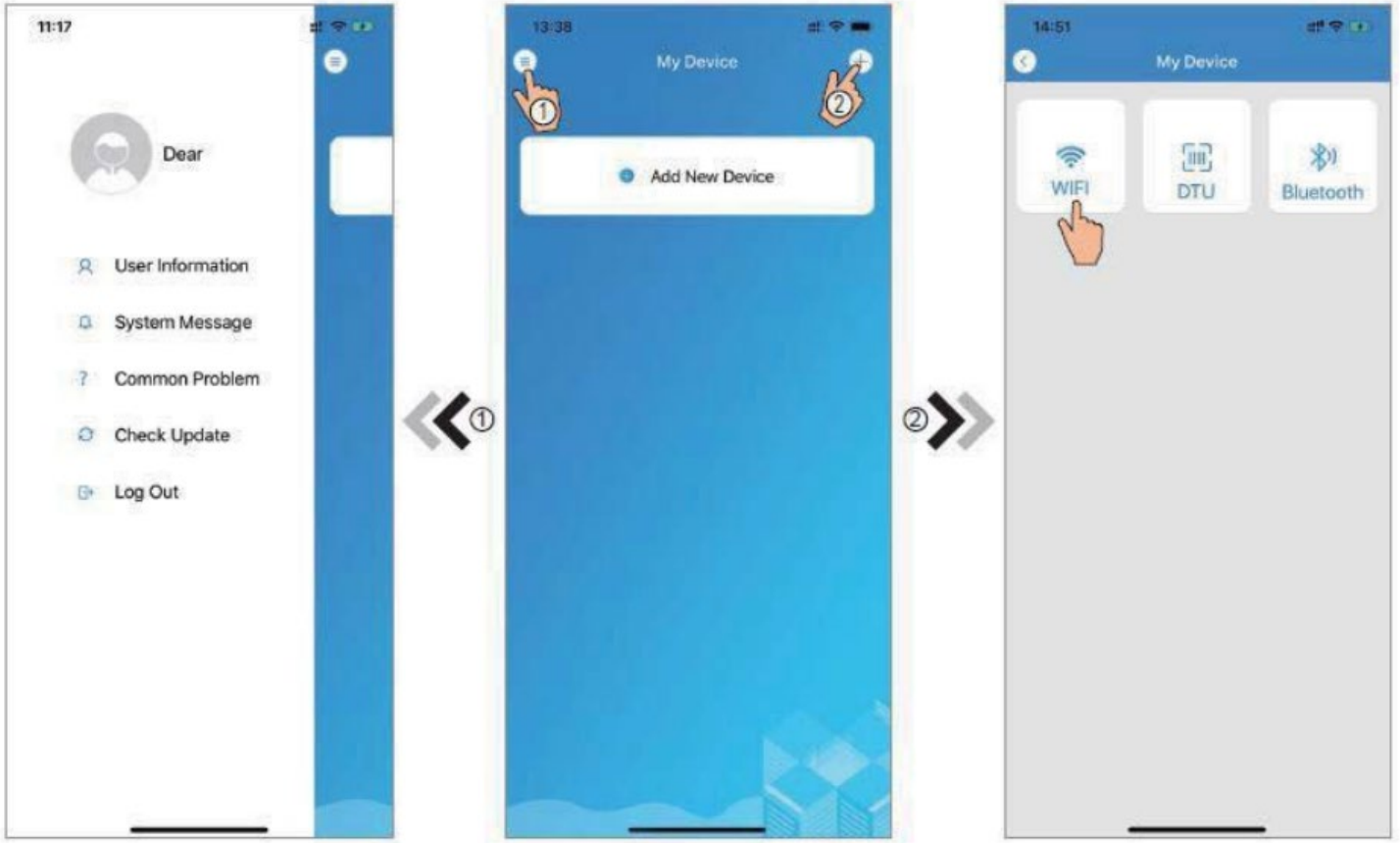

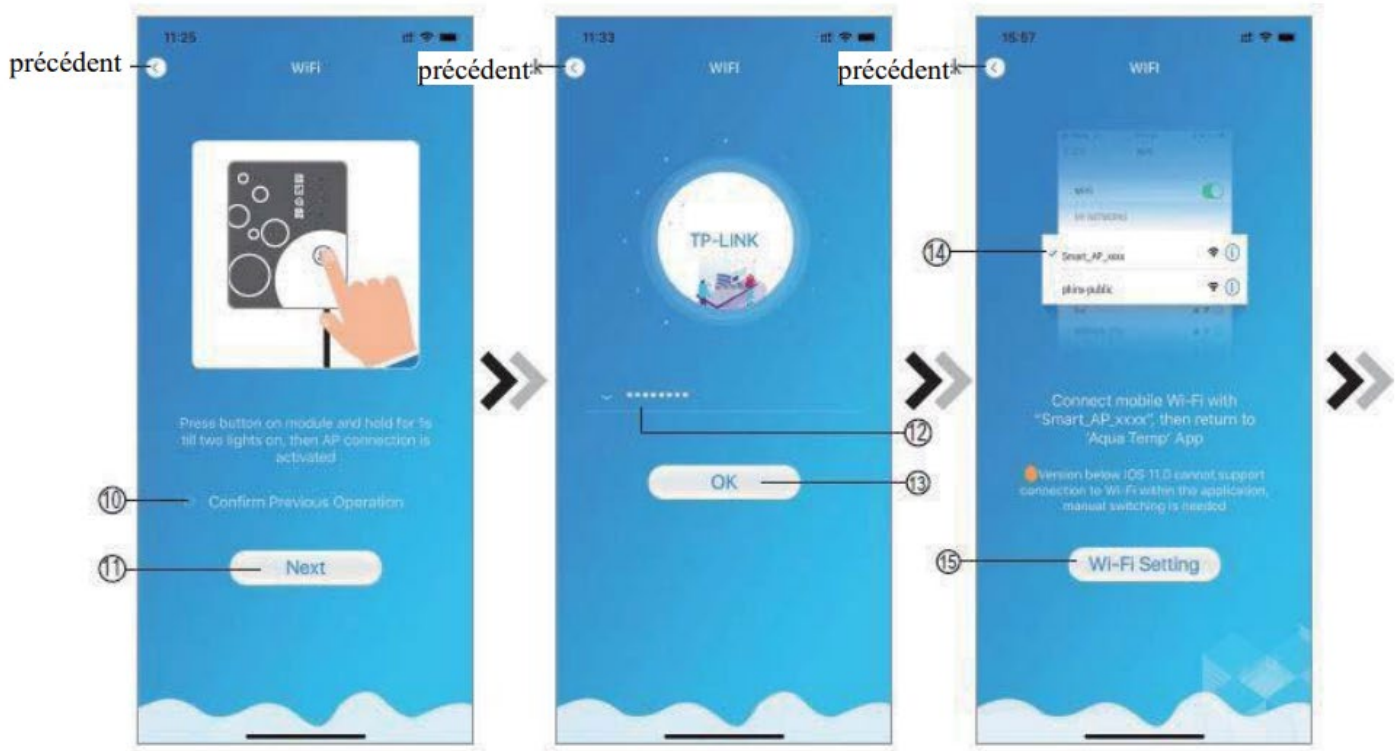

WiFi parametros :

Siga las instrucciones de la página. Mantenga pulsado el botón del módulo durante 1 segundo hasta que se enciendan dos luces. Pulse en 11 para confirmar, introduzca la contraseña WiFi para establecer la conexión y pulse en confirmar. Vaya a la configuración del sistema y conecte el WiFi especificado, seleccione "Smart_ AP_ xxx", pulse ok y siga las instrucciones para ir a la interfaz de configuración del WiFi.



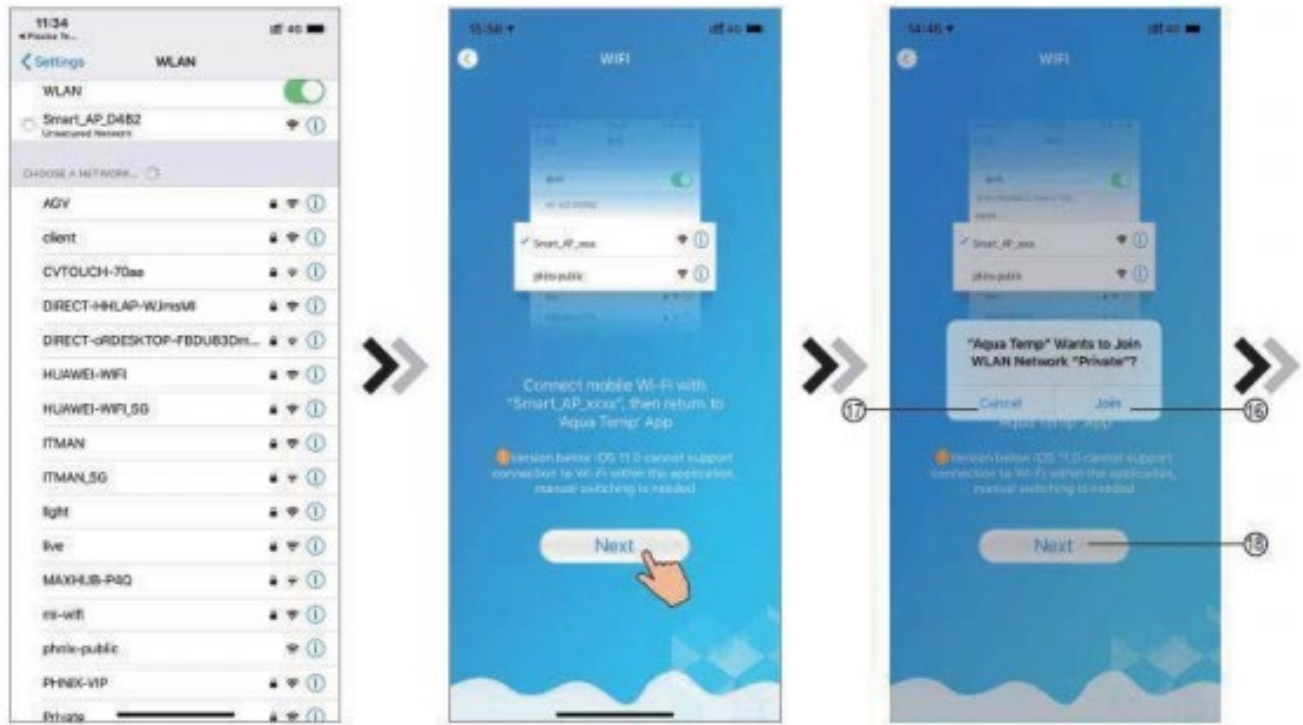

Gestión del dispositivo: Una vez completada la conexión WFI y DTU, vuelva a Mi Dispositivo.

Las operaciones de gestión del dispositivo son las siguientes:





	Nombre	Funciones
	Activar/Desactivar	Haga clic para activar/desactivar el dispositivo
	Modo de silencio	Haga clic aquí para activar el modo silencio
	Modo	Cambiar el modo: Calor, frío o automático
	Ajustes del temporizador	Haga clic para ir a la interfaz para activar/desactivar y silenciar el sonido y el temporizador
	Solución de problemas	Haga clic para acceder a la interfaz de resolución de problemas
	Menú	Haga clic para ampliar o reducir el menú

9 Garantía del fabricante

La garantía del fabricante es de 3 años. Además de esta garantía de las piezas, también ofrecemos una garantía de la mano de obra, que sólo se incluye en el caso de las devoluciones a nuestros talleres. En caso de que el fabricante solicite la devolución de la bomba de calor, los gastos de transporte para la devolución al taller corren a cargo del cliente y los gastos de devolución a las instalaciones del cliente corren a cargo del fabricante.

Esta garantía es exclusiva y sustituye a cualquier otra garantía implícita de comerciabilidad o idoneidad para un fin determinado y a cualquier otra garantía expresa o implícita. Los recursos previstos en esta garantía son exclusivos y constituyen la única obligación de Warmpac y cualquier otra representación hecha por cualquier persona no tendrá ninguna consecuencia..

10 Consejos de seguridad



No toque el ventilador mientras esté en funcionamiento, ya que podría causar lesiones. El aparato debe mantenerse fuera del alcance de los niños,

Compruebe regularmente la alimentación eléctrica y los cables de conexión de su bomba de calor. Si tiene alguna duda, póngase en contacto con su instalador,

En caso de servicio técnico, debe utilizar las piezas originales del fabricante.

El entorno de la bomba de calor debe estar siempre limpio, correctamente ventilado y libre de cualquier elemento que pueda influir negativamente en el rendimiento de la unidad.

Drene toda el agua del sistema hidráulico para limitar la congelación.

No coloque la unidad cerca de una fuente de calor o materiales inflamables, ya que la unidad contiene un gas refrigerante que puede provocar una explosión si entra en contacto con una fuente de calor o materiales inflamables. No fume cerca de la unidad.

Cuando se sustituyan los componentes eléctricos, deben ser adecuados para el uso previsto y con las especificaciones correctas. Deben seguirse en todo momento las instrucciones de mantenimiento y servicio del fabricante. En caso de duda, consulte al servicio técnico del fabricante para obtener ayuda.

Los siguientes controles deben aplicarse a las instalaciones que utilizan refrigerantes inflamables:

El tamaño de la carga es coherente con el tamaño de la sala en la que se instalan las piezas que contienen refrigerante;

Las salidas de la maquinaria y la ventilación funcionan correctamente y no están obstruidas; Si se utiliza un circuito de refrigerante indirecto, debe comprobarse la presencia de refrigerante en el circuito secundario; Las marcas en los equipos deben permanecer visibles y legibles. Las marcas y señales que sean ilegibles deben ser corregidas;

Las tuberías o componentes del refrigerante se instalan en una posición en la que no es probable que estén expuestos a ninguna sustancia que pueda corroer los componentes que contienen refrigerante, a menos que los componentes estén contruidos con materiales inherentemente resistentes a la corrosión o estén protegidos adecuadamente contra dicha corrosión.

Haga inspeccionar su bomba de calor regularmente por un instalador autorizado.

Al final de su vida útil, este aparato y el gas que contiene deben ser reciclados, póngase en contacto con su distribuidor.



Installations- und Benutzerhandbuch

DC 35 / DC 55 / DC 75 / DC 95 / DC 115



1, avenue de Londres, 13127 Vitrolles, FRANCE

Tel : + 33 4 28 70 69 99

info@warmpac.fr

www.wpool.fr

Sarl au capital de 62 500 Euros - N° TVA intracommunautaire : FR 08519634851 - SIRET:519 634 851 00017 - Code APE : 4



Warnung



Überprüfen Sie vor der Installation den Zustand Ihrer Wärmepumpe bei Erhalt und nehmen Sie die üblichen Vorbehalte vor. Wenn Sie irgendwelche Zweifel oder Probleme haben, senden Sie innerhalb von 48 Stunden ein AR-Schreiben an Ihren Installateur oder kontaktieren Sie den Hersteller. Nach Ablauf dieser Frist kann keine Reklamation mehr anerkannt werden.

Um unseren Kunden zuverlässige und qualitativ hochwertige Produkte anbieten zu können, wurde es nach strengen Herstellungs- und Produktionsstandards gefertigt.

Dieses Handbuch enthält alle Informationen, die für die Installation, Fehlersuche und Wartung des Geräts erforderlich sind. Bitte lesen Sie dieses Handbuch, bevor Sie das Gerät warten oder in Betrieb nehmen.

Die Installation und Inbetriebnahme Ihres Gerätes muss von qualifiziertem Fachpersonal unter Beachtung der geltenden Sicherheitsnormen durchgeführt werden. Bitte lesen Sie diese Anleitung sorgfältig durch. Wir übernehmen keine Verantwortung für Verletzungen oder Schäden an der Maschine, die auf Installationsfehler zurückzuführen sind. Die Nichtbeachtung dieser Anleitung führt zum Verlust der Garantie.



Verwenden Sie nur Original-Ersatzteile des Herstellers, andernfalls erlischt die Garantie.

Die Wärmepumpe darf nur zum Beheizen eines Schwimmbeckens verwendet werden. Sie darf nur zum Beheizen und Aufrechterhalten der Temperatur eines Schwimmbeckens unter den Bedingungen verwendet werden, die durch eine thermische Bewertung festgelegt wurden, die vor der Auswahl der Wärmepumpe mit einem Händler durchgeführt werden muss.

Diese Wärmepumpe entspricht den Herstellungs- und Kommunikationsnormen, die in der DTP10 der FPP und NFPAC festgelegt sind.

VORSICHT!

Verwenden Sie keine Mittel oder Verfahren, um das Abtauen oder Reinigen Ihrer Wärmepumpe zu beschleunigen. Nicht durchstechen, verbrennen oder in die Nähe einer Verbrennungsquelle bringen. Das Kältemittelgas darf keinen starken Geruch aufweisen.

Dieses Gerät ist nicht für die Benutzung durch Kinder oder Personen mit eingeschränkten körperlichen oder geistigen Fähigkeiten ohne Aufsicht bestimmt, da dies zu schweren Verletzungen oder zum Tod führen kann.

Der Hersteller und der Vertreiber haften nicht für Sach- und/oder Personenschäden, die durch unsachgemäße Verwendung/Installation verursacht werden.

Die Installation muss den örtlichen elektrischen Normen entsprechen und ordnungsgemäß geerdet sein. Das Gerät muss vor jedem Eingriff vom Stromnetz getrennt werden.

Richtlinie 2002/96/EG (WEEE): Das Symbol der durchgestrichenen Mülltonne auf der Unterseite des Geräts weist darauf hin, dass dieses Produkt am Ende seiner Nutzungsdauer getrennt vom Hausmüll entsorgt, einem Recyclingzentrum für elektrische und elektronische Geräte zugeführt oder beim Kauf eines gleichwertigen Geräts an den Händler zurückgegeben werden muss.

Richtlinie 2002/95/EG (RoHS): Dieses Produkt entspricht der Richtlinie 2002/95/EG (RoHS) zur Beschränkung der Verwendung von Schadstoffen in Elektro- und Elektronikgeräten.

Die Installation eines Schutzschalters ist notwendig, um das Risiko eines Brandes oder elektrischen Schlages zu vermeiden. Wenn das Netzteil beschädigt ist, lassen Sie es bitte von einem Fachmann austauschen, um Personen- und Sachschäden zu vermeiden.

1. Technische Daten

Referenz		DC35	DC55	DC75	DC95	DC115
Kapazität des Pools	Maxi	35m ³	55m ³	75m ³	95m ³	115m ³
Heizungsverbrauch*	kW	1.4- 6.8	1.3- 7.93	1.75- 10.90	3.21-15.81	3.21- 17.05
Verbrauch*	kW	0.14- 1.51	0.12- 1.37	0.16- 1.96	0.31- 3.03	0.32- 3.98
COP *		10.0 ~4.5	11.24-5.79	10.88- 5.56	10.3-5.22	10.01-4.82
* Test durchgeführt bei 27 °C Lufttemperatur, mit dem gleichen Unterschied in der Temperatur und Wasserfluss bei 15 °C erhalten.						
Nennstrom	A	1.02-5.18	0.9-6.0	1.2-8.6	1.5-13.3	2.0-17.5
Heizungsverbrauch**	kW	1.1- 5.2	0.96 ~ 6.46	1.52- 8.21	2.3- 12.14	2.07- 15.20
Verbrauch**	kW	0.21- 1.24	0.19- 1.32	0.25- 1.84	0.37- 2.80	0.38- 3.60
** : Test durchgeführt bei 15 °C Lufttemperatur, mit einem Wassereingang bei 26 °C und einem Wasserausgang bei 28 °C, um die Wasserdurchflussmenge, die Heizleistung und den Verbrauch zu definieren, nach FPP Normen.						
Leistungsaufnahme kalt**	kW	2.2	3.72	4.3	6.2	7.69
Verbrauch***	kW	1.4	1.45	1.78	3.3	2.66
COP***		1.55	2.57	2.43	1.86	2.89
*** Test durchgeführt bei 35 °C Lufttemperatur, mit einem Wassereinlass bei 30 °C und einem Wasserauslass bei 29 °C.						
Gehäuse		ASA	ASA	ASA	ASA	ASA
Regler		Ecran Digital tactile - Digital Touch screen				
Gaz		R32	R32	R32	R32	R32
Wärmetauscher		Titane Twisté - Twisted Titanium	Titane Twisté - Twisted Titanium	Titane Twisté - Twisted Titanium	Titane Twisté - Twisted Titanium	Titane Twisté - Twisted Titanium
Kompressor		Rotatif Panasonic - Panasonic Rotary	Rotatif Panasonic - Panasonic Rotary	Rotatif Panasonic - Panasonic Rotary	Rotatif Mitsubishi - Mitsubishi Rotary	Rotatif Mitsubishi - Mitsubishi Rotary
Belüftungseinheiten		1	1	1	1	1
Drehzahl der Lüftungsanlage	T/mn	400-700	400-750	400-800	300-750	400-750
Modus		Warm/ Cold/ Auto	Warm/ Cold/ Auto	Warm/ Cold/ Auto	Warm/ Cold/ Auto	Warm/ Cold/ Auto
Betriebsbereich		-7°C-43°C	-7°C-43°C	-7°C-43°C	-7°C-43°C	-7°C-43°C
Geräusch (1m)	dB(A)	38-50	41-50	42-51	42-55	45-56

Stromzufuhr		Mono 220-240V/50HZ				
Regler		Electronique - Electronic	Electronique - Electronic	Electronique - Electronic	Electronique - Electronic	Electronique - Electronic
Wasserdurchfluss	m ³ /H	2.5	2.7	3.5	5.2	5.6
Abmessungen der Einheit	mm	1000/418/605	1000/418/605	1000/418/605	1046/453/767	1160/490/862
Abmessungen der Verpackung (l/L/h)	mm	1030/435/615	1030/435/615	1030/435/615	1130/480/780	1210/510/880
NW/GW	kg	43/54	47/58	51/62	66/79	74/88
Garantie		3 ans 3 years	3 ans - 3 years	3 ans - 3 years	3 ans - 3 years	3 ans - 3 years

2. Abmessungen der Wärmepumpe

DC 35

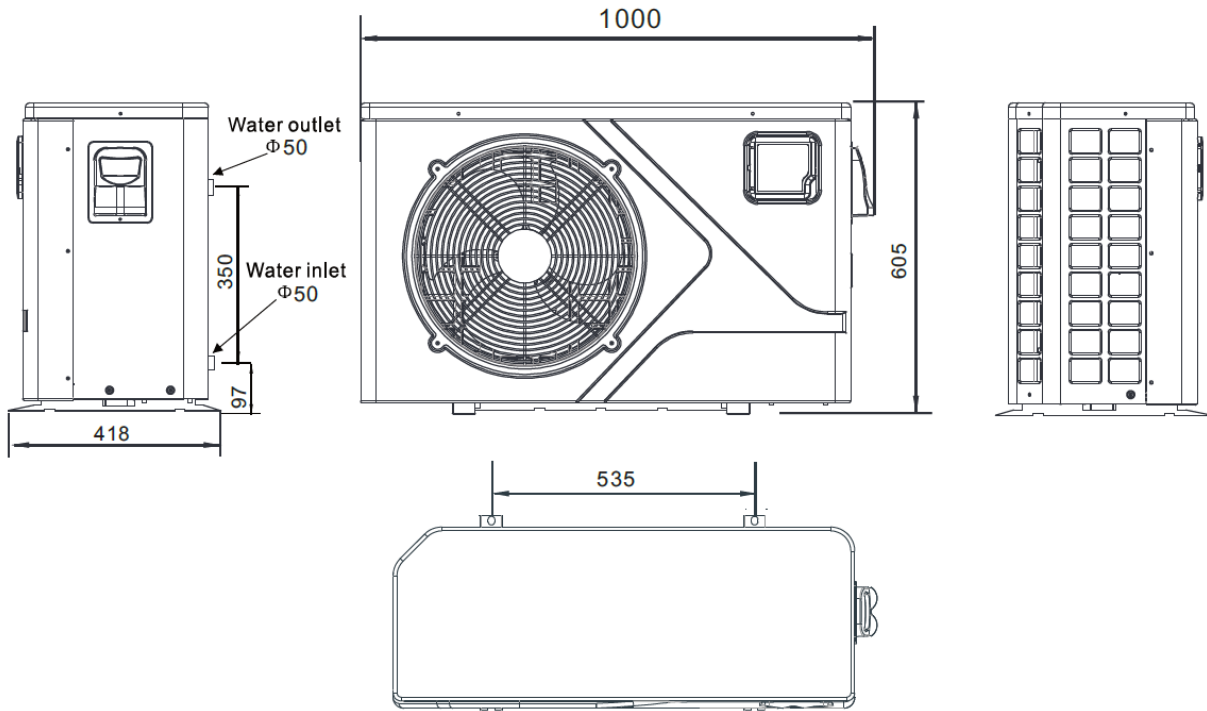

DC 95 :

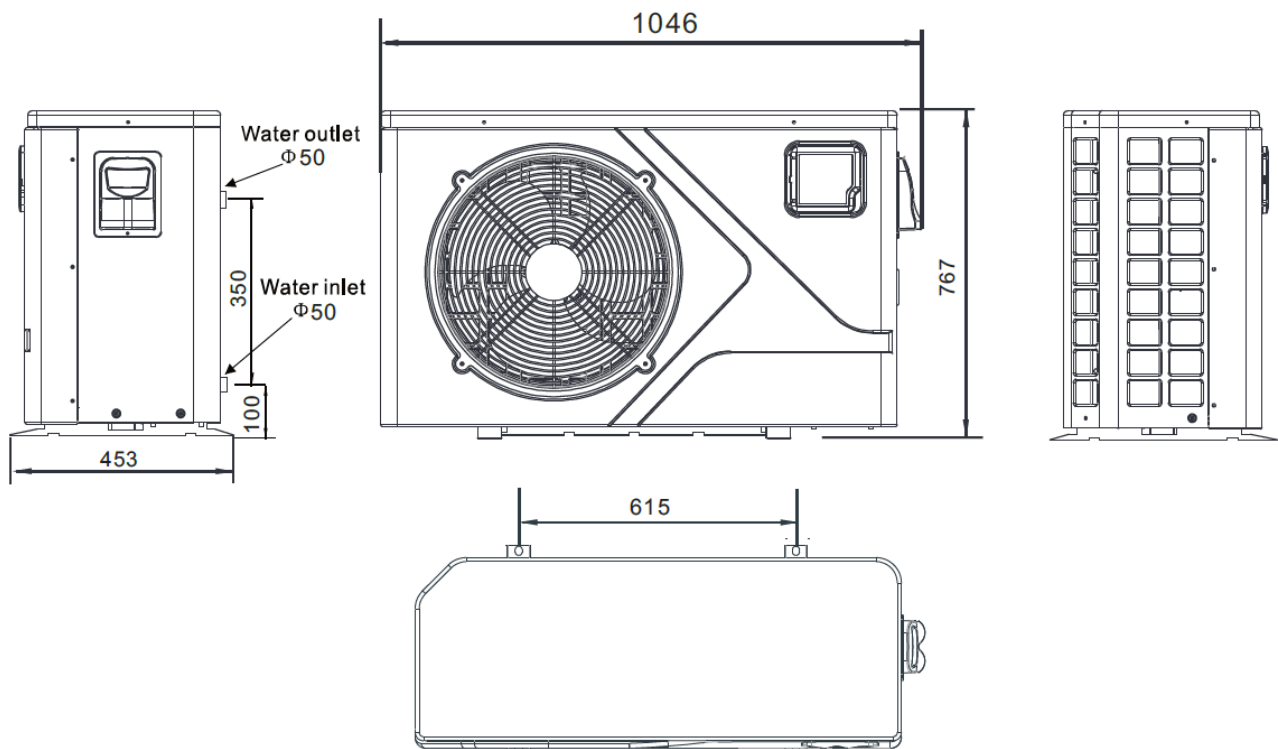

DC115

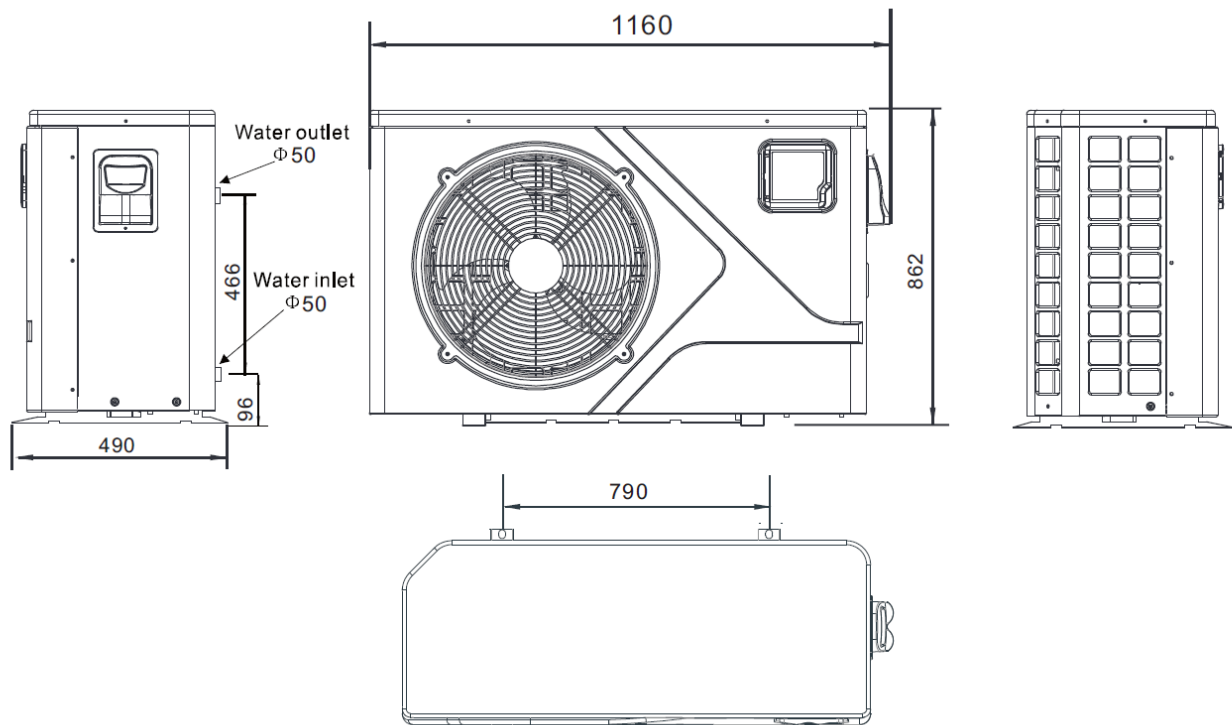

3. Einbau und Anschlüsse

Vergewissern Sie sich bei der ersten Benutzung des Schwimmbeckens, dass das Becken mit Wasser gefüllt ist.

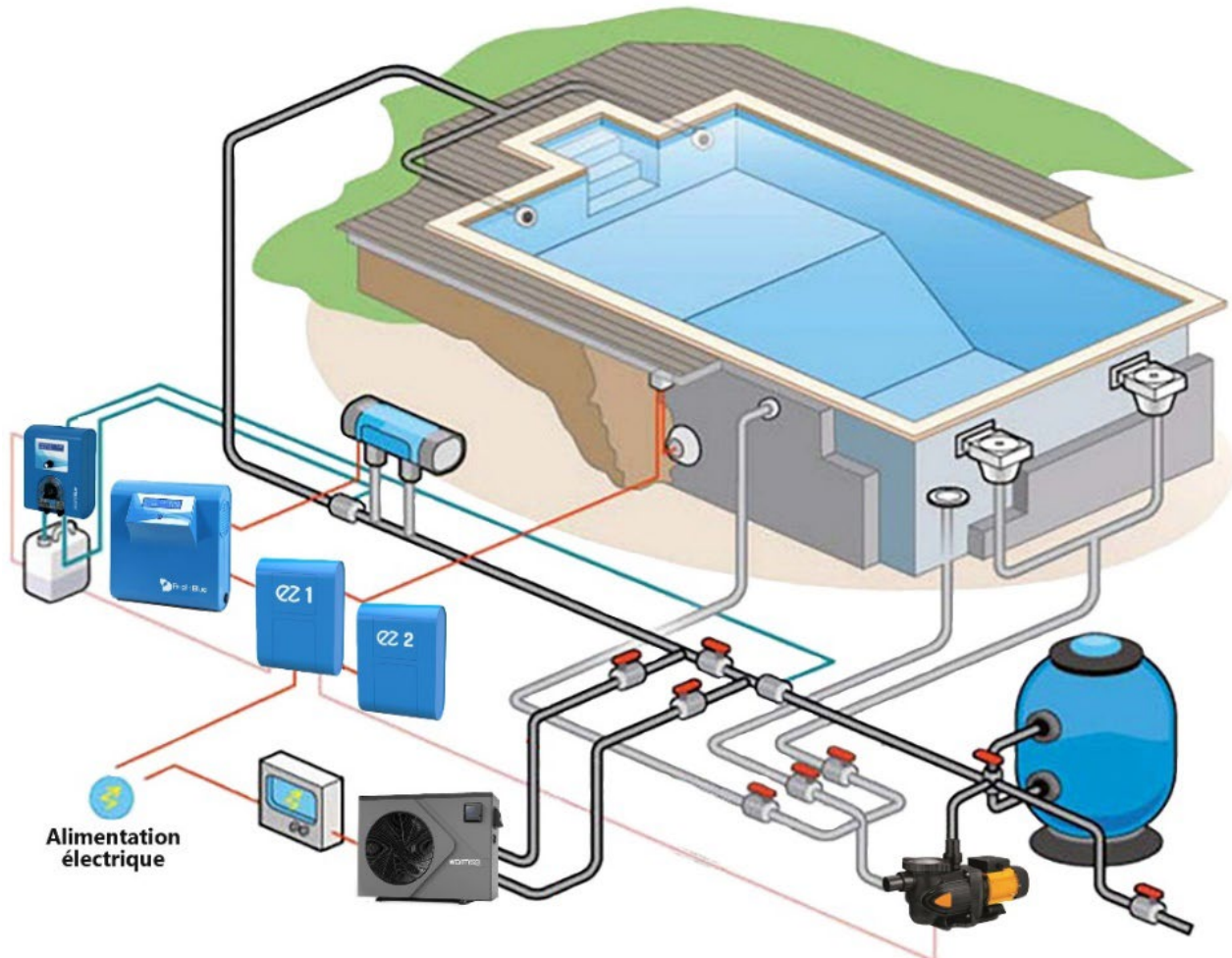



Die Wahl Ihrer Wärmepumpe muss durch eine persönliche Wärmebilanz bestimmt worden sein, um sicher zu sein, dass ihre Eigenschaften Ihren Bedürfnissen entsprechen. Das Unternehmen kann in keiner Weise für eine schlechte Leistung verantwortlich gemacht werden, wenn die Dimensionierung nicht auf der Grundlage einer individuellen Wärmebilanz erfolgt ist und wenn die in der Wärmebilanz angegebenen Nutzungsbedingungen nicht eingehalten wurden.

dem Boden.

Ihre Wärmepumpe muss im Freien aufgestellt werden und den Mindestabstand von 3 m ohne Hindernis vor dem Gebläse einhalten - 50 cm von der Wand für die Rückseite und 15 cm über

Wir empfehlen die Verwendung von Ständern und die Ableitung des Kondensats auf einer wetterfesten Oberfläche (die mit Kies abgedeckt werden kann).

If one of these recommendations is not applied or applicable, we ask you to contact the manufacturer to check whether the installation carried out or desired will not affect the proper functioning of your heat pump.

1.1 Hydraulische Verbindung

Der Titan-Wärmetauscher der Pool-Wärmepumpe mit exklusivem Durchfluss erfordert außer dem Bypass keine besondere Verrohrung. (Bitte stellen Sie die Durchflussmenge entsprechend dem Typenschild ein). Der Wasserdruckabfall beträgt weniger als 10 kPa bei maximaler Durchflussmenge. Da es keine Restwärme oder Flammentemperatur gibt, benötigt das Gerät keine Wärmeableitungsrohre aus Kupfer. PVC-Rohre können direkt an das Gerät angeschlossen werden.

Standort: Schließen Sie das Gerät an die Druckleitung (Rücklaufleitung) der Schwimmbadpumpe an, nach allen Filter- und Schwimmbadpumpen und vor allen Chlorgasdosierern, Ozongeneratoren oder Chemikalienpumpen. Das Standardmodell ist mit Aufsteckfittings ausgestattet, die 32 mm oder 50 mm PVC-Rohre für den Anschluss an die Pool- oder Whirlpool-Filterleitungen aufnehmen.

Es ist zu empfehlen, den Ein- und Auslass des Geräts mit einer Schnellkupplung zu versehen, damit das Gerät bei der Überwinterung leicht entleert werden kann und im Wartungsfall leichter zugänglich ist.

Kondenswasser: Da die Wärmepumpe die Luft um etwa 4 bis 5 Grad abkühlt, kann sich Wasser an den Verdampferlamellen niederschlagen. Wenn die relative Luftfeuchtigkeit sehr hoch ist, können dies mehrere Liter pro Stunde sein. Das Wasser fließt an den Lamellen hinunter in die Bodenwanne und durch den mit Widerhaken versehenen Kondensatablassstutzen aus Kunststoff an der Seite der Bodenwanne wieder heraus.

Dieser Anschluss ist für einen 20 mm dicken, durchsichtigen Vinylschlauch ausgelegt, der von Hand in einen geeigneten Abfluss geschoben werden kann. Kondenswasser kann leicht mit einem Wasseraustritt im Gerät verwechselt werden.

Hinweis: Sie können schnell feststellen, ob es sich bei dem Wasser um Kondenswasser handelt, indem Sie das Gerät ausschalten und die Poolpumpe laufen lassen. Wenn das Wasser nicht mehr aus dem Becken fließt, handelt es sich um Kondenswasser.

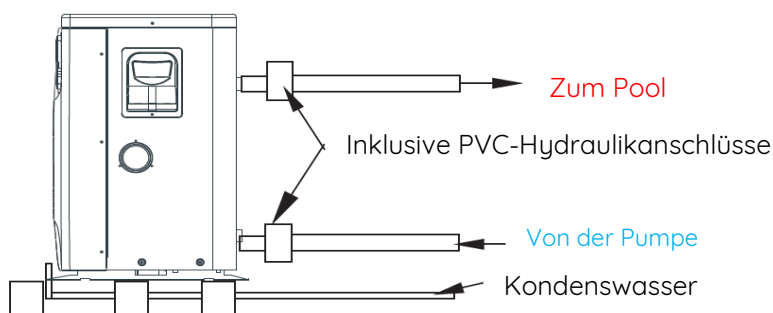

1.2 Elektrischer Anschluss



Wichtig: Der Anschluss Ihrer Wärmepumpe muss von autorisiertem und qualifiziertem Personal durchgeführt werden. Vergewissern Sie sich, dass das Kabel, das den Technikraum versorgt, einen ausreichend großen Querschnitt hat, um den von der Maschine benötigten zusätzlichen Verbrauch zu tragen.

Die Wärmepumpe muss über einen unabhängigen D-Kurven-Leistungsschalter versorgt werden, der sich entweder in der Hauptschalttafel befindet, die mit einem Differenzial ausgestattet ist, oder in einer unabhängigen Schalttafel, die mit der Hauptschalttafel verbunden ist und über ein Differenzial verfügt. Wenn dies nicht der Fall ist, fügen Sie der unabhängigen Schalttafel Ihrer Wärmepumpe ein Differenzial hinzu.

Referenz	Stromversorgung	Leistung des D-Kurven-Leistungsschalters	Kabelquerschnitt entsprechend der Entfernung zwischen dem Leistungsschalter und der Wärmepumpe.		
			- 10 m	10 -15 m	+ 15 m
DC 35	Monophasé 230 V	16 Ampères	3G2.5 mm ²	3G2.5 mm ²	3G6 mm ²
DC 55	Monophasé 230 V	16 Ampères	3G2.5 mm ²	3G2.5 mm ²	3G6 mm ²
DC 75	Monophasé 230 V	20 Ampères	3G2.5 mm ²	3G2.5 mm ²	3G6 mm ²
DC 95	Monophasé 230 V	25 Ampères	3G2.5 mm ²	3G2.5 mm ²	3G6 mm ²
DC 115	Monophasé 230 V	25 Ampères	3G2.5 mm ²	3G2.5 mm ²	3G6 mm ²

Elektrischer Anschluss an der Klemmleiste der Wärmepumpe

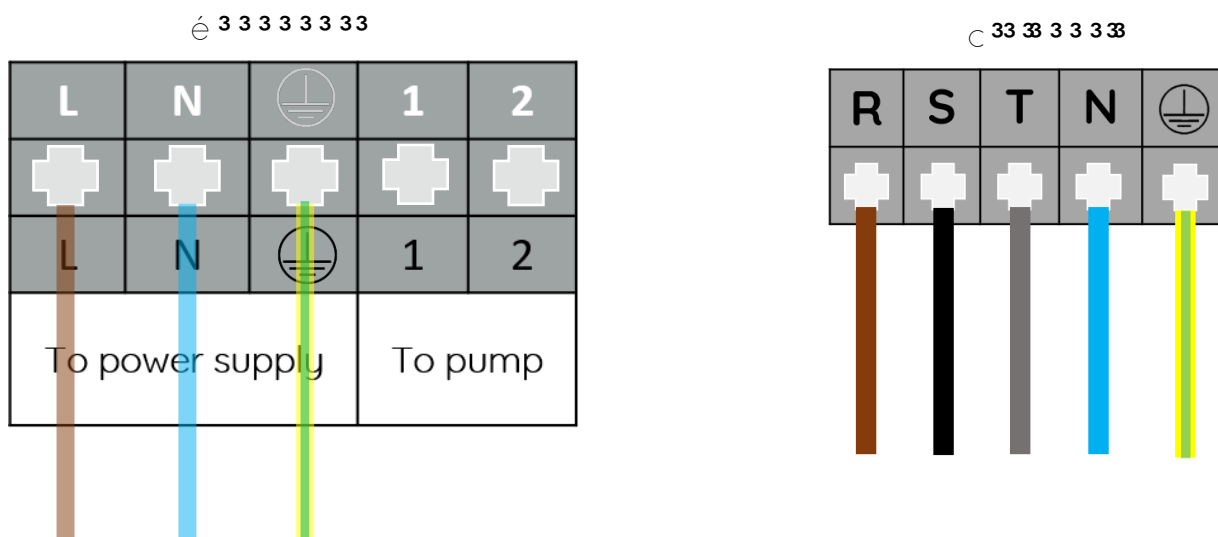

Schrauben Sie den Griff ab, um an den elektrischen Anschluss zu gelangen



4. Beauftragung

Nach der korrekten Installation Ihrer Wärmepumpe im Hydraulikkreislauf Ihres Schwimmbeckens oder Spas muss die Filterpumpe Ihres Schwimmbeckens in Betrieb sein, damit das Wasser im Wärmetauscher Ihrer Wärmepumpe zirkulieren kann.

- 1: Vergewissern Sie sich, dass die Ventile an Ihrer Wärmepumpe richtig eingestellt sind: Bypass: zu 50% geöffnet, Einlassventil: zu 100% geöffnet, Auslassventil: zu 70% geöffnet.
- 2: Schalten Sie Ihre Filterpumpe ein und prüfen Sie, ob der Hydraulikkreislauf dicht ist und das Wasser ordnungsgemäß durch die Auslassdüsen des Schwimmbeckens oder des Spas zirkuliert.
- 3: Schließen Sie die Stromversorgung an und drücken Sie dann die Taste ON/OFF auf der Fernbedienung. Wenn die Installation korrekt ausgeführt wurde, sollte sich die Wärmepumpe sofort einschalten.
- 4: Nach einigen Minuten sollte die vom Gebläse abgegebene Luft deutlich kühler sein als die Umgebungsluft.
- 5: Wenn die Wärmepumpe in Betrieb ist, schalten Sie die Filterpumpe aus, und das Gerät sollte stehen bleiben.
- 6: Lassen Sie die Filterpumpe und die Wärmepumpe 24 Stunden am Tag laufen, bis die gewünschte Temperatur erreicht ist. Wenn die gewünschte Temperatur erreicht ist, wird das Gerät langsamer, wenn die Temperatur 45 Minuten lang gehalten wird und ; das Gerät stoppt und startet automatisch wieder, sobald die Wassertemperatur 0,2 °C unter der gewünschten Temperatur liegt (Achtung: Ihre Filterpumpe muss in Betrieb sein, damit die Wärmepumpe funktioniert).

5. Anleitung für die Fernbedienung

5.1 Allgemeine Präsentation

Ihre Wärmepumpe ist mit einer digitalen Touch-Steuerung ausgestattet, die werkseitig auf den Warm-Modus programmiert ist.

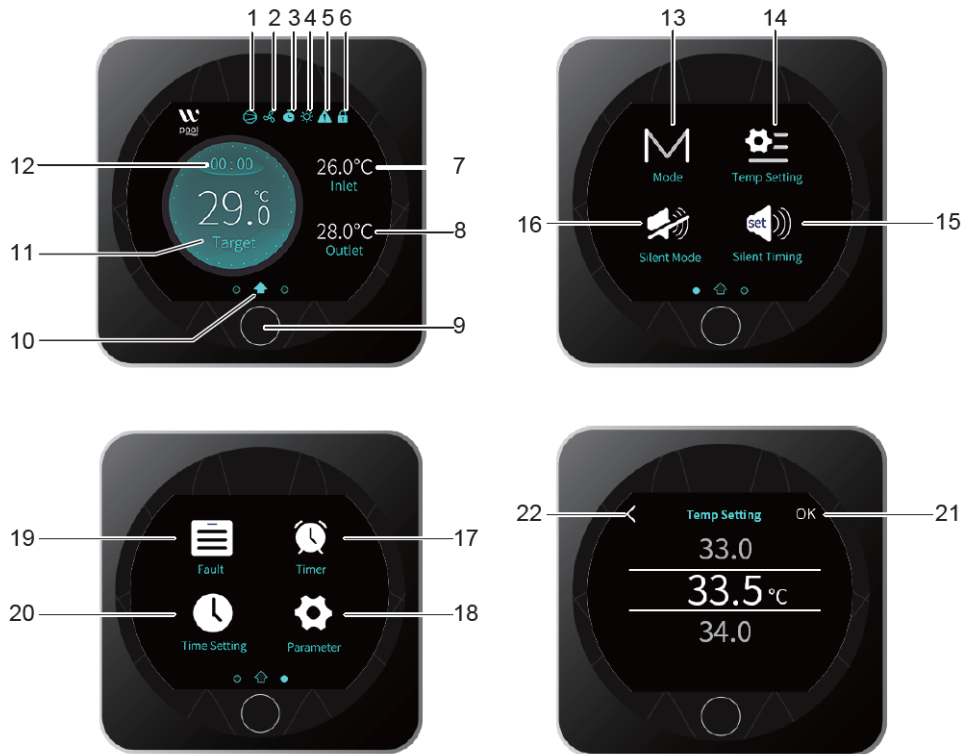

- 1: Betriebsanzeige des Kompressors
- 2: Belüftung
- 3: Zeitschaltuhr
- 4: Temperaturregelungsmodi: heiß - kalt - automatisch
- 5: Alarm
- 6: Display-Sperre
- 7: Wasserzulauftemperatur
- 8: Wasseraustrittstemperatur
- 9: Ein/Aus/Rücklauf
- 10: Hauptbildschirm
- 11: Sollwert Temperatur
- 12: Systemzeit
- 13: Betriebsart
- 14: Sollwerttemperaturänderung
- 15: Einstellungen Stiller Modus
- 16: Aktivieren des Silent-Modus
- 17: Zeitprogrammierung
- 18: Erweiterte Parameter
- 19: Fehlercodeliste
- 20: Einstellen von Datum und Uhrzeit

21 : Bestätigen

22 : Zurück (ACHTUNG: Die Einstellungen, die Sie gerade ändern, werden nicht gespeichert



OFF :

Wenn sich die Wärmepumpe im Standby-Modus befindet, wird auf dem Display OFF angezeigt. Nach einer Weile schaltet sich die Anzeige aus und geht in den Standby-Modus.

ON :

Wenn die Wärmepumpe in Betrieb ist, leuchtet das Display blau.
Um von einem Modus in den anderen zu wechseln, drücken Sie die schwarze mittlere

5.2 Einstellen von Datum und Uhrzeit

Datum und Uhrzeit können im ON- oder OFF-Modus eingestellt werden



Drücken Sie einmal die mittlere Taste, um zum Hauptbildschirm zurückzukehren.

5.3 Einstellung des Zeitprogramms

Diese Funktion muss programmiert werden, wenn Sie Betriebszeiten für Ihre Wärmepumpe festlegen möchten (ACHTUNG: Die Filterpumpe Ihres Schwimmbeckens muss in Betrieb sein, damit Ihre Wärmepumpe starten kann). Sie können eine Startzeit und eine Stoppzeit für Ihre Wärmepumpe programmieren.



Blau : Aktiv

Grau : Inaktiv

Drücken Sie zweimal die mittlere Taste, um zum Hauptbildschirm zurückzukehren.



5.4 Einstellen der Solltemperatur

Die Solltemperatur kann im ON- oder OFF-Modus mit einer Genauigkeit von 0,5°C geändert werden.



Drücken Sie die mittlere Taste einmal, um zum Hauptbildschirm zurückzukehren.

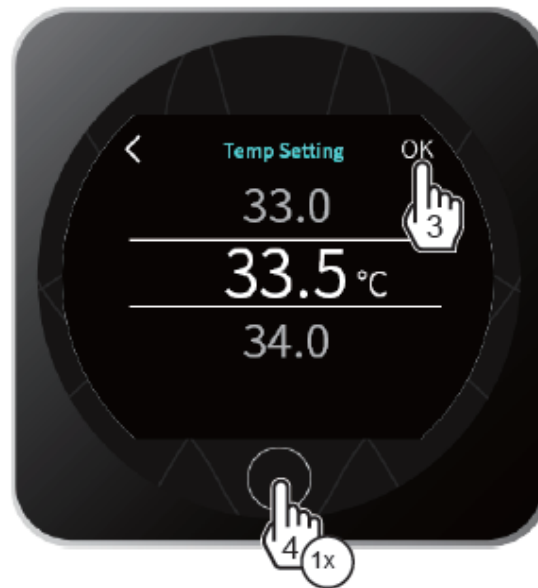

Drücken Sie die mittlere Taste einmal, um zum Hauptbildschirm zurückzukehren.

5.5 Auswahl des Temperaturmodus



Drücken Sie die mittlere Taste einmal, um zum Hauptbildschirm zurückzukehren.

5.6 Auswahl des Temperaturmodus

Der Bildschirm kann im EIN- oder AUS-Modus gesperrt oder entsperrt werden



Abgeschlossen



Ungesperrt

Drücken Sie die mittlere Taste einmal, um zum Hauptbildschirm zurückzukehren.

5.7 Einstellung des Ruhemodus

Der Silent-Modus ermöglicht einen sehr sparsamen und leisen Betrieb der Wärmepumpe bei geringem Heizbedarf (nur bei sehr günstigen Witterungsbedingungen oder bei besonderem Bedarf an besonders leisem Betrieb ist eine Temperaturhaltung erforderlich)

Aktivierung/Deaktivierung



Stille aktiviert



Stille inaktiviert



Einmal drücken, um zum Hauptbildschirm zurückzukehren



Drücken Sie zweimal die mittlere Taste, um zum Hauptbildschirm zurückzukehren. Sobald die Einstellung aktiviert ist, ist sie 7 Tage pro Woche aktiv.

5.8 Fehlersuche / Fehlercodes

Bitte beachten Sie, dass einige Vorgänge von autorisierten Technikern durchgeführt werden müssen.

Wenn die Wärmepumpe einen Fehler feststellt, erscheint oben auf dem Bildschirm ein kleines Dreieck wie folgt:



Wenn das Problem gelöst ist, verschwindet der Fehler von selbst und das Fehlersymbol verschwindet ebenfalls.

Um die Fehlerliste zu löschen, klicken Sie auf das Mülleimersymbol

Drücken Sie zweimal die mittlere Taste, um zum Hauptbildschirm zurückzukehren

5.9 Liste der Parameter und Fehlercodes

Error / Failure	Code	Motiv	Methode der Auflösung
Fehler am Sensor für die Wassereintrittstemperatur	P01	Die Sonde ist beschädigt oder kurzgeschlossen	Prüfen oder wechseln Sie die Sonde
Fehler am Sensor für die Wasseraustrittstemperatur	P02	Die Sonde ist beschädigt oder kurzgeschlossen	Prüfen oder wechseln Sie die Sonde
Fehler des Umgebungstemperaturfühlers	P04	Die Sonde ist beschädigt oder kurzgeschlossen	Prüfen oder wechseln Sie die Sonde
Fehler des Wärmetauscher-temperaturfühlers 1	P05	Die Sonde ist beschädigt oder kurzgeschlossen	Prüfen oder wechseln Sie die Sonde
Fehler Temperatursensor Wärmetauscher 2	P15	Die Sonde ist beschädigt oder kurzgeschlossen	Prüfen oder wechseln Sie die Sonde
Fehler Temperaturfühler SUT	P07	Die Sonde ist beschädigt oder kurzgeschlossen	Prüfen oder wechseln Sie die Sonde
Fehler am ET-Temperaturfühler	P081	Die Sonde ist beschädigt oder kurzgeschlossen	Prüfen oder wechseln Sie die Sonde
Fehler am ET-Fühler (Schutz)	P 082	Überlastung des Verdichters	Prüfen Sie, ob das System und der Kompressor richtig funktionieren
Fehler des Frostschutztemperaturfühlers	P 09	Die Sonde ist beschädigt oder kurzgeschlossen	Prüfen oder wechseln Sie die Sonde
Fehler am Drucksensor	PP	Die Sonde ist beschädigt oder kurzgeschlossen	Prüfen oder wechseln Sie die Sonde
Hochdruck des Verdichters	E 01	Verdichterdruckproblem erkannt	Überprüfen Sie die Ventileinstellungen (Bypass offen 70% - Wassereinlassventil offen 100% und Wasserauslassventil offen 70%). Überprüfen Sie den Drucksensor und den Durchflusssensor.
Kompressor-Niederdruck	E 02	Problem beim Verdichterdruck erkannt	Überprüfen und/oder ersetzen Sie den Drucksensor und wenden Sie sich an Ihren Installateur, um den Kältemittelkreislauf zu überprüfen.
Wasserströmungsschalter	E 03	Fehler am Durchflusssensor erkannt	Prüfen Sie die Wasserzirkulation in Ihrem Hydraulikkreislauf, wenn die Filterpumpe nicht eingeschaltet ist, wird Ihre Wärmepumpe nicht funktionieren. Überprüfen Sie die Ventileinstellungen (Bypass offen 70% - Wassereinlassventil offen 100% und Wasserauslassventil offen 70%). Prüfen und/oder

			ersetzen Sie den Durchflusssensor
Schutz vor niedriger Temperatur	E 05	Die Umgebungs- oder Wassertemperatur ist zu niedrig	Prüfen Sie die Wasser- und Umgebungstemperatur
Wassereinlass- und -auslassspalt	E 06	Der Wasserdurchfluss ist nicht ausreichend	Überprüfen Sie die Wasserzirkulation und die Ventileinstellungen (Bypass offen 70% - Wassereinlassventil offen 100% und Wasserauslassventil offen 70%).
Anti-Frost-Schutz	E 07	Der Wasserdurchfluss ist nicht ausreichend	Überprüfen Sie die Wasserzirkulation und die Ventileinstellungen (By Pass offen 70% - Wassereinlassventil offen 100% und Wasserauslassventil offen 70%).
Primärer Frostschutz	E 19	Die Umgebungstemperatur ist zu niedrig	Prüfen Sie den Umgebungstemperatursensor
Sekundärer Frostschutz	E 29	Die Umgebungstemperatur ist zu niedrig	Prüfen Sie den Umgebungstemperatursensor
Überlastungsschutz des Verdichters	E 051	Der Kompressor ist überlastet	Prüfen Sie, ob das System und der Kompressor normal funktionieren.
Kommunikationsfehler	E 08	Communication failure Kommunikationsfehler zwischen Steuerung und Hauptplatine	Überprüfen Sie die Verbindung zwischen der Steuerung und der Hauptplatine
Kommunikationsstörung (Drehzahlregelmodul)	E 081	Drehzahlregelungsmodul und Steuereinheit kommunizieren nicht miteinander	Überprüfen Sie den Anschluss
Raumtemperatur zu niedrig	TP	Umgebungstemperatur zu niedrig	Prüfen Sie den Raumtemperaturfühler
Störung im Lüftungssystem erkannt	F 051	Es wurde ein Problem mit dem Lüftermotor festgestellt	Prüfen Sie, ob der Ventilatormotor defekt oder blockiert ist.
Fehler im Ventilatormotor	F 031 F 032	Der Gebläsemotor ist blockiert, die Verbindung scheint nicht normal zu funktionieren	Den Gebläsemotor auswechseln Prüfen Sie den Anschluss

Bitte beachten Sie, dass einige Vorgänge nur von autorisierten Technikern durchgeführt werden dürfen.

Wenn ein hier nicht aufgeführter Fehler festgestellt wird, wenden Sie sich bitte an Ihren Händler.

6 Schnittstellen-Diagramm

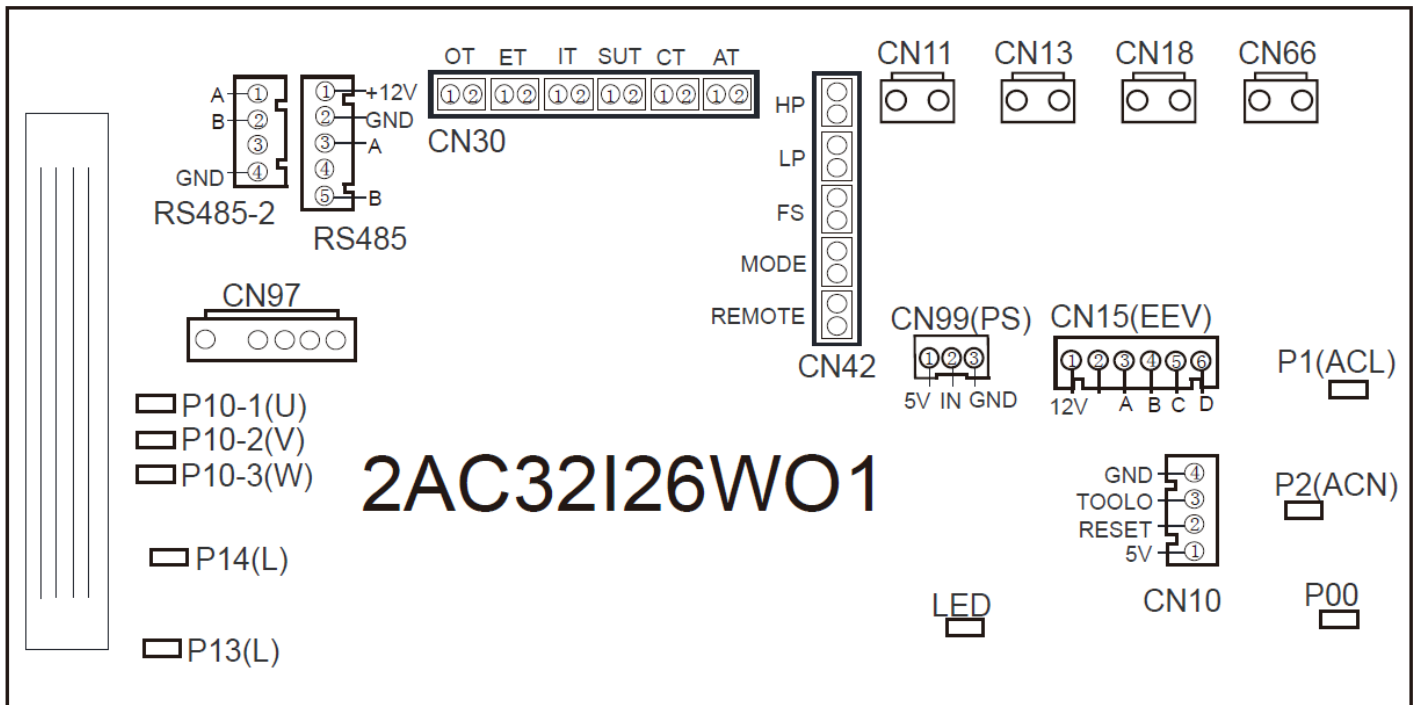
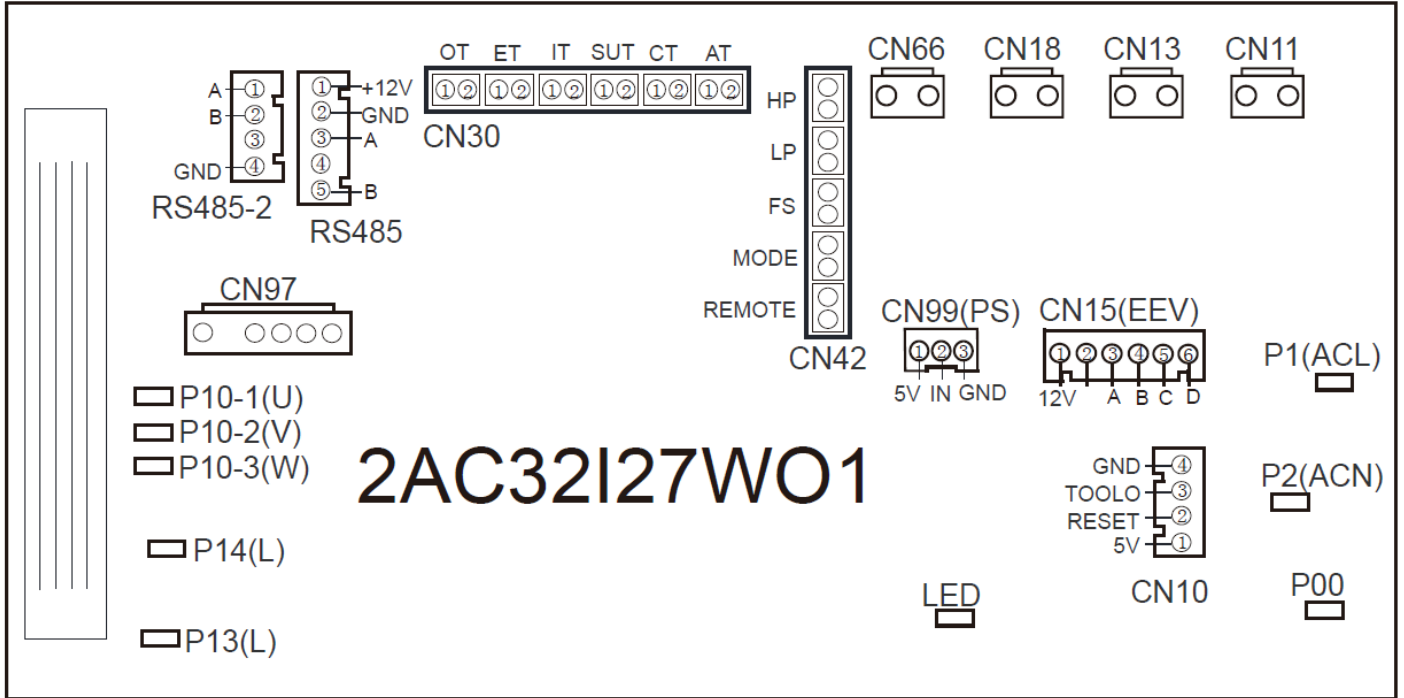

7 Schaltplan der Hauptplatine

Number	Sign	Meaning
01	P10-1/2/3(U/V/W)	Compressor
02	P13(L)	Resistance
03	P14(L)	Resistance
04	CN97	DC motor
05	RS485-2	The port for centralized control
06	RS485	Color line controller communication/WIFI
07	OT	Water output temperature
08	ET	System exhaust temperature
09	IT	Water input temperature
10	SUT	System suction temperature
11	CT	System fan coil temperature
12	AT	Ambient temperature
13	HP	System high pressure
14	LP	System low pressure
15	FS	Water flow switch
16	MODE	Mode switch
17	REMOTE	Emergency switch
18	CN66	Compressor signal
19	CN18	Water pump
20	CN13	Reserved
21	CN11	4-way valve
22	CN99	Low pressure sensor
23	CN15	Electronic expansion valve
24	P1	Live wire
25	P2	Neutral wire
26	CN10	Program port

8 WIFI-Modul Benutzerhandbuch



Laden Sie die Aquatemp-Anwendung herunter



Technische Parameter

BETRIEBSSPANNUNG: CD8V-12V (empfohlener Wert 12V) maximaler Verbrauch 1 A, durchschnittlicher Standby-Strom 50mA

TEMPERATURBEREICH: Betriebstemperatur: -30 - +70; Lagertemperatur: -40 -+85

LED-ANZEIGE: 4 Lichter, Netzwerkkonfigurationsanzeige, Router-Verbindungsanzeige, Cloud-Server-Verbindungsanzeige, 485-Kommunikationsanzeige;

ABMESSUNG (L×L×H) 78mm×63mm×24mm

Auf der Rückseite des WIFI-Moduls befindet sich ein Magnet, es kann im Innen- oder Außenbereich installiert werden, geschützt vor direkter Sonneneinstrahlung;

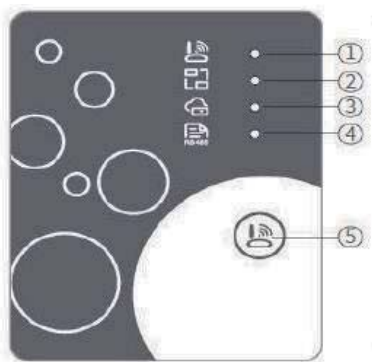

Licht	Bedeutung	Langes Licht	Blinkendes Licht	Off
1	Anzeige der Netzwerkkonfiguration	Netzwerk-Einstellung	Smart Link-Einstellung	Beendet
2	Anzeige der Routerverbindung	Normal	Abnormal	Off / In Bearbeitung
3	Anzeige für die Verbindung zum Cloud-Server	Normal	Abnormal	Off / In Bearbeitung
4	Anzeige für 485-Kommunikation	Normal	Abnormal	Off / In Bearbeitung
5	Konfigurationstaste, Einschalten	----	----	Kurz drücken

Login: Use the email address and password to register, login or reset the password.

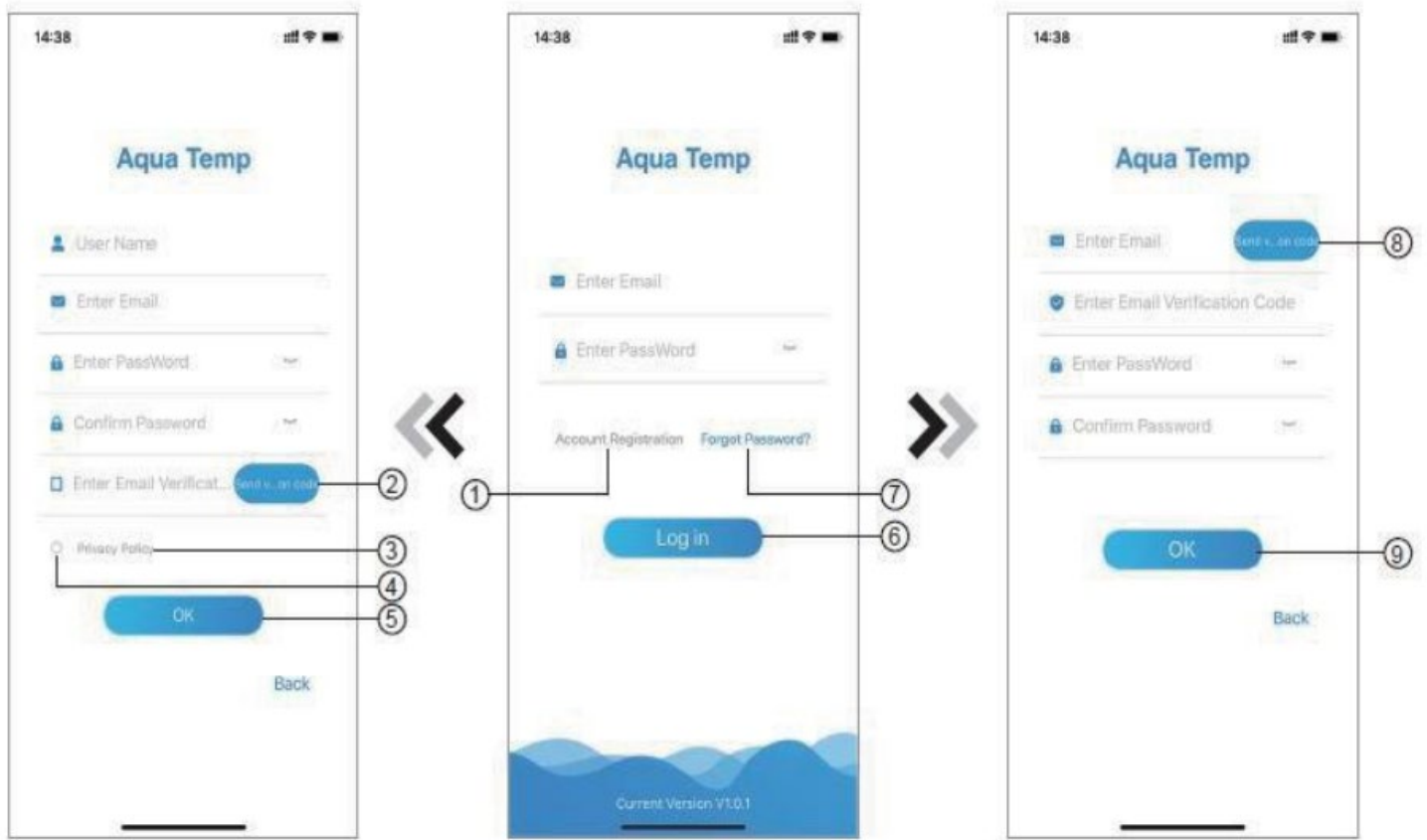

Registrierung eines Kontos: Um ein Konto zu registrieren, klicken Sie auf 1 (Abb.1), um die Schnittstelle zur Kontoregistrierung aufzurufen, geben Sie die Informationen ein und klicken Sie auf 2, um den Verifizierungscode zu erhalten. Bitte beachten Sie, dass die Gültigkeit eines Verifizierungscode 15 Minuten beträgt. Bitte geben Sie den Verifizierungscode innerhalb von 15 Minuten ein, andernfalls müssen Sie einen neuen Code anfordern.

Anmelden: Folgen Sie den Anweisungen auf der Seite (Abb.1), geben Sie die registrierte E-Mail-Adresse und das Passwort ein, klicken Sie auf und gehen Sie zur Geräteliste. Wenn Sie Ihr Passwort vergessen haben, klicken Sie auf Passwort vergessen und folgen Sie den Anweisungen.

Ein Gerät hinzufügen: Klicken Sie auf "Neues Gerät hinzufügen" und folgen Sie den Anweisungen, um das WIFI oder die DTU hinzuzufügen.

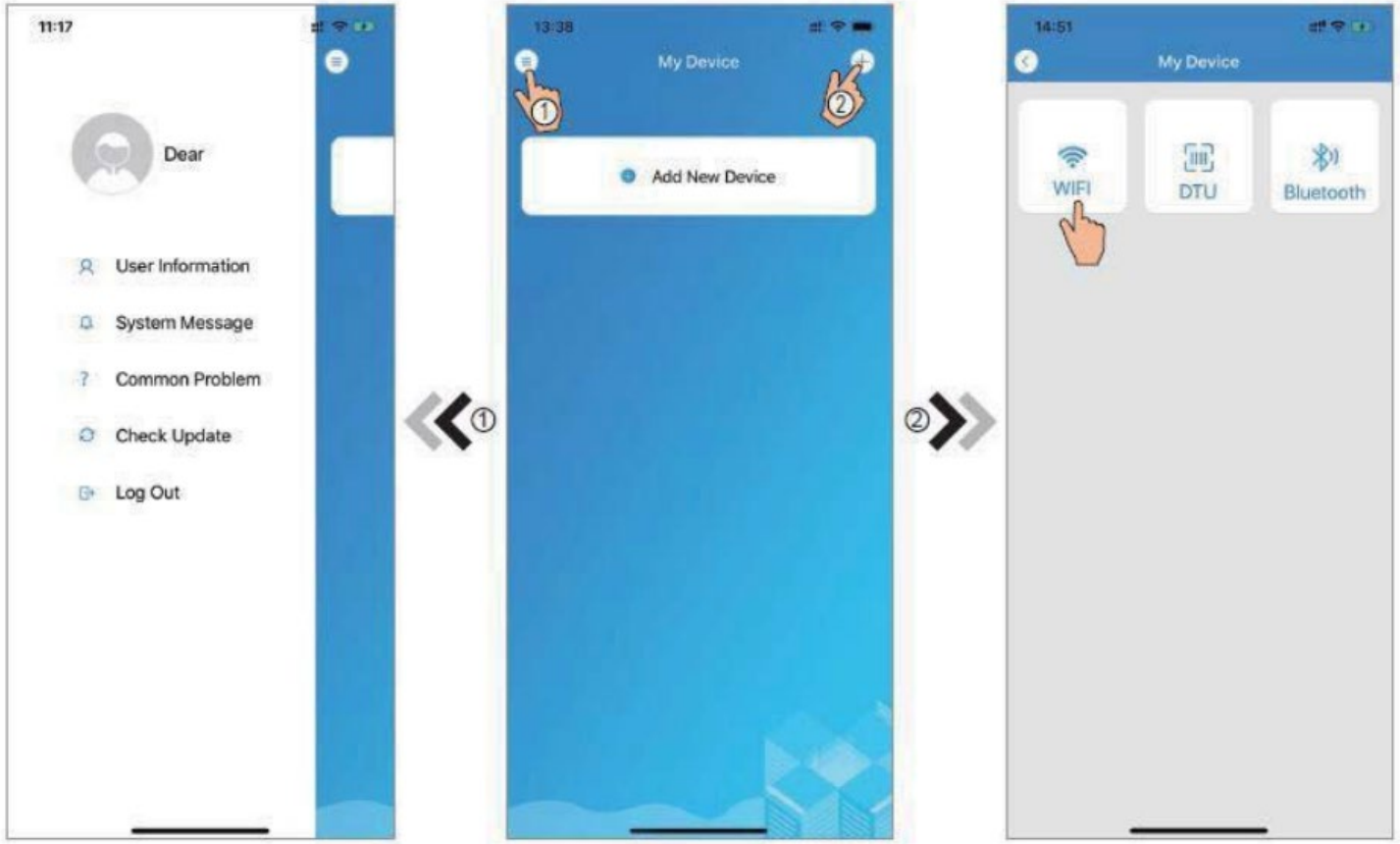

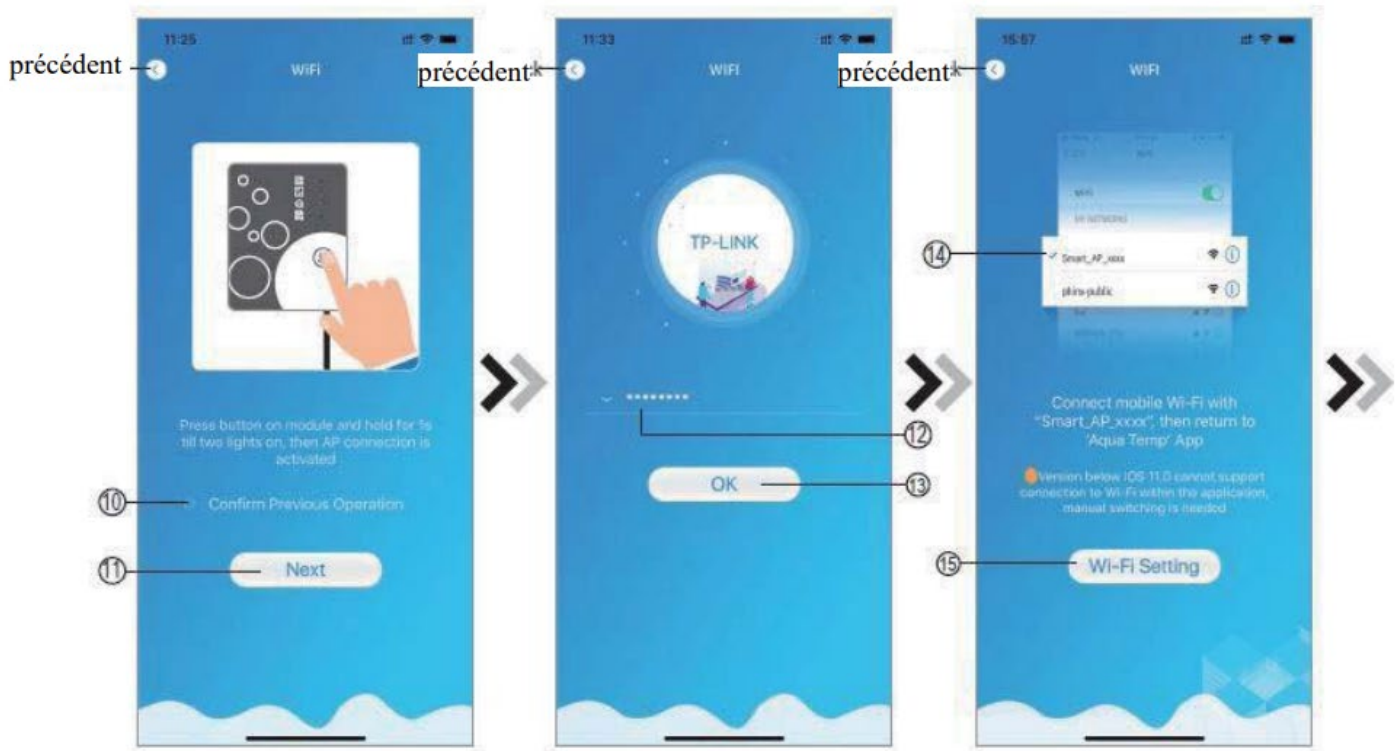

WiFi-Einstellung :

Folgen Sie den Anweisungen auf der Seite. Drücken und halten Sie die Taste auf dem Modul für 1 Sekunde, bis zwei Lichter aufleuchten. Klicken Sie zur Bestätigung auf 11, geben Sie das WiFi-Passwort ein, um die Verbindung herzustellen, und klicken Sie auf Bestätigen. Gehen Sie zu den Systemeinstellungen und verbinden Sie das angegebene WiFi, wählen Sie "Smart_ AP_ xxx", klicken Sie auf ok und folgen Sie den Anweisungen, um zur WiFi-Konfigurationsoberfläche zu gelangen..

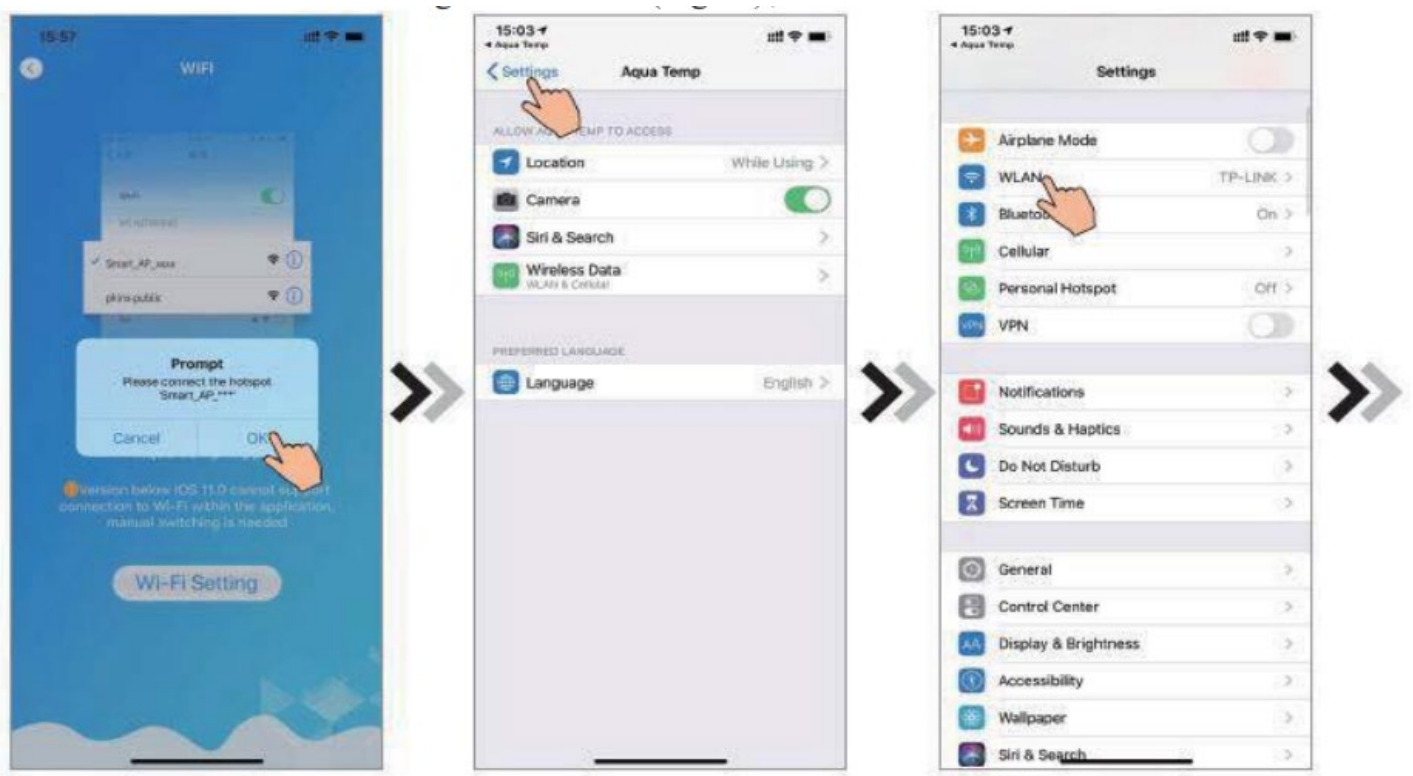

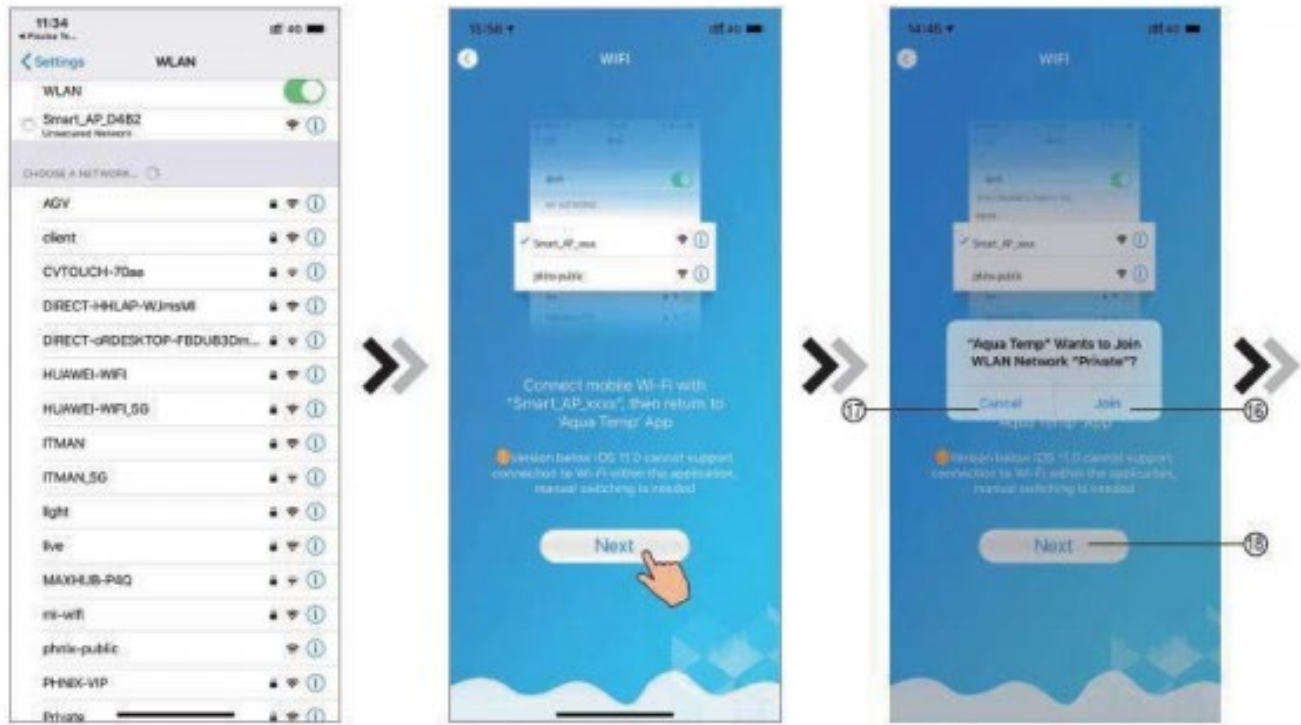

Geräteverwaltung: Sobald die WFI- und DTU-Verbindung hergestellt ist, kehren Sie zu Mein Gerät zurück.

Die Geräteverwaltungsvorgänge sind wie folgt:





	Name	Funktionen
	Aktivieren/Desaktivieren	Zum Aktivieren/Deaktivieren des Geräts anklicken
	Stiller Modus	Klicken Sie hier, um den Ruhemodus zu aktivieren
	Modus	Modus ändern: Heizen, Kühlen oder Auto
	Timer-Einstellungen	Klicken Sie hier, um die Schnittstelle zum Aktivieren/Deaktivieren und Stummschalten des Tons und des Timers aufzurufen
	Fehlersuche	Klicken Sie hier, um die Schnittstelle zur Fehlerbehebung aufzurufen
	Menü	Klicken Sie, um das Menü zu erweitern oder zu reduzieren

9 Garantie des Herstellers

Die Herstellergarantie beträgt 3 Jahre. Zusätzlich zu dieser Teilegarantie gewähren wir eine Arbeitsgarantie, die nur bei Rücksendungen an unsere Werkstätten inbegriffen ist. Wenn eine Rücksendung der Wärmepumpe vom Hersteller verlangt wird, gehen die Transportkosten für die Rücksendung in die Werkstatt zu Lasten des Kunden und die Kosten für die Rücksendung zum Standort des Kunden zu Lasten des Herstellers.

Diese Garantie gilt ausschließlich und anstelle jeder anderen stillschweigenden Garantie der Marktgängigkeit oder der Eignung für einen bestimmten Zweck sowie jeder anderen ausdrücklichen oder stillschweigenden Garantie. Die in dieser Garantie vorgesehenen Rechtsbehelfe sind ausschließlich und stellen die einzige Verpflichtung von Wärmepac dar, und jede andere von einer Person gemachte Zusicherung ist ohne Bedeutung.

10 Sicherheitshinweise



Berühren Sie den Ventilator nicht, während er läuft, da dies zu Verletzungen führen kann. Das Gerät sollte von Kindern ferngehalten werden,

Überprüfen Sie regelmäßig die Stromzufuhr und die Anschlusskabel Ihrer Wärmepumpe. Wenden Sie sich im Zweifelsfall an Ihren Installateur,

Im Falle eines Serviceeinsatzes müssen Sie die Originalteile des Herstellers verwenden.

Die Umgebung der Wärmepumpe muss immer sauber, gut belüftet und frei von jeglichen Elementen sein, die die Leistung des Geräts beeinträchtigen könnten.

Lassen Sie das gesamte Wasser aus dem Hydrauliksystem ab, um ein Einfrieren zu verhindern.

Stellen Sie das Gerät nicht in der Nähe von Wärmequellen oder brennbaren Materialien auf, da das Gerät ein Kältemittelgas enthält, das bei Kontakt mit einer Wärmequelle oder brennbaren Materialien zu einer Explosion führen kann. Rauchen Sie nicht in der Nähe des Geräts.

Wenn elektrische Bauteile ausgetauscht werden, müssen sie für den vorgesehenen Verwendungszweck geeignet sein und den richtigen Spezifikationen entsprechen. Die Wartungs- und Instandhaltungsanweisungen des Herstellers müssen stets befolgt werden. Im Zweifelsfall wenden Sie sich bitte an den technischen Kundendienst des Herstellers.

Bei Anlagen, die entflammbare Kältemittel verwenden, sollten die folgenden Kontrollen durchgeführt werden:

Die Größe der Füllung entspricht der Größe des Raums, in dem die kältemittelhaltigen Teile installiert sind;

Maschinen und Lüftungsauslässe funktionieren ordnungsgemäß und sind nicht verstopft; bei Verwendung eines indirekten Kältemittelkreislaufs muss der Sekundärkreislauf auf das Vorhandensein von Kältemittel überprüft werden; Kennzeichnungen an der Ausrüstung müssen sichtbar und lesbar bleiben. Unleserliche Markierungen und Schilder müssen korrigiert werden;

Kältemittelleitungen oder -bauteile sind so zu verlegen, dass sie nicht mit Stoffen in Berührung kommen, die die kältemittelhaltigen Bauteile angreifen könnten, es sei denn, die Bauteile sind aus inhärent korrosionsbeständigen Materialien hergestellt oder angemessen gegen eine solche Korrosion geschützt.

Lassen Sie Ihre Wärmepumpe regelmäßig von einem autorisierten Installateur überprüfen.

Am Ende seiner Lebensdauer müssen dieses Gerät und das darin enthaltene Gas recycelt werden. Wenden Sie sich bitte an Ihren Händler.



Guida all'installazione e all'uso

DC 35 / DC 55 / DC 75 / DC 95 / DC 115



1, avenue de Londres, 13127 Vitrolles, FRANCE

Tel: + 33 4 28 70 69 99

info@warmpac.fr

www.wpool.fr

Sarl au capital de 62 500 Euros - N° TVA intracommunautaire : FR 08519634851 - SIRET:519 634 851 00017 - Code APE : 4



Avvertenze



Prima dell'installazione, verificare le condizioni della pompa di calore ricevuta ed effettuare le consuete prenotazioni. In caso di dubbi o problemi, inviare una lettera AR all'installatore o contattare il produttore entro 48 ore. Dopo questo periodo, non è possibile accettare alcun reclamo.

Per offrire ai nostri clienti prodotti affidabili e di qualità, il prodotto è stato realizzato secondo rigorosi standard di fabbricazione e produzione.

Questo manuale contiene tutte le informazioni necessarie per l'installazione, la risoluzione dei problemi e la manutenzione dell'unità. Consultare il manuale prima di eseguire interventi di manutenzione o di utilizzo dell'unità.

L'installazione e la messa in funzione del dispositivo devono essere eseguite da personale specializzato e qualificato in conformità alle norme di sicurezza vigenti. Leggere attentamente le presenti istruzioni. Non ci assumiamo alcuna responsabilità per eventuali lesioni o danni alla macchina derivanti da errori di installazione. La mancata osservanza di queste istruzioni comporta la perdita della garanzia.

Utilizzare esclusivamente ricambi originali del produttore, pena la perdita della garanzia.

L'unità della pompa di calore deve essere utilizzata solo per riscaldare una piscina. Il suo utilizzo è riservato al riscaldamento e al mantenimento della temperatura di una piscina in condizioni predeterminate da una valutazione termica da effettuare con un rivenditore prima di scegliere la pompa di calore.



Questa pompa di calore rispetta le norme di fabbricazione e di comunicazione definite dal DTP10 della FPP e della NFPAC.

ATTENZIONE:

Non utilizzare alcun mezzo o procedimento per accelerare lo sbrinamento o la pulizia della pompa di calore. Non forare, non bruciare e non collocare in prossimità di una fonte di combustione. Il gas refrigerante non deve avere un odore forte.

Questo apparecchio non è destinato all'uso da parte di bambini o di persone con ridotte capacità fisiche o mentali senza supervisione, in quanto ciò potrebbe causare gravi lesioni o morte.

Il produttore e il distributore non sono responsabili per eventuali danni a cose e/o persone causati da un uso/installazione improprio.

L'installazione deve essere conforme agli standard elettrici locali e deve essere adeguatamente messa a terra. Il dispositivo deve essere scollegato dalla rete elettrica prima di qualsiasi intervento.

Direttiva 2002/96/CE (RAEE): il simbolo del bidone della spazzatura barrato sul fondo del dispositivo indica che questo prodotto, al termine della sua vita utile, deve essere smaltito separatamente dai rifiuti domestici, portato in un centro di riciclaggio per apparecchiature elettriche ed elettroniche o restituito al rivenditore quando si acquista un dispositivo equivalente.

Direttiva 2002/95/CE (RoHS): Questo prodotto è conforme alla Direttiva 2002/95/CE (RoHS) sulla restrizione dell'uso di sostanze nocive nelle apparecchiature elettriche ed elettroniche.

L'installazione di un interruttore automatico è necessaria per prevenire il rischio di incendi e scosse elettriche. Se l'alimentatore è danneggiato, farlo sostituire da un professionista per evitare lesioni personali e danni alle cose.

1. Dati tecnici

Riferimento		DC35	DC55	DC75	DC95	DC115
Capacità della piscina	Maxi	35m ³	55m ³	75m ³	95m ³	115m ³
Consumo di riscaldamento*	kW	1.4- 6.8	1.3- 7.93	1.75- 10.90	3.21-15.81	3.21- 17.05
Consumo*	kW	0.14- 1.51	0.12- 1.37	0.16- 1.96	0.31- 3.03	0.32- 3.98
COP *		10.0 -45	11.24-5.79	10.88- 5.56	10.3-5.22	10.01-4.82
* Test effettuato a 27°C di temperatura dell'aria, con la stessa differenza di temperatura e flusso d'acqua ottenuta a 15°C.						
Corrente nominale	A	1.02-5.18	0.9-6.0	1.2-8.6	1.5-13.3	2.0-17.5
Consumo di riscaldamento**	kW	1.1- 5.2	0.96 - 6.46	1.52- 8.21	2.3- 12.14	2.07- 15.20
Consumo**	kW	0.21- 1.24	0.19- 1.32	0.25- 1.84	0.37- 2.80	0.38- 3.60
** : Test effettuato a 15°C di temperatura dell'aria, con ingresso dell'acqua a 26°C e uscita dell'acqua a 28°C per definire la portata d'acqua, la capacità di riscaldamento e il consumo, secondo gli standard FPP.						
Consumo di energia a freddo***	kW	2.2	3.72	4.3	6.2	7.69
Consumo***	kW	1.4	1.45	1.78	3.3	2.66
COP***		1.55	2.57	2.43	1.86	2.89
*** Test eseguito a 35°C di temperatura dell'aria, con ingresso dell'acqua a 30°C e uscita dell'acqua a 29°C.						
Carrozzeria		ASA	ASA	ASA	ASA	ASA
Controllore		Ecran Digital tactile - Digital Touch screen				
Gaz		R32	R32	R32	R32	R32
Scambiatore		Titanio ritorto	Titanio ritorto	Titanio ritorto	Titanio ritorto	Titanio ritorto
Compressore		Panasonic Rotante	Panasonic Rotante	Panasonic Rotante	Panasonic Rotante	Panasonic Rotante
Unità di ventilazione		1	1	1	1	1
Velocità di rotazione della ventilazione	T/mn	400-700	400-750	400-800	300-750	400-750
Modo		Caldo/Freddo /Auto	Caldo/Freddo/ Auto	Caldo/Freddo /Auto	Caldo/Freddo/ Auto	Caldo/Freddo/ Auto
Campo di funzionamento		-7°C-43°C	-7°C-43°C	-7°C-43°C	-7°C-43°C	-7°C-43°C
Rumore (1m)	dB(A)	38-50	41-50	42-51	42-55	45-56
Alimentazione		Mono 220-240V/50HZ				

Regolatore		Elettronica	Elettronica	Elettronica	Elettronica	Elettronica
Flusso d'acqua	m ³ /H	2.5	2.7	3.5	5.2	5.6
Dimensione dell'unità	mm	1000/418/605	1000/418/605	1000/418/605	1046/453/767	1160/490/862
Dimensioni della confezione (l/L/h)	mm	1030/435/615	1030/435/615	1030/435/615	1130/480/780	1210/510/880
Nw/Gw	kg	43/54	47/58	51/62	66/79	74/88
Garanzia		3 anni	3 anni	3 anni	3 anni	3 anni

2. Dimensioni della pompa di calore

DC 35 - DC 55 - DC 75

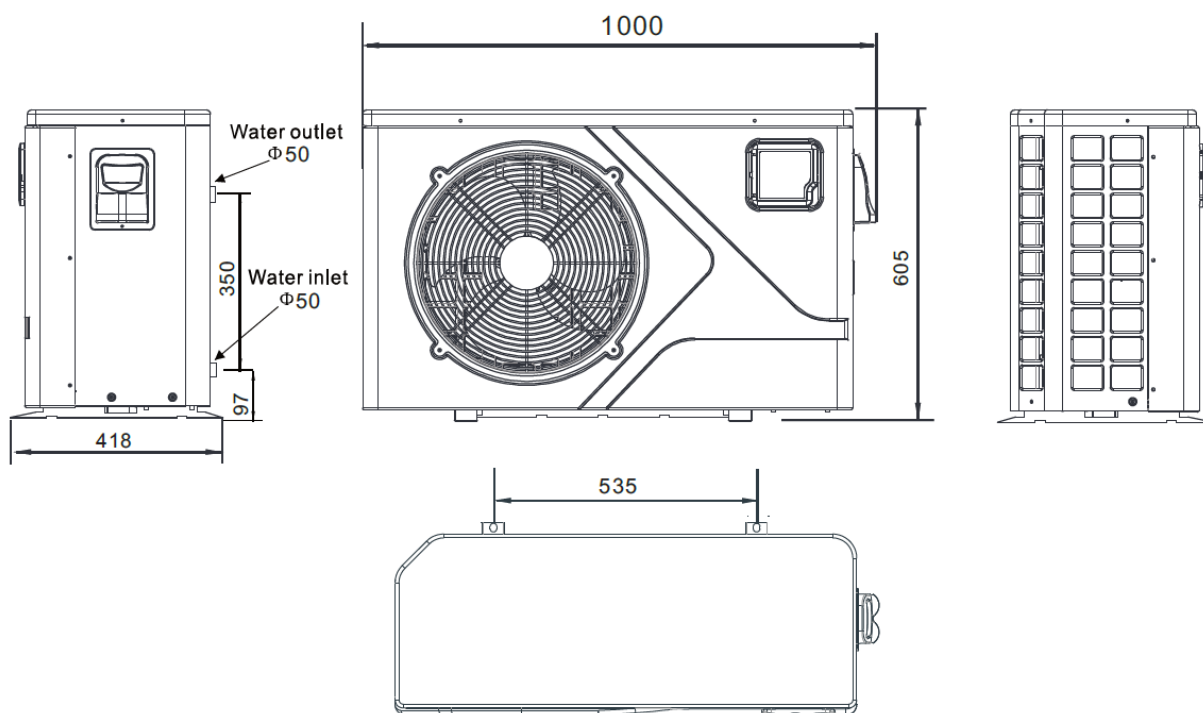

DC 95 :

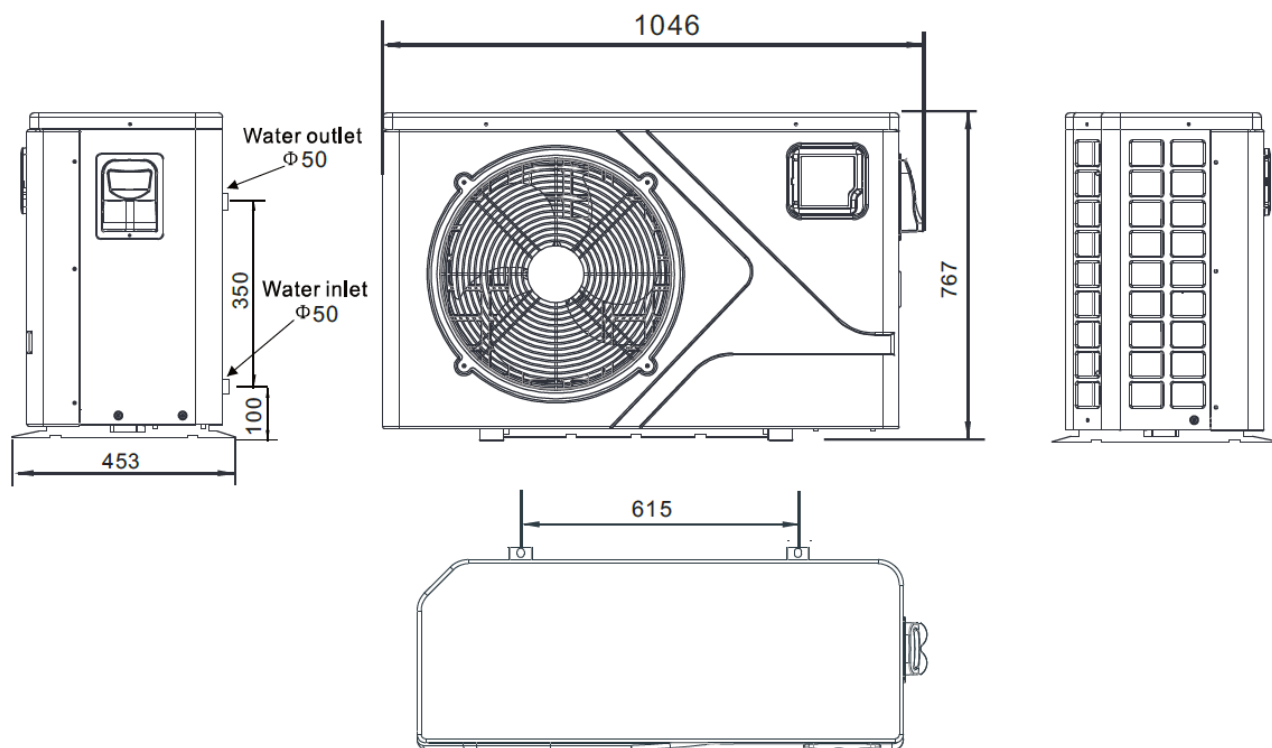

DC115

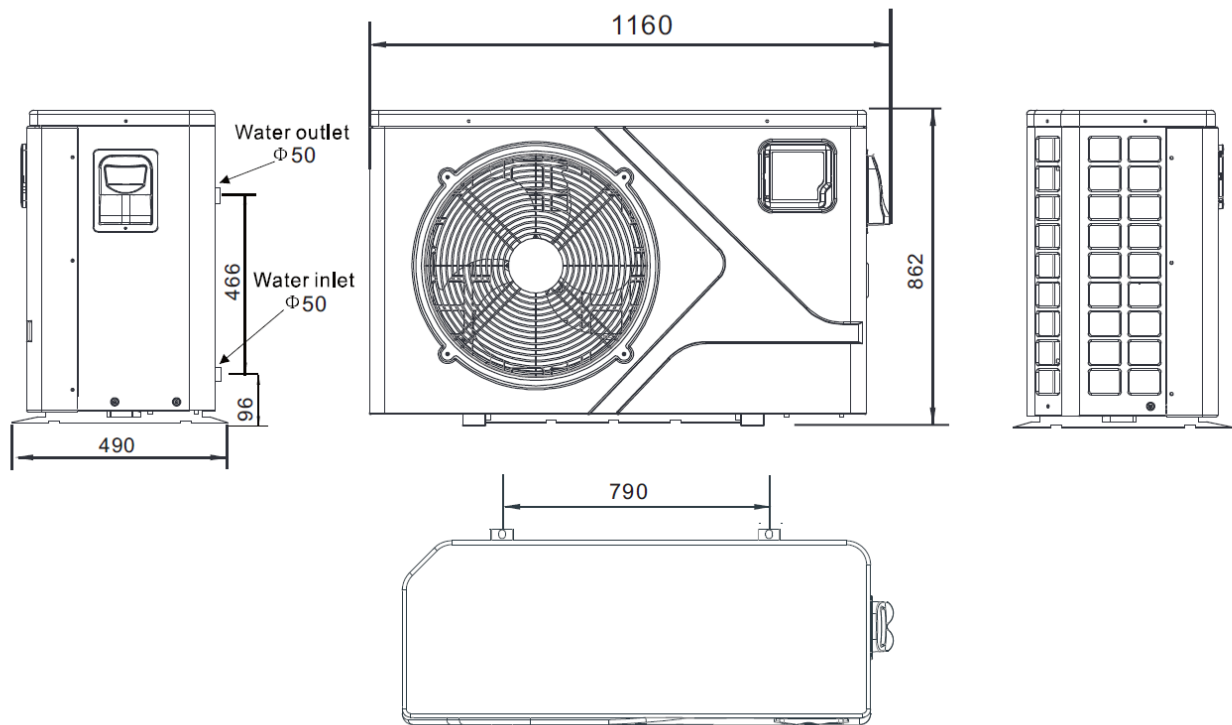

3. Installazione e collegamenti

Quando si usa la piscina per la prima volta, assicurarsi che la piscina sia piena d'acqua.

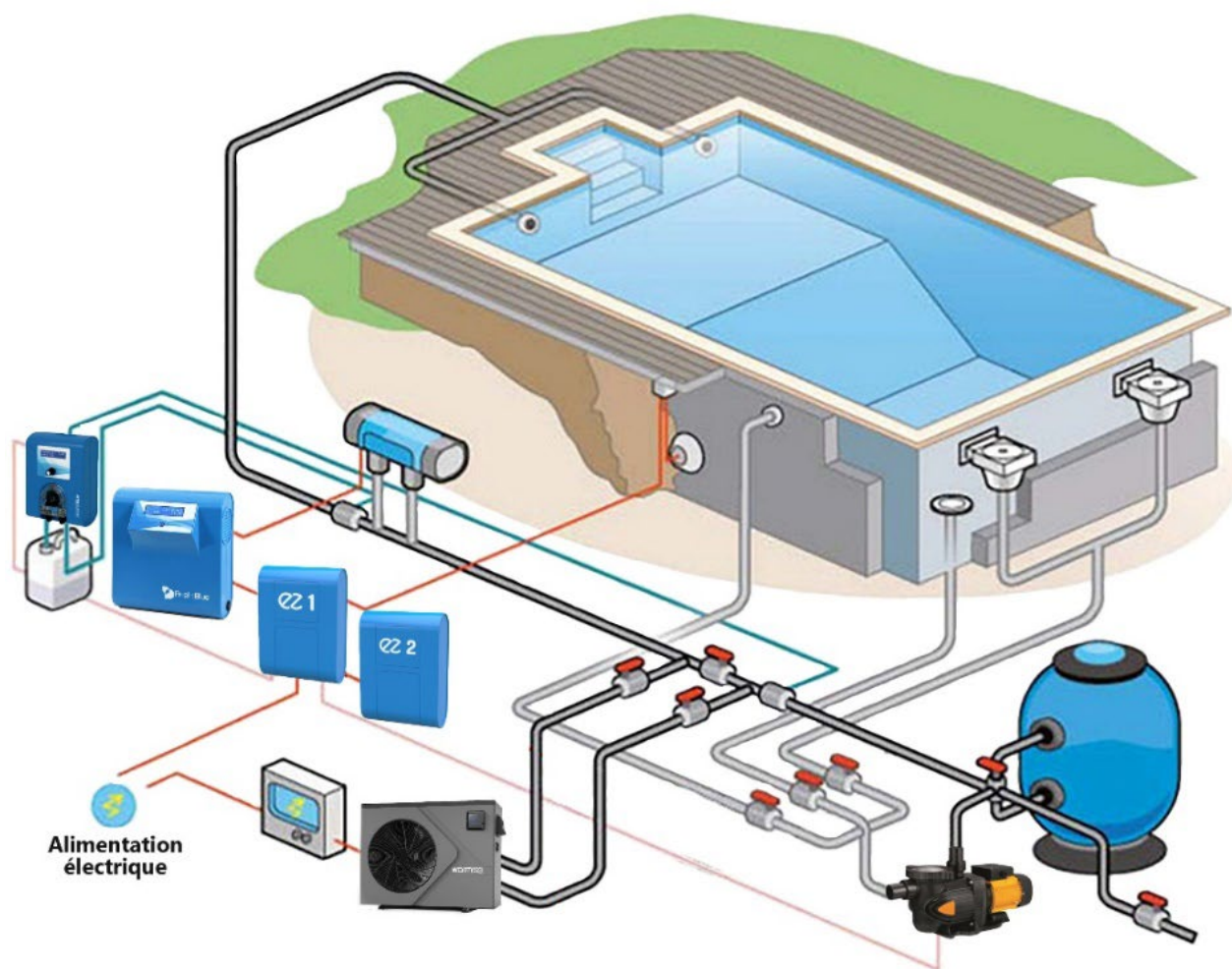



La scelta della vostra pompa di calore deve essere stata determinata da un bilancio termico personalizzato per essere certi che le sue caratteristiche corrispondano alle vostre esigenze. L'azienda non può in alcun modo essere ritenuta responsabile di prestazioni scadenti se il suo dimensionamento non è stato effettuato grazie a un bilancio termico personalizzato e se non sono state rispettate le condizioni di utilizzo indicate durante il bilancio termico.

La pompa di calore deve essere collocata all'esterno e deve rispettare le distanze minime di 3 m senza ostacoli davanti alla ventola - 50 cm dal muro per la parte posteriore e 15 cm dal suolo.

Si raccomanda di utilizzare borchie e di scaricare la condensa su una superficie impermeabile (che può essere ricoperta di ghiaia).

Se una di queste raccomandazioni non è applicata o applicabile, vi chiediamo di contattare il produttore per verificare se l'installazione effettuata o desiderata non influisca sul corretto funzionamento della vostra pompa di calore.

1.1 Collegamento idraulico

Lo scambiatore di calore in titanio a flusso esclusivo della pompa di calore per piscina non richiede particolari accorgimenti idraulici, ad eccezione del bypass. (Impostare la portata in base alla targhetta). La perdita di pressione dell'acqua è inferiore a 10kPa alla portata massima. Poiché non c'è calore residuo o temperatura di fiamma, l'unità non richiede tubazioni in rame per la dissipazione del calore. Il tubo in PVC può essere installato direttamente sull'unità.

Posizione: Collegare l'unità alla linea di mandata (ritorno) della pompa della piscina, a valle di tutte le pompe del filtro e della piscina e a monte di tutti i cloratori, ozonizzatori o pompe chimiche. Il modello standard è dotato di raccordi slip-on che accettano tubi in PVC da 32 o 50 mm per il collegamento alle tubature di filtrazione della piscina o della spa.

Si consiglia di aggiungere un raccordo a sgancio rapido all'ingresso e all'uscita dell'unità per consentire un facile svuotamento dell'unità per l'invernaggio e per facilitare l'accesso in caso di manutenzione.

Condensa: Poiché la pompa di calore raffredda l'aria di circa 4-5 gradi, l'acqua può condensare sulle alette dell'evaporatore. Se l'umidità relativa è molto alta, può raggiungere diversi litri all'ora. L'acqua scorre lungo le alette nella vaschetta di base e fuoriesce attraverso il raccordo di scarico della condensa in plastica spinato situato sul lato della vaschetta di base.

Questo raccordo è progettato per accogliere un tubo in vinile trasparente da 20 mm che può essere spinto a mano e indirizzato verso uno scarico appropriato. È facile confondere la condensa con le perdite d'acqua all'interno dell'unità.

Nota: un modo rapido per verificare che l'acqua sia condensa è spegnere l'unità e lasciare la pompa della piscina in funzione. Se l'acqua smette di uscire dalla piscina, si tratta di condensa.

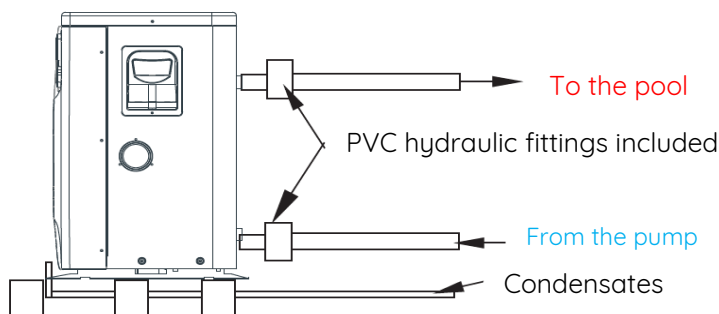

1.2 Collegamento elettrico



Importante: Il collegamento della pompa di calore deve essere eseguito da personale autorizzato e qualificato. Verificare che il cavo di alimentazione del locale tecnico abbia una sezione sufficientemente ampia per sostenere il consumo supplementare richiesto dalla macchina.

La pompa di calore deve essere alimentata da un interruttore automatico indipendente con curva D che può trovarsi sul quadro elettrico principale dotato di differenziale o su un pannello indipendente collegato al quadro principale, che avrà un differenziale. In caso contrario, aggiungere un differenziale al quadro indipendente della pompa di calore.

Riferimento	Alimentazione	Potenza dell'interruttore D-Curve	Sezione del cavo in base alla distanza tra l'interruttore automatico e la pompa di calore		
			- 10 m	10 -15 m	+ 15 m
DC 35	Monofasico 230 V	16 Ampere	3G2.5 mm ²	3G2.5 mm ²	3G6 mm ²
DC 55	Monofasico 230 V	16 Ampere	3G2.5 mm ²	3G2.5 mm ²	3G6 mm ²
DC 75	Monofasico 230 V	20 Ampere	3G2.5 mm ²	3G2.5 mm ²	3G6 mm ²
DC 95	Monofasico 230 V	25 Ampere	3G2.5 mm ²	3G2.5 mm ²	3G6 mm ²
DC 115	Monofasico 230 V	25 Ampere	3G2.5 mm ²	3G2.5 mm ²	3G6 mm ²

Collegamento elettrico sulla morsettieria della pompa di calore

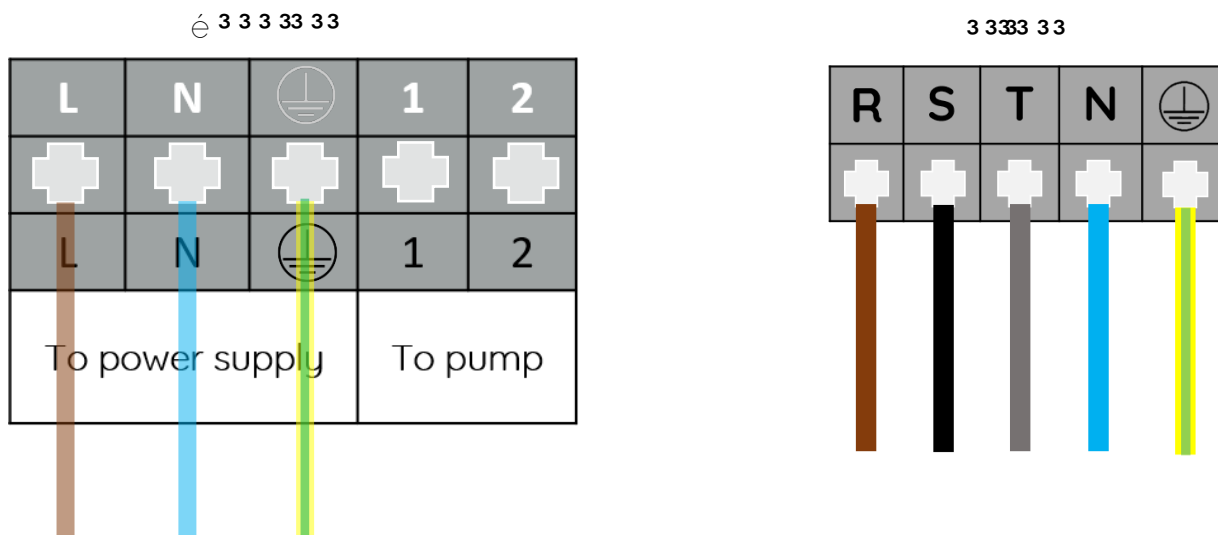

Svitare la maniglia per accedere al collegamento elettrico.

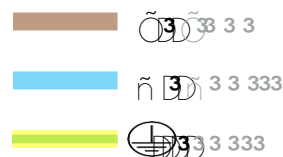

4. Commissione

Dopo aver installato correttamente la pompa di calore sul circuito idraulico della piscina o della spa, la pompa di filtrazione della piscina deve essere in funzione per far circolare l'acqua nello scambiatore di calore della pompa di calore.

- 1: Assicurarsi che le valvole della pompa di calore siano impostate correttamente: By Pass: aperta al 50%, valvola di ingresso: aperta al 100%, valvola di uscita: aperta al 70%.
- 2: Accendere la pompa di filtrazione e verificare che non vi siano perdite nel circuito idraulico e che l'acqua circoli correttamente attraverso gli ugelli di scarico della piscina o della spa.
- 3: Collegare l'alimentazione e premere il pulsante ON/OFF sul telecomando. Se l'installazione è stata eseguita correttamente, la pompa di calore dovrebbe accendersi immediatamente.
- 4: Dopo qualche minuto, l'aria rilasciata dal ventilatore dovrebbe essere significativamente più fredda dell'aria ambiente.
- 5: Quando la pompa di calore è in funzione, spegnere la pompa di filtraggio e l'unità dovrebbe fermarsi.
- 6: Far funzionare la pompa di filtrazione e la pompa di calore 24 ore su 24 fino al raggiungimento della temperatura desiderata. Quando la temperatura desiderata viene raggiunta, l'unità rallenta, quando la temperatura viene mantenuta per 45 minuti e ; l'unità si arresta e si riavvia automaticamente non appena la temperatura dell'acqua è inferiore di 0,2 °C rispetto alla temperatura impostata richiesta (attenzione: la pompa di filtrazione deve essere in funzione perché la pompa di calore funzioni).

5. Guida al telecomando

5.1 Presentazione generale

La pompa di calore è dotata di un comando digitale a sfioramento programmato in fabbrica in modalità calda.

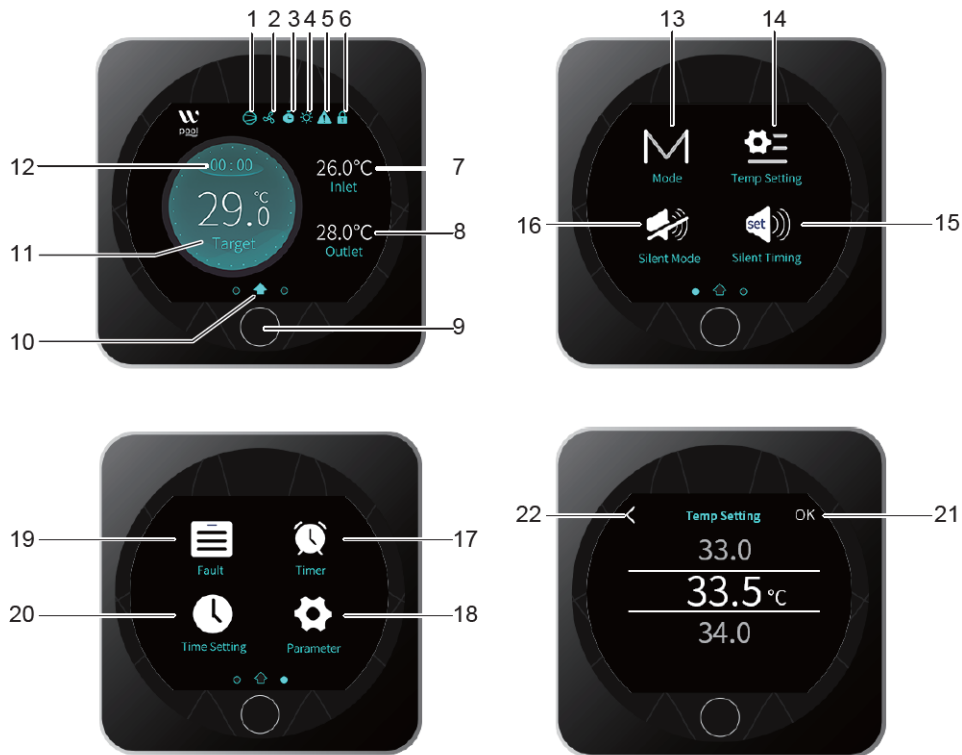

- 1: Indicatore di funzionamento del compressore
- 2: Ventilazione
- 3: Timer
- 4 : Modalità di controllo della temperatura: caldo - freddo - automatico
- 5 : Allarme
- 6 : Blocco del display
- 7 : Temperatura di ingresso dell'acqua
- 8 : Temperatura di uscita dell'acqua
- 9 : Accensione/spegnimento/ritorno
- 10 : Schermata principale
- 11: Temperatura nominale
- 12: Tempo del sistema
- 13: Modalità di funzionamento
- 14: Modifica della temperatura nominale
- 15: Impostazioni della modalità silenziosa
- 16: Attivazione della modalità silenziosa
- 17: Programmazione dell'ora
- 18: Parametri avanzati
- 19: Elenco dei codici di errore
- 20 : Impostazione di data e ora

21 : Conferma

22 Indietro (ATTENZIONE le impostazioni che si stanno modificando non verranno salvate.21 : Confirm



OFF :

Quando la pompa di calore è in modalità standby, sul display appare la scritta OFF. Dopo un po' di tempo, il display si spegne e passa in standby.

ON :

Quando la pompa di calore è in funzione, il display diventa blu.

Per passare da una modalità all'altra, premere il pulsante nero centrale per 0,5

5.2 Impostazione della data e dell'ora

La data e l'ora possono essere impostate in modalità ON o OFF.



Premere una volta il pulsante centrale per tornare alla schermata principale.

5.3 Impostazione del programma orario

Questa funzione deve essere programmata se si desidera programmare gli orari di funzionamento della pompa di calore (ATTENZIONE: la pompa di filtrazione della piscina deve essere in funzione per poter avviare la pompa di calore). È possibile programmare un orario di avvio e un orario di arresto per la pompa di calore.



Blu : Attivo

Grigio : Inattivo

Premere due volte il pulsante centrale per tornare alla schermata principale.

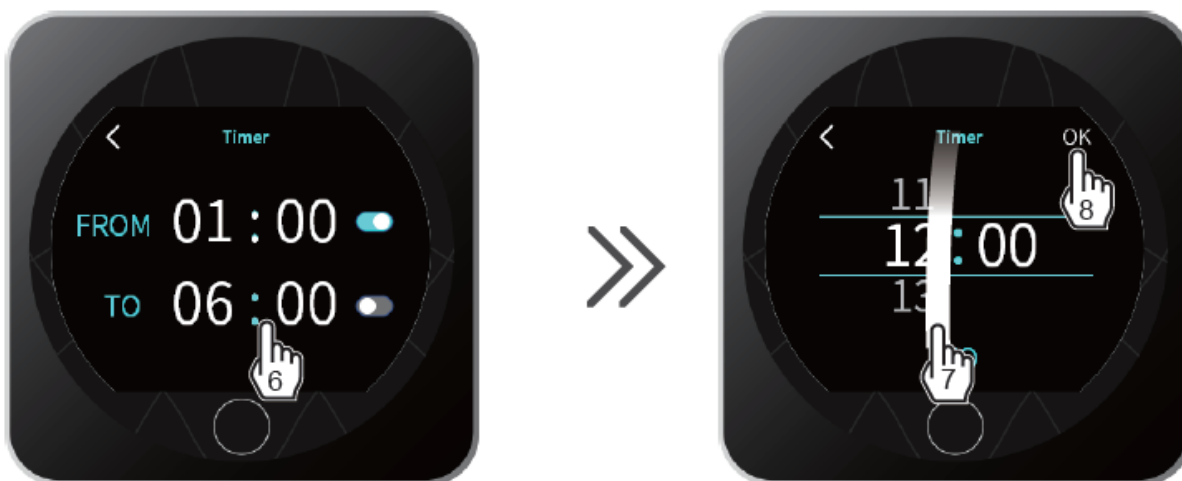

5.3 Regolazione della temperatura nominale

La temperatura di setpoint può essere modificata in modalità ON o OFF con una precisione di 0,5°C.



Premere una volta il pulsante centrale per tornare alla schermata principale.



Premere una volta il pulsante centrale per tornare alla schermata principale.

5.5 Selezione della modalità di temperatura



Premere una volta il pulsante centrale per tornare alla schermata principale.

5.6 Selezione della modalità di temperatura

Lo schermo può essere bloccato o sbloccato in modalità ON o OFF.



Premere una volta il pulsante centrale per tornare alla schermata principale.

5.7 Impostazione della modalità silenziosa

La modalità Silent consente alla pompa di calore di funzionare in modo molto economico e silenzioso quando il fabbisogno di riscaldamento è basso (necessità di mantenere la temperatura solo in condizioni climatiche molto favorevoli o necessità specifiche di un funzionamento ultra silenzioso).

Attivazione / Disattivazione



Silenzio attivato



Silenzio inattivato



Premere una volta per tornare alla schermata principale



Premere due volte il pulsante centrale per tornare alla schermata principale. Una volta attivata, l'impostazione è attiva per 7 giorni alla settimana..

5.8 Risoluzione dei problemi/codici di errore

Si noti che alcune operazioni devono essere eseguite da tecnici autorizzati.

Se la pompa di calore rileva un errore, nella parte superiore dello schermo appare un piccolo triangolo come segue:

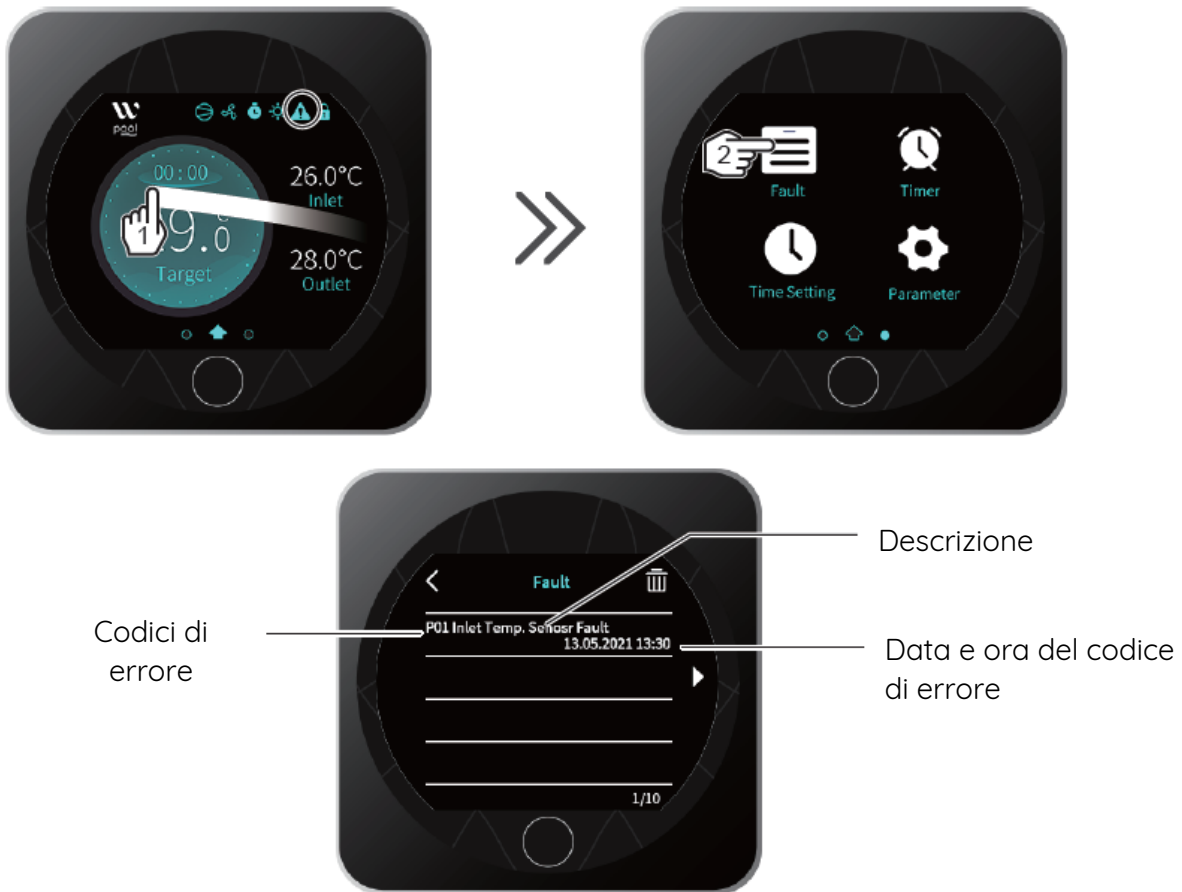

Quando il problema è risolto, l'errore scompare da solo e scompare anche il simbolo dell'errore.

Per eliminare l'elenco degli errori, fare clic sul simbolo del cestino.

Premete due volte il pulsante centrale per tornare alla schermata principale.

5.9 Elenco dei parametri e dei codici di errore

Errore / Guasto	Code	Motivo	Metodo di risoluzione
Guasto del sensore della temperatura dell'acqua in ingresso	P01	La sonda è danneggiata o in cortocircuito	Controllare o sostituire la sonda
Guasto al sensore della temperatura di uscita dell'acqua	P02	La sonda è danneggiata o in cortocircuito	Controllare o sostituire la sonda
Guasto del sensore della temperatura ambiente	P04	La sonda è danneggiata o in cortocircuito	Controllare o sostituire la sonda
Guasto del sensore di temperatura dello scambiatore di calore 1	P05	La sonda è danneggiata o in cortocircuito	Controllare o sostituire la sonda
Guasto sensore di temperatura scambiatore 2	P15	La sonda è danneggiata o in cortocircuito	Controllare o sostituire la sonda
Guasto sensore di temperatura SUT	P07	La sonda è danneggiata o in cortocircuito	Controllare o sostituire la sonda
Guasto sonda di temperatura ET	P081	La sonda è danneggiata o in cortocircuito	Controllare o sostituire la sonda
Guasto sonda ET (protezione)	P 082	Sovraccarico del compressore	Controllare se l'impianto e il compressore funzionano correttamente
Guasto sonda temperatura antigelo	P 09	La sonda è danneggiata o in cortocircuito	Controllare o cambiare la sonda
Guasto sensore di pressione	PP	La sonda è danneggiata o in cortocircuito	Controllare o cambiare la sonda
Alta pressione del compressore	E 01	Rilevato problema di pressione del compressore	Controllare le impostazioni delle valvole (By Pass aperto al 70% - Valvola di ingresso dell'acqua aperta al 100% e valvola di uscita dell'acqua aperta al 70%). Controllare il sensore di pressione e il sensore di flusso.
Bassa pressione del compressore	E 02	Rilevato problema alla pressione del compressore	Controllare e/o sostituire il sensore di pressione e contattare l'installatore per controllare il circuito del refrigerante.
Interruttore di flusso dell'acqua	E 03	Rilevato errore del sensore di flusso	Controllare la circolazione dell'acqua nel circuito idraulico, se la pompa di filtrazione non è accesa la pompa di calore non funziona. Controllare le impostazioni delle valvole (By Pass aperto al 70% - Valvola di ingresso dell'acqua aperta al 100% e valvola di uscita dell'acqua aperta al 70%). Controllare e/o sostituire il sensore di flusso

Protezione da bassa temperatura	E 05	La temperatura ambiente o dell'acqua è troppo bassa	Controllare le temperature dell'acqua e dell'ambiente
Distanza tra ingresso e uscita dell'acqua	E 06	Il flusso d'acqua non è sufficiente	Controllare la circolazione dell'acqua e le impostazioni delle valvole (By Pass aperto 70% - Valvola di ingresso dell'acqua aperta al 100% e valvola di uscita dell'acqua aperta al 70%).
Protezione antigelo	E 07	Il flusso d'acqua non è sufficiente	Controllare la circolazione dell'acqua e le impostazioni delle valvole (By Pass aperto 70% - Valvola di ingresso dell'acqua aperta al 100% e valvola di uscita dell'acqua aperta al 70%).
Protezione antigelo primaria	E 19	La temperatura ambiente è troppo bassa	Controllare il sensore di temperatura ambiente
Protezione antigelo secondaria	E 29	La temperatura ambiente è troppo bassa	Controllare il sensore della temperatura ambiente
Protezione da sovraccarico del compressore	E 051	Il compressore è sovraccarico	Controllare se il sistema e il compressore funzionano normalmente.
Guasto di comunicazione	E 08	Mancanza di comunicazione tra controllo e scheda madre	Controllare il collegamento tra il controllo e la scheda madre
Guasto di comunicazione (modulo di controllo della velocità)	E 081	Il modulo di controllo della velocità e l'unità di controllo non comunicano	Controllare il collegamento
Temperatura ambiente troppo bassa	TP	Temperatura ambiente troppo bassa	Controllare se il motore del ventilatore è rotto o bloccato.
Guasto rilevato nel sistema di ventilazione	F 051	È stato rilevato un problema nel motore del ventilatore	Sostituire il motore del ventilatore
Guasto al motore del ventilatore	F 031 F 032	Il motore del ventilatore è bloccato, il collegamento non sembra funzionare normalmente	Controllare il collegamento

Si noti che alcune operazioni devono essere eseguite da tecnici autorizzati.

Se viene rilevato un errore non elencato qui, contattare il proprio rivenditore.

6 Diagramma di interfaccia

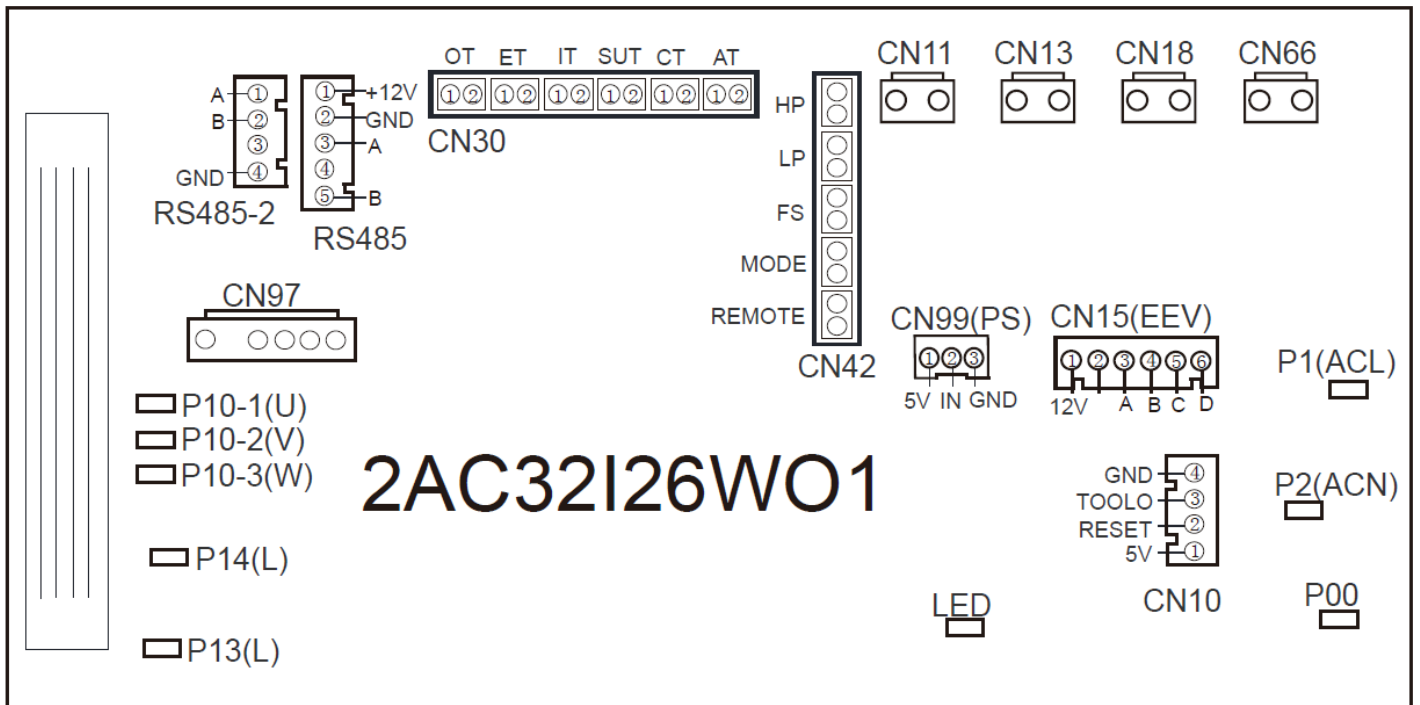
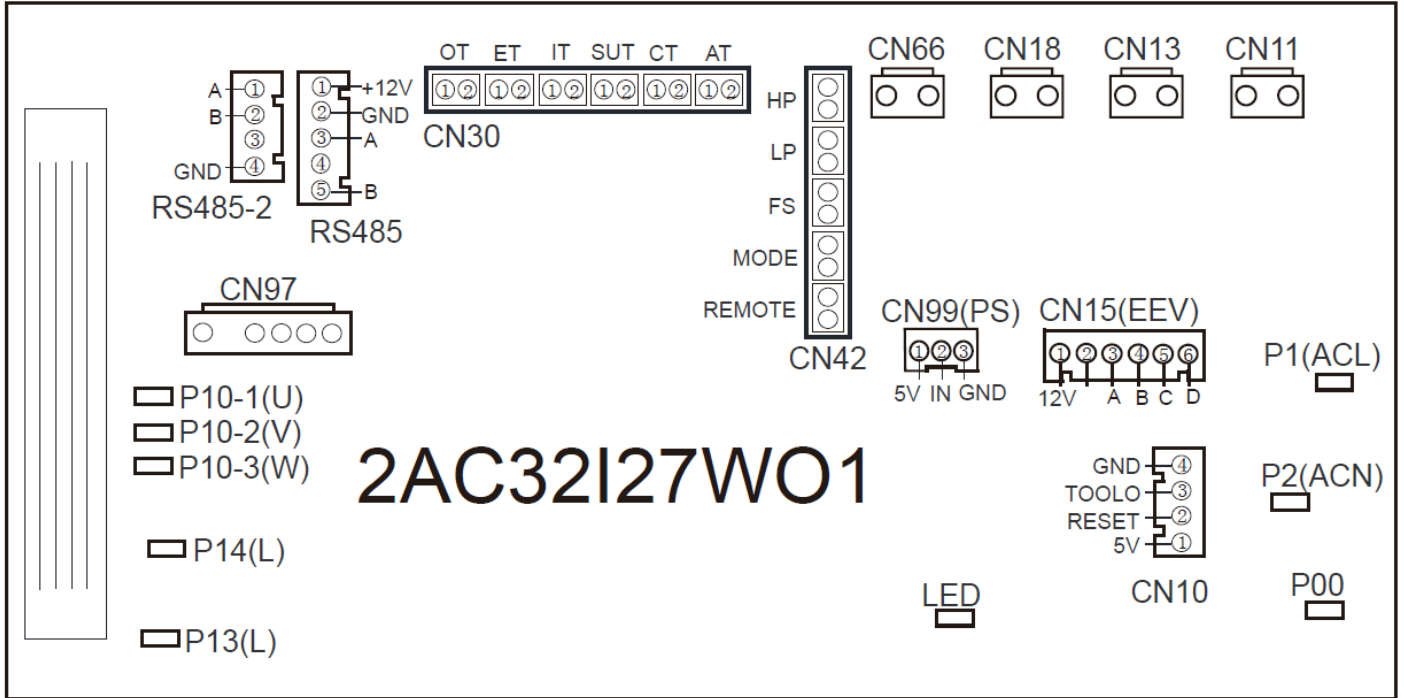

7 Schema della scheda madre

Number	Sign	Meaning
01	P10-1/2/3(U/V/W)	Compressor
02	P13(L)	Resistance
03	P14(L)	Resistance
04	CN97	DC motor
05	RS485-2	The port for centralized control
06	RS485	Color line controller communication/WIFI
07	OT	Water output temperature
08	ET	System exhaust temperature
09	IT	Water input temperature
10	SUT	System suction temperature
11	CT	System fan coil temperature
12	AT	Ambient temperature
13	HP	System high pressure
14	LP	System low pressure
15	FS	Water flow switch
16	MODE	Mode switch
17	REMOTE	Emergency switch
18	CN66	Compressor signal
19	CN18	Water pump
20	CN13	Reserved
21	CN11	4-way valve
22	CN99	Low pressure sensor
23	CN15	Electronic expansion valve
24	P1	Live wire
25	P2	Neutral wire
26	CN10	Program port

8 Manuale d'uso del modulo WIFI



Scaricare l'applicazione Aquatemp



Parametri tecnici

TENSIONE DI FUNZIONAMENTO: CD8V-12V (valore consigliato 12V) consumo massimo 1 A, corrente media di standby 50mA

CAMPO DI TEMPERATURA: Temperatura di funzionamento: -30 ~ +70; Temperatura di stoccaggio: -40 ~+85

INDICATORE LED: 4 luci, indicatore di configurazione della rete, indicatore di connessione al router, indicatore di connessione al server cloud, indicatore di comunicazione 485;

DIMENSIONE (LxLxH): 78mmx63mmx24mm

Sul retro del modulo WIFI è presente un magnete; può essere installato all'interno o all'esterno, al riparo dalla luce solare diretta;

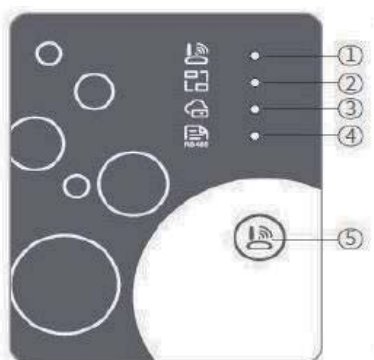

Luce	Significato	Luce lunga	Luce lampeggiante	Off
1	Indicatore di configurazione di rete	Network setting	Impostazione Smart Link	Finished
2	Indicatore di connessione al router	Normal	Anormale	FinitoSpento / In corso
3	Indicatore di connessione al server cloud	Normal	Anormale	FinitoSpento / In corso
4	Indicatore di comunicazione 485	Normal	Anormale	FinitoSpento / In corso
5	Pulsante di configurazione, accensione	----	----	Premere brevemente

Accesso: Utilizzare l'indirizzo e-mail e la password per registrarsi, effettuare il login o reimpostare la password.

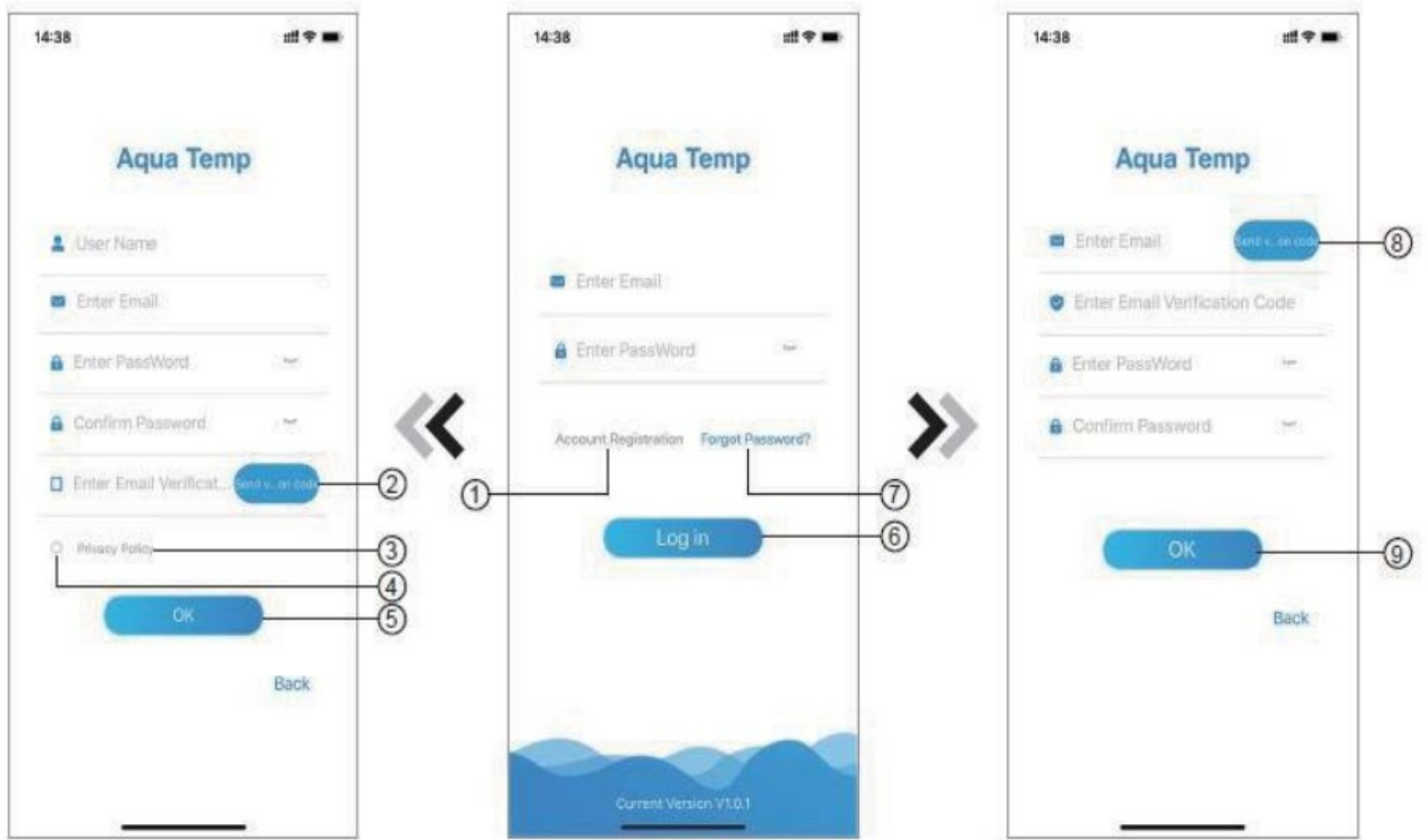

Registrazione dell'account: Per registrare un account, fare clic su 1 (Fig.1) per accedere all'interfaccia di registrazione dell'account, compilare le informazioni e fare clic su 2 per ricevere il codice di verifica; mentre si compilano le informazioni richieste, fare clic su 3 per leggere i dettagli dell'informativa sulla privacy, fare clic su 4 per accettare e fare clic su 5, la registrazione è completa. Si prega di notare che la validità del codice di verifica è di 15 minuti; si prega di compilare il codice di verifica entro 15 minuti, altrimenti sarà necessario richiederne uno nuovo.

Accesso: Seguire le istruzioni della pagina (Fig.1), inserire l'indirizzo e-mail e la password registrati, fare clic e accedere all'elenco dei dispositivi. Se si è dimenticata la password, cliccare su Password dimenticata e seguire le istruzioni.

Aggiungere un dispositivo: Fare clic su Aggiungi un nuovo dispositivo e seguire le istruzioni per aggiungere il WIFI o la DTU.

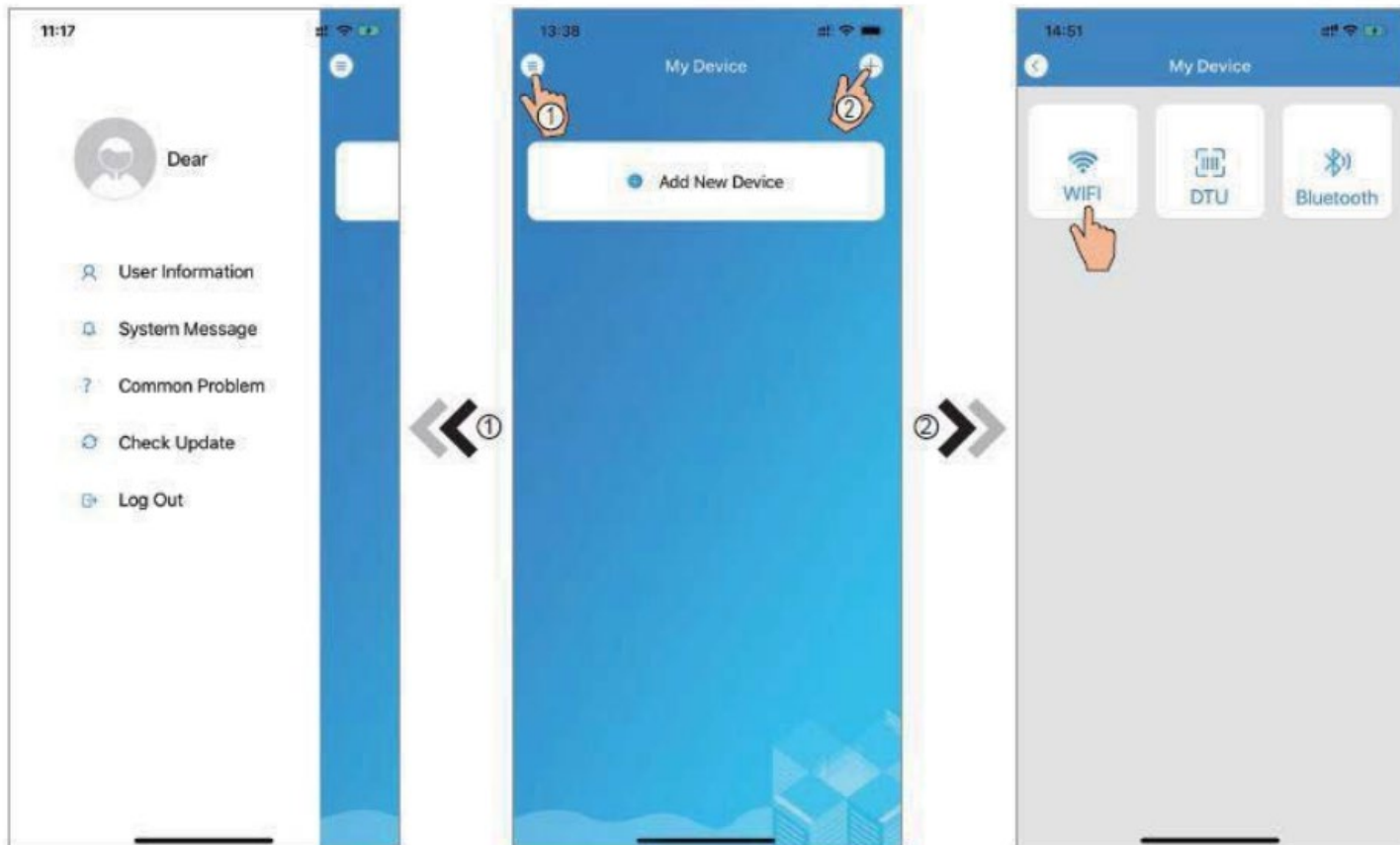

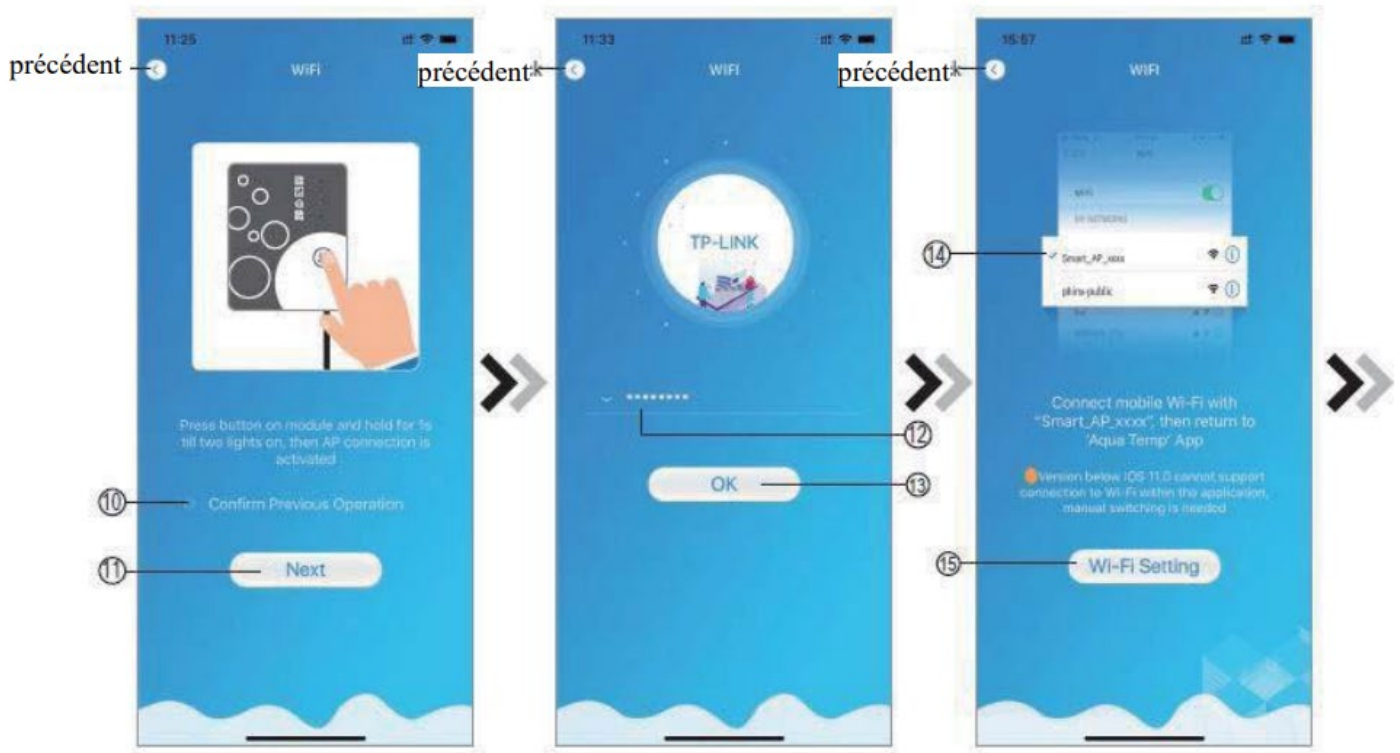

Impostazione WIFI :

Seguire le istruzioni riportate nella pagina. Tenere premuto il pulsante del modulo per 1 secondo finché non si accendono due spie. Cliccare su 11 per confermare, inserire la password WIFI per stabilire la connessione e cliccare su conferma. Accedere alle impostazioni del sistema e collegare il WIFI specificato, selezionare "Smart_ AP_ xxx", fare clic su OK e seguire le istruzioni per accedere all'interfaccia di configurazione WIFI.



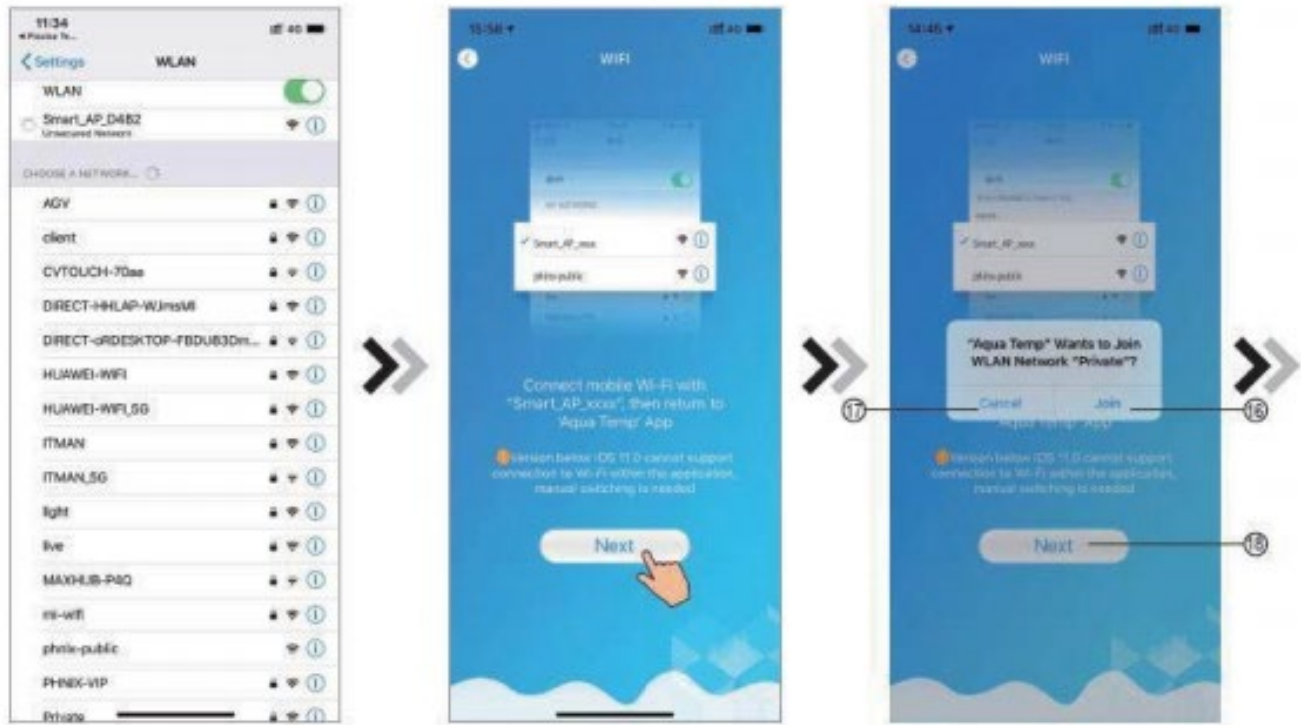

Gestione del dispositivo: Una volta completata la connessione WFI e DTU, tornare a Il mio dispositivo.

Le operazioni di gestione del dispositivo sono le seguenti:





	Nome	Funzioni
	Attivare/Disattivare	Fare clic per attivare/disattivare il dispositivo
	Modalità silenzio	Fare clic qui per attivare la modalità silenzio
	Modalità	Cambiare modalità: Caldo, Fresco o Auto
	Impostazioni del timer	Fare clic per accedere all'interfaccia per attivare/disattivare e silenziare il suono e il timer
	Risoluzione dei problemi	Fare clic per accedere all'interfaccia di risoluzione dei problemi
	Menu	Fare clic per espandere o chiudere il menu

9 Garanzia del produttore

La garanzia del produttore è di 3 anni. Oltre a questa garanzia sui pezzi di ricambio, forniamo anche una garanzia sulla manodopera, che è inclusa solo in caso di restituzione presso le nostre officine. Se il produttore richiede la restituzione della pompa di calore, le spese di trasporto per la restituzione all'officina sono a carico del cliente e le spese di restituzione alla sede del cliente sono a carico del produttore.

La presente garanzia è esclusiva e sostituisce qualsiasi altra garanzia implicita di commerciabilità o idoneità a uno scopo particolare e qualsiasi altra garanzia esplicita o implicita. I rimedi previsti dalla presente garanzia sono esclusivi e costituiscono l'unico obbligo di Warmpac e qualsiasi altra dichiarazione fatta da qualsiasi persona non avrà alcuna conseguenza.

10 Consigli per la sicurezza



Non toccare il ventilatore mentre è in funzione, per non incorrere in lesioni. L'unità deve essere tenuta lontana dai bambini,

Controllare regolarmente l'alimentazione e i cavi di collegamento della pompa di calore. In caso di dubbi, contattare l'installatore,

In caso di intervento di assistenza, è necessario utilizzare i ricambi originali del produttore.

L'ambiente intorno alla pompa di calore deve essere sempre pulito, adeguatamente ventilato e privo di elementi che possano influenzare negativamente le prestazioni dell'unità.

Scaricare tutta l'acqua dall'impianto idraulico per evitare il congelamento.

Non collocare l'unità vicino a una fonte di calore o a materiali infiammabili, poiché l'unità contiene un gas refrigerante che può provocare un'esplosione se messo a contatto con una fonte di calore o con materiali infiammabili. Non fumare in prossimità dell'unità.

Quando si sostituiscono i componenti elettrici, questi devono essere adatti all'uso previsto e alle specifiche corrette. È necessario seguire sempre le istruzioni di manutenzione e assistenza del produttore. In caso di dubbio, consultare il servizio di assistenza tecnica del produttore.

I seguenti controlli devono essere applicati agli impianti che utilizzano refrigeranti infiammabili:

Le dimensioni della carica sono compatibili con le dimensioni del locale in cui sono installate le parti contenenti il refrigerante;

Le macchine e le uscite di ventilazione funzionano correttamente e non sono ostruite; Se si utilizza un circuito refrigerante indiretto, il circuito secondario deve essere controllato per verificare la presenza di refrigerante; Le marcature sulle apparecchiature devono rimanere visibili e leggibili. Le marcature e i segnali illeggibili devono essere corretti;

I tubi o i componenti del refrigerante sono installati in una posizione tale da non essere esposti a sostanze che potrebbero corrodere i componenti contenenti il refrigerante, a meno che i componenti non siano costruiti con materiali intrinsecamente resistenti alla corrosione o siano adeguatamente protetti contro tale corrosione.

Far controllare regolarmente la pompa di calore da un installatore autorizzato.

Al termine della sua vita utile, questo apparecchio e il gas in esso contenuto devono essere riciclati; rivolgersi al rivenditore.



Guia de instalação e usuário

DC 35 / DC 55 / DC 75 / DC 95 / DC 115



1, avenue de Londres, 13127 Vitrolles, FRANCE

Tel: + 33 4 28 70 69 99

info@warmpac.fr

www.wpool.fr



Sarl com um capital de 62.500 Euros - NIF intracomunitário: FR 08519634851 - SIRET: 519 634 851 00017 - Código APE: 4

Aviso



Antes da instalação, verifique o estado da sua bomba de calor aquando da receção e emita as reservas habituais. Em caso de dúvidas ou problemas, envie uma carta AR ao seu instalador ou contacte o fabricante no prazo de 48 horas. Após este período, nenhuma reclamação poderá ser aceita.

A fim de fornecer aos nossos clientes produtos confiáveis e de qualidade, ele foi fabricado sob rigorosos padrões de fabricação e produção.

Este manual inclui todas as informações necessárias para a instalação, resolução de problemas e manutenção do dispositivo. Consulte este manual antes de fazer manutenção ou operar esta unidade.

A instalação e colocação em funcionamento do seu aparelho devem ser realizadas por pessoal especializado e qualificado em conformidade com as normas de segurança em vigor. Certifique-se de ler este aviso com atenção. Não nos responsabilizamos por quaisquer ferimentos ou danos à máquina resultantes de erros durante a instalação. O não cumprimento destas instruções anulará a garantia.

Utilize apenas peças de reposição originais do fabricante, o não cumprimento desta condição anulará a garantia.



A sua bomba de calor só deve ser utilizada para aquecer uma piscina. A sua utilização está reservada para aquecer e manter a temperatura de uma piscina em condições pré-determinadas por um balanço térmico a realizar com um revendedor antes de escolher a bomba de calor.

Esta bomba de calor cumpre as normas de fabrico e comunicação definidas pela DTP10 da FPP e NFPAC.

AVISO :

Não utilize meios ou processos para acelerar a descongelação ou limpeza da sua bomba de calor. Não perfure, queime ou coloque perto de uma fonte de ignição. O gás refrigerante não deve conter um cheiro forte.

Este dispositivo não deve ser usado por crianças ou pessoas com capacidades físicas ou mentais reduzidas sem supervisão, pois isso pode resultar em ferimentos graves ou morte.

Qualquer intervenção neste dispositivo deve ser realizada por pessoal qualificado, o fabricante e o distribuidor não podem, de forma alguma, ser responsabilizados por danos materiais e/ou corporais causados pelo uso/instalação inadequados.

A instalação deve atender aos padrões elétricos locais e estar devidamente aterrada. O aparelho deve ser desligado antes de qualquer intervenção.

Diretiva 2002/96/EC (WEEE):

O símbolo de um caixote do lixo riscado na parte inferior do aparelho indica que este produto, no final da sua vida útil, deve ser tratado separadamente do lixo doméstico, deve ser levado para um centro de reciclagem de aparelhos elétricos e eletrónicos ou entregue ao revendedor ao comprar um dispositivo equivalente. Directive 2002/95/CE (RoHS) : Ce produit est conforme à la directive 2002/95/CE (RoHS) concernant la limitation de l'utilisation de substances nocives dans les appareils électriques et électroniques.

A instalação de um disjuntor é necessária para evitar o risco de incêndio e choque elétrico. Se a fonte de alimentação estiver danificada, mande-a ser substituída por um profissional para evitar riscos corporais e materiais.



4. Características técnicas

Modelo - Referência		DC35	DC55	DC75	DC95	DC115
Capacidade da piscina	Maxi	35m ³	55m ³	75m ³	95m ³	115m ³
Potência de aquecimento * -	kW	1.4- 6.8	1.3- 7.93	1.75- 10.90	3.21-15.81	3.21- 17.05
Consumo*	kW	0.14- 1.51	0.12- 1.37	0.16- 1.96	0.31- 3.03	0.32- 3.98
COP *		10.0 -45	11.24-5.79	10.88- 5.56	10.3-5.22	10.01-4.82
* Teste realizado a 27°C de temperatura do ar, com a mesma diferença de temperatura e vazão de água obtida a 15°C.						
Corrente nominal	A	1.02-5.18	0.9-6.0	1.2-8.6	1.5-13.3	2.0-17.5
Potência de aquecimento**	kW	1.1- 5.2	0.96 - 6.46	1.52- 8.21	2.3- 12.14	2.07- 15.20
Consumo**	kW	0.21- 1.24	0.19- 1.32	0.25- 1.84	0.37- 2.80	0.38- 3.60
** Teste realizado a 15°C de temperatura do ar, com entrada de água a 26°C e saída de água a 28°C para definir o fluxo de água, capacidade de aquecimento e consumo, de acordo com as normas FPP.						
Capacidade de refrigeração ***	kW	2.2	3.72	4.3	6.2	7.69
Consumo***	kW	1.4	1.45	1.78	3.3	2.66
COP***		1.55	2.57	2.43	1.86	2.89
*** Teste realizado a 35°C de temperatura do ar, com entrada de água a 30°C e saída de água a 29°C.						
Corpo		ASA	ASA	ASA	ASA	ASA
Controlador		Tela de toque digital				
Gás		R32	R32	R32	R32	R32
Permutador		Titânio Retorcido	Titânio Retorcido	Titânio Retorcido	Titânio Retorcido	Titânio Retorcido
Compressor		Rotativa Panasonic	Rotativa Panasonic	Rotativa Panasonic	Rotativa Panasonic	Rotativa Panasonic
Número de fás		1	1	1	1	1
Velocidade de rotação do ventilador (PRM)	T/mn	400-700	400-750	400-800	300-750	400-750
Moda		Calor/Frio/Auto tomático	Calor/Frio/Auto mático	Calor/Frio/Au tomático	Calor/Frio/Auto mático	Calor/Frio/Auto mático
Faixa de operação		-5°C-43°C	-5°C-43°C	-5°C-43°C	-5°C-43°C	-5°C-43°C
Potência acústica a 1m	dB(A)	38-50	41-50	42-51	42-55	45-56
Alimentar		Mono 220-240V/50HZ				

Regulador		Eletrônico	Eletrônico	Eletrônico	Eletrônico	Eletrônico
Fluxo de água	m ³ /H	2.5	2.7	3.5	5.2	5.6
o tamanho da unidade	mm	1000/418/605	1000/418/605	1000/418/605	1046/453/767	1160/490/862
Tamanho da caixa (l/p/h)	mm	1030/435/615	1030/435/615	1030/435/615	1130/480/780	1210/510/880
Peso liquido peso bruto	kg	43/54	47/58	51/62	66/79	74/88
Garantia de todas as peças		3 anos	3 anos	3 anos	3 anos	3 anos

4. Dimensões da bomba de calor

Dimensões : DC 35 – DC 55 – DC 75

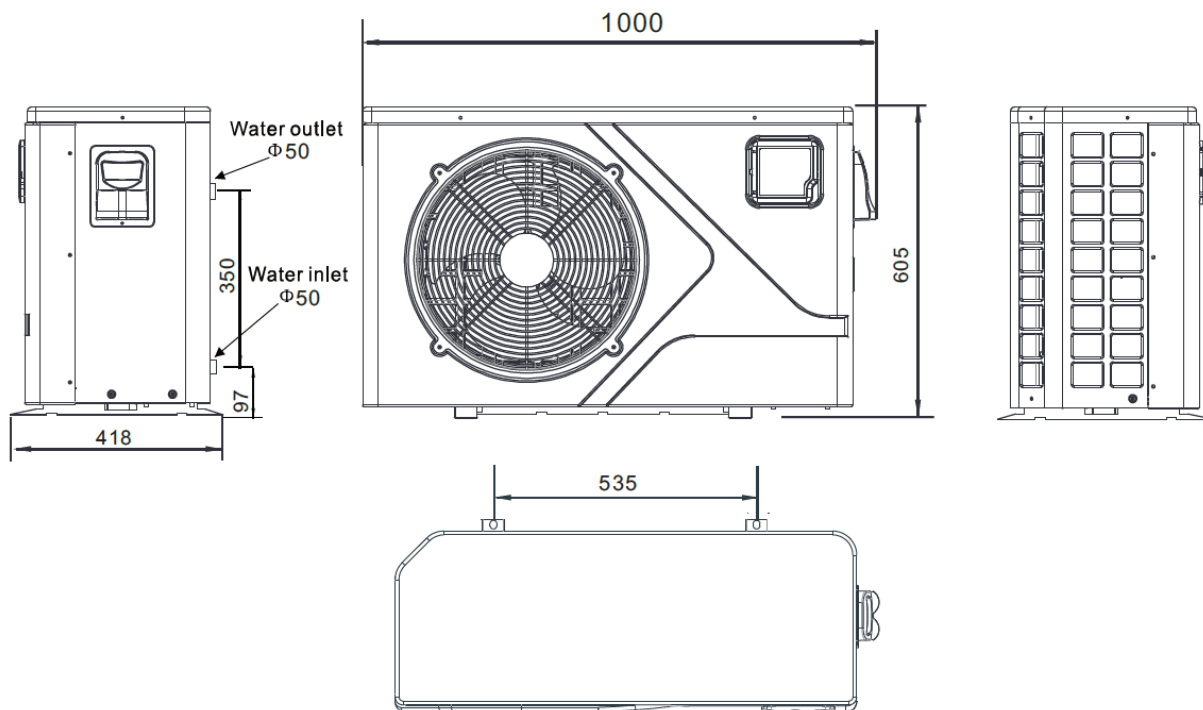

Dimensões: DC 95 :

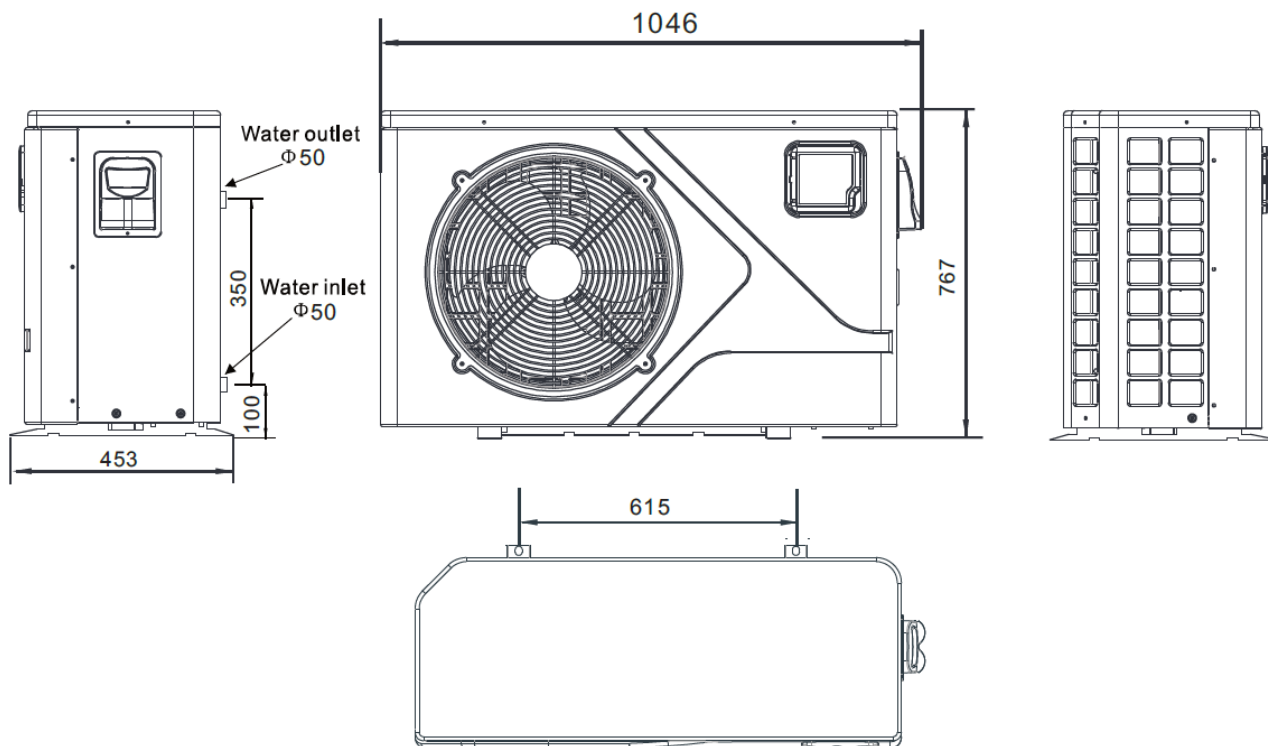

Dimensões: DC 115

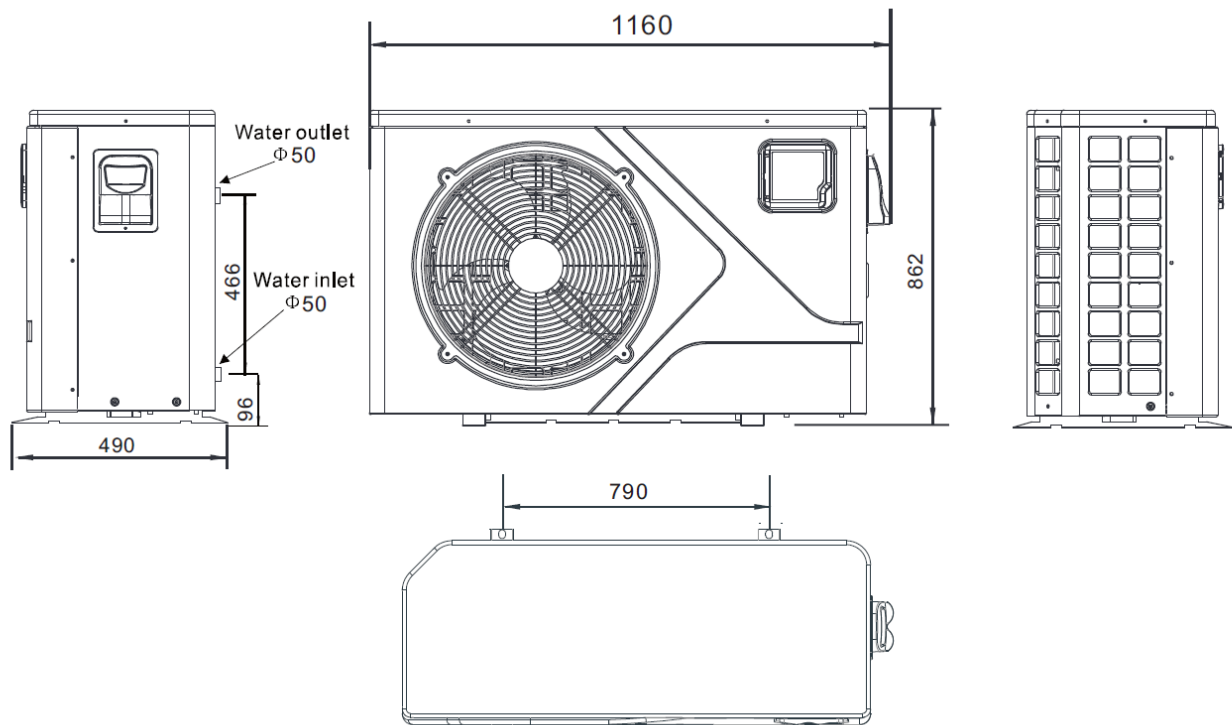

5. Instalação e conexões

Ao usar pela primeira vez, certifique-se de que a piscina esteja cheia de água

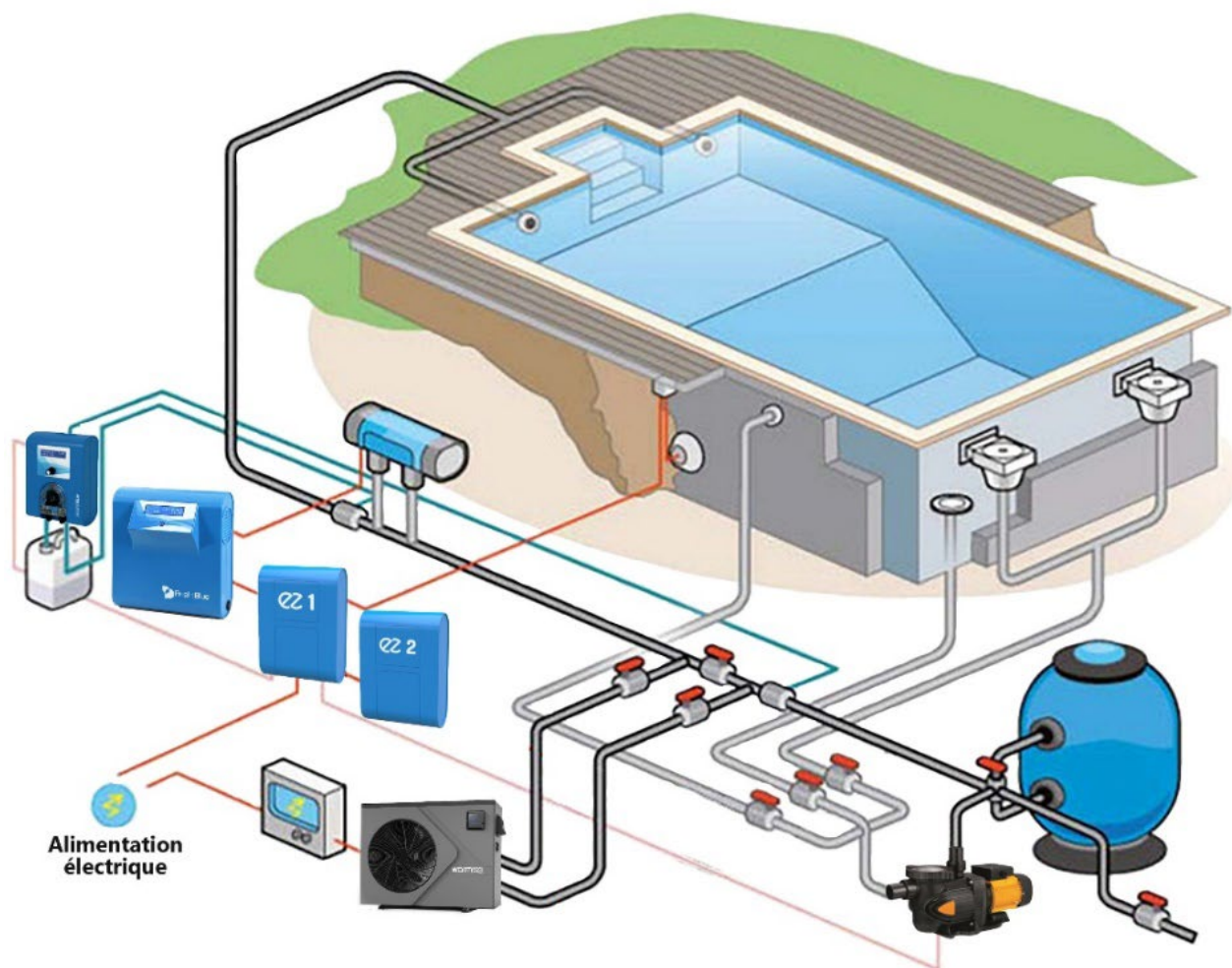

A escolha da sua bomba de calor deve ter sido determinada por um balanço térmico personalizado para ter a certeza de que as suas características vão ao encontro das suas necessidades. A empresa não pode ser responsabilizada em caso de mau desempenho se o seu dimensionamento não for realizado graças a um balanço térmico personalizado e se as condições de uso indicadas durante o balanço térmico não forem respeitadas.

A sua bomba de calor deve ser colocada no exterior e deve respeitar as distâncias mínimas de 3m sem obstáculo à frente do soprador - 50cm da parede para as costas e 15cm acima do solo.

Recomendamos que você use prisioneiros e tenha seus condensados evacuados em um moinho comum (que pode ser coberto com cascalho).

Caso alguma destas recomendações não seja aplicada ou aplicável, pedimos que contacte o fabricante para verificar se a instalação efectuada ou pretendida não afectará o bom funcionamento da sua bomba de calor.

5.1 Conexão hidráulica

O trocador de calor de titânio de fluxo exclusivo da bomba de calor da piscina não requer nenhum arranjo de encanamento especial, exceto o bypass. (Por favor, ajuste o fluxo de acordo com a placa de identificação). A queda de pressão da água é inferior a 10kPa no fluxo máximo. Como não há calor residual ou temperatura da chama, a unidade não requer tubulação de dissipação de calor de cobre. Tubos de PVC podem ser instalados diretamente na unidade.

Localização: Conecte a unidade na linha de descarga (retorno) da bomba da piscina, a jusante de todos os filtros e bombas da piscina e a montante de quaisquer cloradores, ozonizadores ou bombas químicas. O modelo padrão é equipado com conexões de cola deslizante que aceitam tubo de PVC de 32 mm ou 50 mm para conexão com tubulação de filtragem de piscina ou spa.

Considere seriamente a adição de um acoplador rápido à entrada e saída da unidade para facilitar a drenagem da unidade para o inverno e para facilitar o acesso se for necessária manutenção.

Condensação: Como a bomba de calor esfria o ar em aproximadamente 4 a 5 graus, a água pode condensar nas aletas do evaporador. Se a umidade relativa for muito alta, pode ser de vários litros por hora. A água fluirá ao longo das aletas para a bacia de base e drenará o encaixe de drenagem de condensado de plástico farpado na lateral da bacia de base.

Esta conexão foi projetada para aceitar tubos de vinil transparente de 20 mm que podem ser empurrados manualmente e encaminhados para um dreno adequado. É fácil confundir condensação com vazamento de água dentro da unidade.

Observação: Uma maneira rápida de verificar se a água é condensada é desligar a unidade e deixar a bomba da piscina funcionando. Se a água parar de fluir da bacia, é condensação.

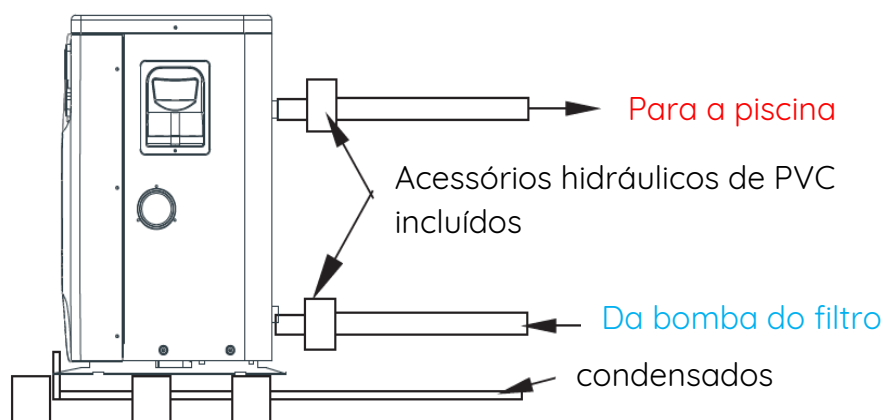

5.2 Conexão elétrica



Importante: A sua bomba de calor deve ser ligada por pessoal autorizado e qualificado. Verifique se o cabo que alimenta a sala técnica tem seção suficiente para suportar o consumo adicional exigido pela máquina.

A bomba de calor deve ser alimentada a partir de um disjuntor de curva D independente que pode estar no quadro elétrico principal equipado com um diferencial ou em um painel independente conectado ao painel principal, que terá um diferencial. Se não for o caso, adicione um diferencial à tabela independente da sua bomba de calor.

Referência	Alimentar	Potência do disjuntor da curva D	Seção do cabo de acordo com a distância do disjuntor - PAC		
			- 10 m	10 -15 m	+ 15 m
DC 35	Monofásico 230V	16 Ampères	3G2.5 mm2	3G2.5 mm2	3G6 mm2
DC 55	Monofásico 230V	16 Ampères	3G2.5 mm2	3G2.5 mm2	3G6 mm2
DC 75	Monofásico 230V	20 Ampères	3G2.5 mm2	3G2.5 mm2	3G6 mm2
DC 95	Monofásico 230V	25 Ampères	3G2.5 mm2	3G2.5 mm2	3G6 mm2
DC 115	Monofásico 230V	25 Ampères	3G2.5 mm2	3G2.5 mm2	3G6 mm2

Conexão elétrica no bloco de terminais da bomba de calor

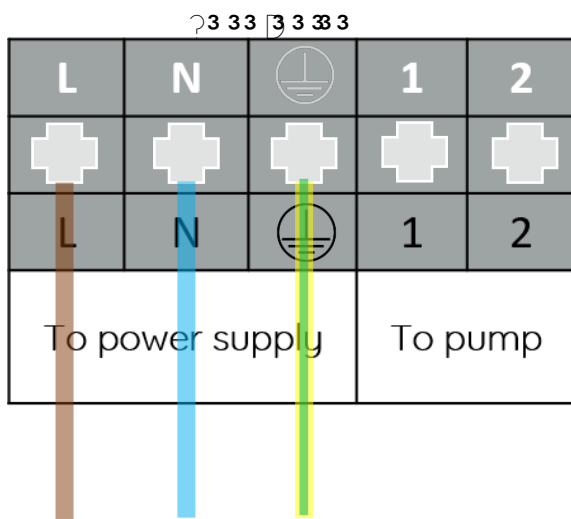

Desparafuse a alça para acessar a conexão elétrica

3 3 3 3 3 3 3

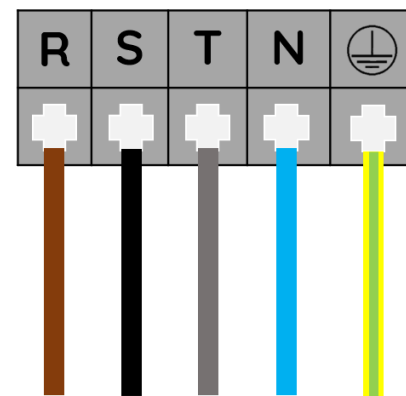

3 3 3 3 3

3 3 3 3 3 3 3

3 3 3 3 3 3 3

4. Comissionamento

Depois de instalar correctamente a sua bomba de calor no circuito hidráulico da sua piscina ou spa, a bomba de filtração da sua piscina deve estar em funcionamento para que a água circule através do permutador de calor da sua bomba de calor.

- 1:** Certifique-se de que as válvulas da sua bomba de calor estão correctamente reguladas: Bypass: aberta a 50%, válvula de entrada: aberta a 100%, válvula de saída: aberta a 70%.
- 2:** Ligue a sua bomba de filtração e verifique se não há fugas no circuito hidráulico e se a água está a circular correctamente através das bocas de descarga da piscina ou spa.
- 3:** Ligar a fonte de alimentação e depois pressionar o botão ON/OFF no comando à distância, se a instalação for feita correctamente, a bomba de calor deve ligar imediatamente.
- 4:** Após alguns minutos, o ar libertado pelo ventilador deve ser significativamente mais fresco do que o ar ambiente.
- 5:** Quando a bomba de calor estiver em funcionamento, desligar a bomba de filtração e a unidade deve parar.
- 6:** Ponha a sua bomba de filtração e bomba de calor a funcionar 24 horas por dia até ser atingida a temperatura desejada. Quando a temperatura desejada for atingida, a unidade abrandará, quando a temperatura for mantida durante 45 minutos e ; a unidade parará e reiniciará automaticamente assim que a temperatura da água for 0,2 °C mais baixa do que a temperatura definida solicitada (Atenção : a sua bomba de filtração deve estar a funcionar para que a bomba de calor funcione).

6. Utilização do controlo remoto

6.1 Apresentação geral

A sua bomba de calor está equipada com um controlo digital de toque que é programado em modo quente por defeito na fábrica.

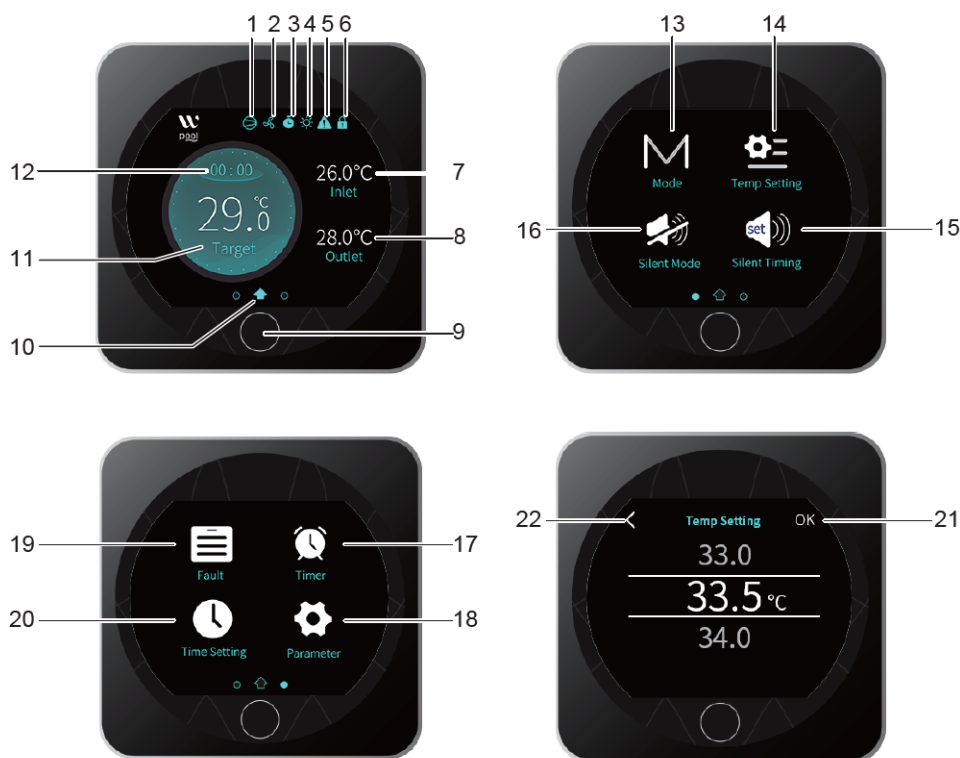

- 1: Indicador de funcionamento do compressor
- 2: Ventilação
- 3: Temporizador
- 4: Modos de regulação de temperatura: quente - frio - automático
- 5: Alarme
- 6: Fechadura de exposição
- 7: Temperatura de entrada de água
- 8: Temperatura de saída de água
- 9 : On/Off/Return
- 10: Ecrã principal
- 11: Temperatura de setpoint
- 12: Tempo do sistema
- 13: Modo de funcionamento
- 14: Mudança de temperatura de setpoint
- 15: Configurações do modo silencioso
- 16: Activar o Modo Silencioso
- 17: Programação do tempo
- 18: Configurações avançadas
- 19: Lista de códigos de erro
- 20: Definição de data e hora

21 : Confirmar

22: Retorno (AVISO: os parâmetros que estão a ser modificados não serão guardados)



OFF :

Quando a bomba de calor está em modo de espera, verá OFF no visor. Após um certo período de tempo, o visor desliga-se e entra em modo de espera.

ON :

Quando a bomba de calor está em funcionamento, o visor fica azul.

Para mudar de um modo para o outro, prima o botão central preto durante 0,5 segundos.

5.2 Definição da data e hora

A data e a hora podem ser definidas como ON ou OFF



Prima uma vez o botão central para voltar ao ecrã principal.

5.3 Definição do programa temporal

Esta função deve ser programada se desejar programar horários de funcionamento da sua bomba de calor (ATENÇÃO: A bomba de filtração da sua piscina deve estar a funcionar para que a sua bomba de calor arranque). Pode programar uma hora de início e uma hora de paragem para a sua bomba de calor.



Blue Tick: Activado

Marca cinzenta: Desligado

Pressionar duas vezes o botão central para voltar ao ecrã principal.



5.4 Ajuste da temperatura do setpoint

A temperatura do setpoint pode ser alterada no modo ON ou OFF com uma precisão de 0,5°C.



Prima uma vez o botão central para voltar ao ecrã principal

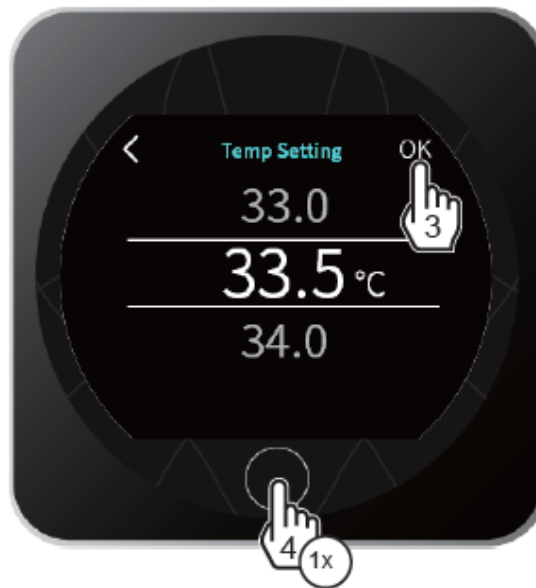

Prima uma vez o botão central para voltar ao ecrã principal

5.5 Selecção do modo de temperatura



Prima uma vez o botão central para voltar ao ecrã principal

5.6 Selecção do modo de temperatura

O ecrã pode ser bloqueado ou desbloqueado no modo ON ou OFF



Prima uma vez o botão central para voltar ao ecrã principal

5.7 Configurar o modo silencioso

O modo Silencioso permite que a bomba de calor funcione de forma muito económica e silenciosa quando a necessidade de aquecimento é baixa (apenas necessitando de manter a temperatura em condições meteorológicas muito favoráveis ou uma necessidade específica de funcionamento ultra silencioso)

Activação / Desactivação



Modo silencioso activado



Modo silencioso desligado



Pressione uma vez para voltar ao ecrã principal



Prima duas vezes o botão central para voltar ao ecrã principal. Uma vez activada, a configuração fica activa 7 dias por semana.

5.8 Códigos de falha / erro

É de notar que algumas operações devem ser realizadas por técnicos autorizados.

Se for detectado um erro pela bomba de calor, aparece um pequeno triângulo na parte superior do ecrã, como se segue:



Quando o problema for resolvido, o erro desaparecerá por si só e o símbolo de erro também desaparecerá.

Para apagar a lista de erros clique no símbolo do caixote do lixo

Pressionar duas vezes o botão do meio para voltar ao ecrã principal

5.9 Lista de parâmetros e códigos de erro

Erro / Mau funcionamento	Code	Motivo	Método de resolução
Sensor de temperatura de entrada de água defeituoso	P01	O sensor está danificado ou em curto-circuito	Verificar ou mudar a sonda
Falha no sensor de temperatura de saída de água	P02	Sonda está danificada ou em curto-circuito	Verificar ou mudar a sonda
Falha no sensor de temperatura do ar ambiente	P04	A sonda está danificada ou em curto-circuito	Verificar ou mudar a sonda
Falha da sonda de temperatura Exchanger 1	P05	Sonda está danificada ou em curto-circuito	Verificar ou mudar a sonda
Falha da sonda de temperatura Exchanger 2	P15	Sonda está danificada ou em curto-circuito	Verificar ou mudar a sonda
Falha na sonda de temperatura SUT	P07	Sonda está danificada ou em curto-circuito	Verificar ou mudar a sonda
Falha na sonda de temperatura ET	P081	Sonda está danificada ou em curto-circuito	Verificar ou mudar a sonda
Falha da sonda ET (protecção)	P 082	Sobrecarga de compressores	Verificar se o sistema e o compressor estão a funcionar correctamente
Falha na sonda de temperatura anticongelante	P 09	Sonda está danificada ou em curto-circuito	Verificar ou mudar a sonda
Falha na sonda de pressão	PP	Sonda está danificada ou em curto-circuito	Verificar ou mudar a sonda
Compressor de alta pressão	E 01	Detectado problema de pressão dos compressores	Verificar as definições da válvula (By Pass aberto 70% - Válvula de entrada de água aberta 100% e válvula de saída de água aberta 70%). Verificar o sensor de pressão e o sensor de fluxo.
Compressor de baixa pressão	E 02	Detectado problema de pressão dos compressores	Verifique e/ou substitua o sensor de pressão e contacte o seu instalador para verificar o circuito do refrigerante.
Sensor de fluxo	E 03	Erro detectado no sensor de fluxo	Verifique a circulação da água no seu circuito hidráulico se a bomba de filtração não estiver ligada, a sua bomba de calor não funcionará. Verificar as definições da válvula (By Pass aberto 70% - Válvula de entrada de água aberta 100% e válvula de saída de água aberta 70%). Verificar e/ou substituir o sensor de fluxo
Protecção da temperatura demasiado baixa	E 05	A temperatura ambiente ou da água é demasiado baixa	Verificar a temperatura da água e ambiente

Abertura de entrada/saída de água	E 06	O fluxo de água não é suficiente	Verificar a circulação da água e a configuração das válvulas (By Pass aberto 70% - Válvula de entrada de água aberta 100% e válvula de saída de água aberta 70%)
Protecção contra congelação	E 07	O caudal de água não é suficiente	Verificar a circulação da água e a configuração das válvulas (By Pass aberto 70% - Válvula de entrada de água aberta 100% e válvula de saída de água aberta 70%)
Protecção contra geada principal	E 19	A temperatura ambiente é demasiado baixa	Verificar o sensor de temperatura ambiente
Protecção secundária anti-congelamento	E 29	A temperatura ambiente é demasiado baixa	Verificar o sensor de temperatura ambiente
Protecção contra sobrecarga de compressores	E 051	Compressor está sobrecarregado	Verificar se o sistema e o compressor estão a funcionar normalmente
Falha de comunicação	E 08	Falha de comunicação entre o controlo e a placa mãe	Verificar a ligação entre o controlo e a placa mãe
Falha de comunicação (módulo de controlo de velocidade)	E 081	Módulo de controlo de velocidade e unidade de controlo que não comunica	Verificar a ligação
Temperatura ambiente demasiado baixa	TP	Temperatura ambiente demasiado baixa	Verificar o sensor de temperatura ambiente
Avaria detectada no ventilador	F 051	Foi detectado um problema no motor do ventilador	Verificar se o motor do ventilador está partido ou bloqueado.
Avaria no motor do ventilador	F 031 F 032	O motor do ventilador está bloqueado, a ligação não parece funcionar normalmente	Substituir o motor do ventilador

É de notar que algumas operações devem ser realizadas por técnicos autorizados.

Se for detectado um erro não listado aqui, por favor contacte o seu revendedor.

6 Diagrama de interface

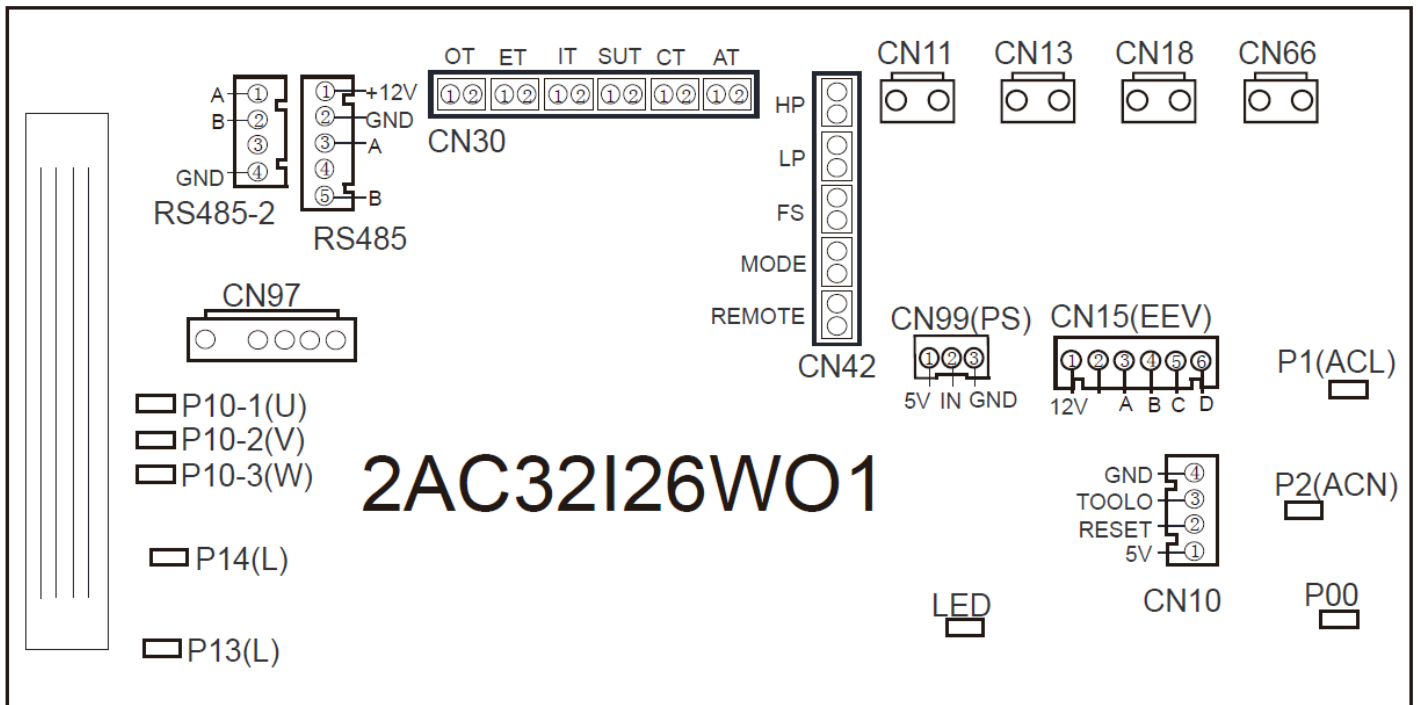
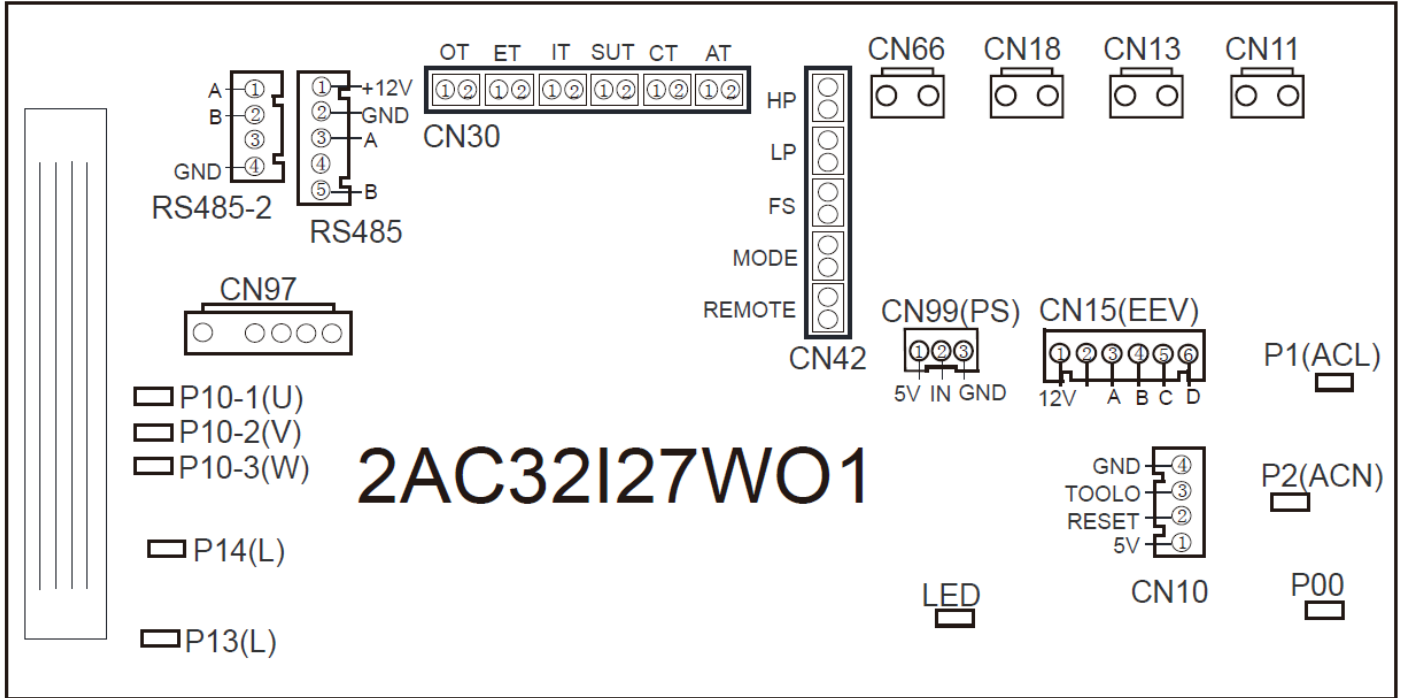

7 Diagrama da placa mãe

Number	Sign	Meaning
01	P10-1/2/3(U/V/W)	Compressor
02	P13(L)	Resistance
03	P14(L)	Resistance
04	CN97	DC motor
05	RS485-2	The port for centralized control
06	RS485	Color line controller communication/WIFI
07	OT	Water output temperature
08	ET	System exhaust temperature
09	IT	Water input temperature
10	SUT	System suction temperature
11	CT	System fan coil temperature
12	AT	Ambient temperature
13	HP	System high pressure
14	LP	System low pressure
15	FS	Water flow switch
16	MODE	Mode switch
17	REMOTE	Emergency switch
18	CN66	Compressor signal
19	CN18	Water pump
20	CN13	Reserved
21	CN11	4-way value
22	CN99	Low pressure sensor
23	CN15	Electronic expansion valve
24	P1	Live wire
25	P2	Neutral wire
26	CN10	Program port

8 Diagrama da placa mãe



Descarregar a aplicação Aquatemp



Parâmetros técnicos

VOLTAGEM OPERACIONAL: CD8V-12V (valor recomendado 12V) consumo máximo 1 A, corrente de espera média 50mA

RAMANHA TEMPERATURA: Temperatura de funcionamento: -30 ~ +70; Temperatura de armazenamento: -40 ~+85

LED INDICADOR: 4 luzes, Indicador de configuração de rede, Indicador de ligação de router, Indicador de ligação de servidor de nuvem, Indicador de comunicação 485;

DIMENSÃO(L×w×H) 78mm×63mm×24mm

Na parte de trás do módulo WFI, existe um íman, que pode ser instalado dentro ou fora de casa, protegido da luz solar directa;

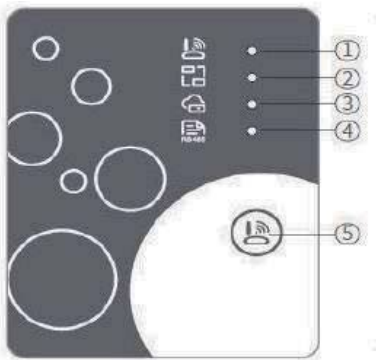

Luz indicadora	Significado	Luz longa	Luz intermitente	Desactivação
1	Indicador de configuração de rede	Configuração de rede	Configuração do Smart Link	Concluído
2	Indicador de ligação do router	Normal	Anormal	Desligado / Em comunicação
3	Indicador de ligação ao servidor de nuvens	Normal	Anormal	Desligado / Em comunicação
4	485 indicador de comunicação	Normal	Anormal	Desligado / De prevenção
5	Botão de configuração, ligar	----	----	Imprensa brevemente

Login: Utilize o endereço de correio electrónico e a palavra-passe para se registar, iniciar sessão ou redefinir a palavra-passe.

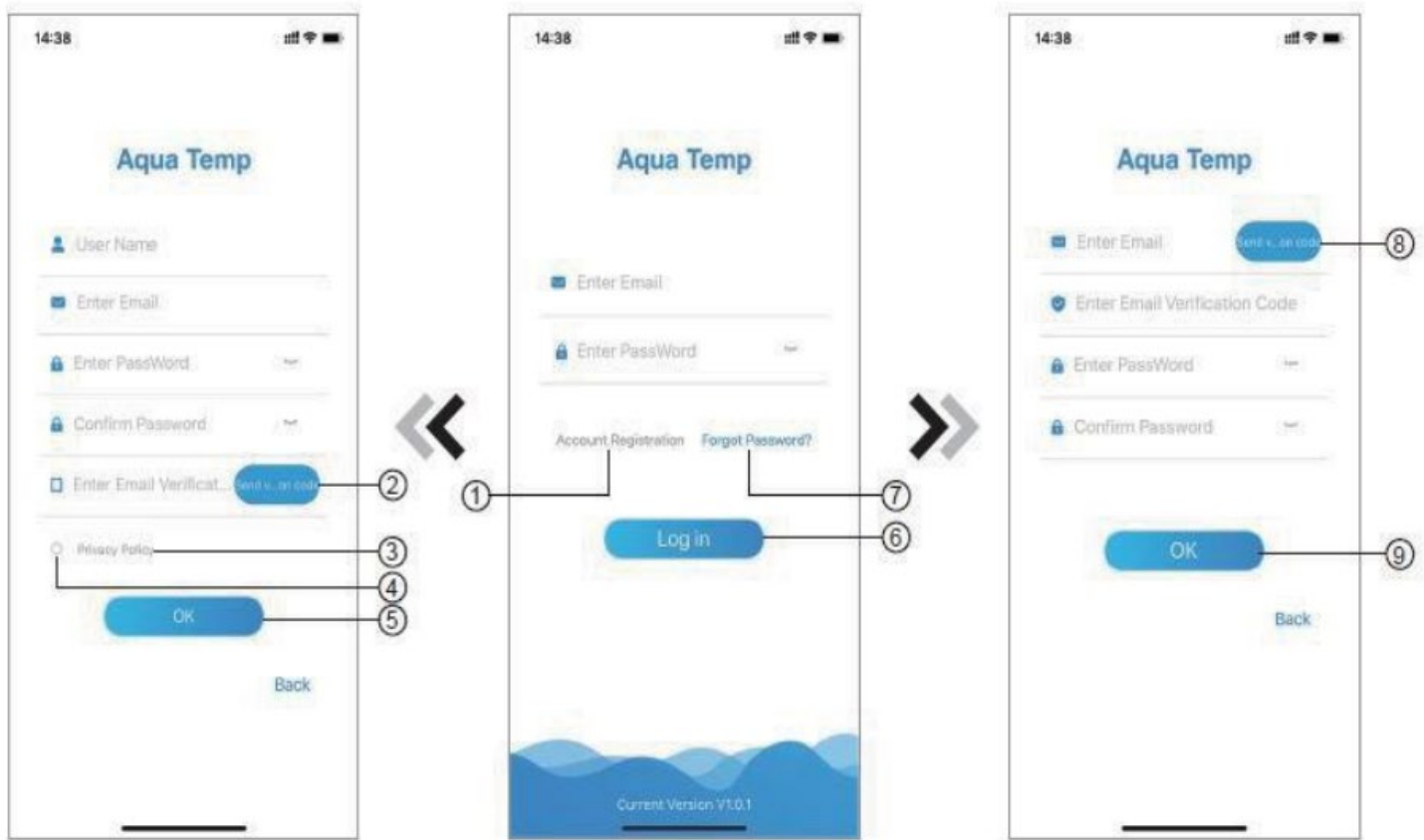

Registo da conta: Para registar uma conta, clique em 1 (Fig.1) para entrar na interface de registo da conta, preencha as informações e clique em 2 para receber o código de verificação, enquanto preenche as informações solicitadas, clique em 3 para ler os detalhes da política de privacidade, clique em 4 para aceitar, e clique em 5, o registo está completo. Note que a validade de um código de verificação é de 15min, por favor preencha o código de verificação dentro de 15min, caso contrário terá de solicitar um novo.

Login: Siga as instruções na página (Fig.1), introduza o endereço de correio electrónico registado e a palavra-passe, clique e vá para a lista de dispositivos. Quando tiver esquecido a sua palavra-passe, clique na palavra-passe esquecida e siga as instruções.

Adicionar um dispositivo: Clique em adicionar um novo dispositivo e siga as instruções para adicionar o WIFI ou DTU.

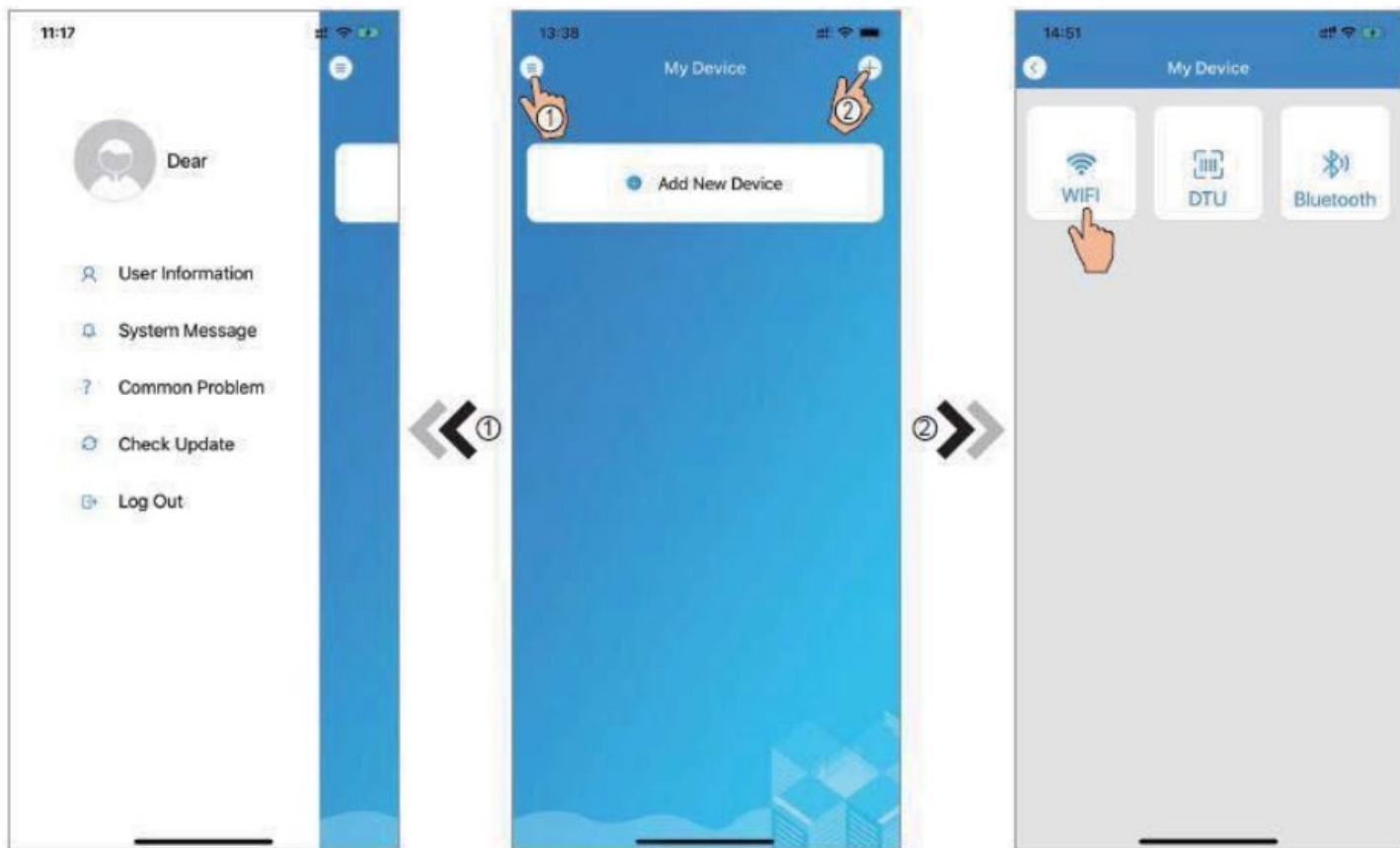

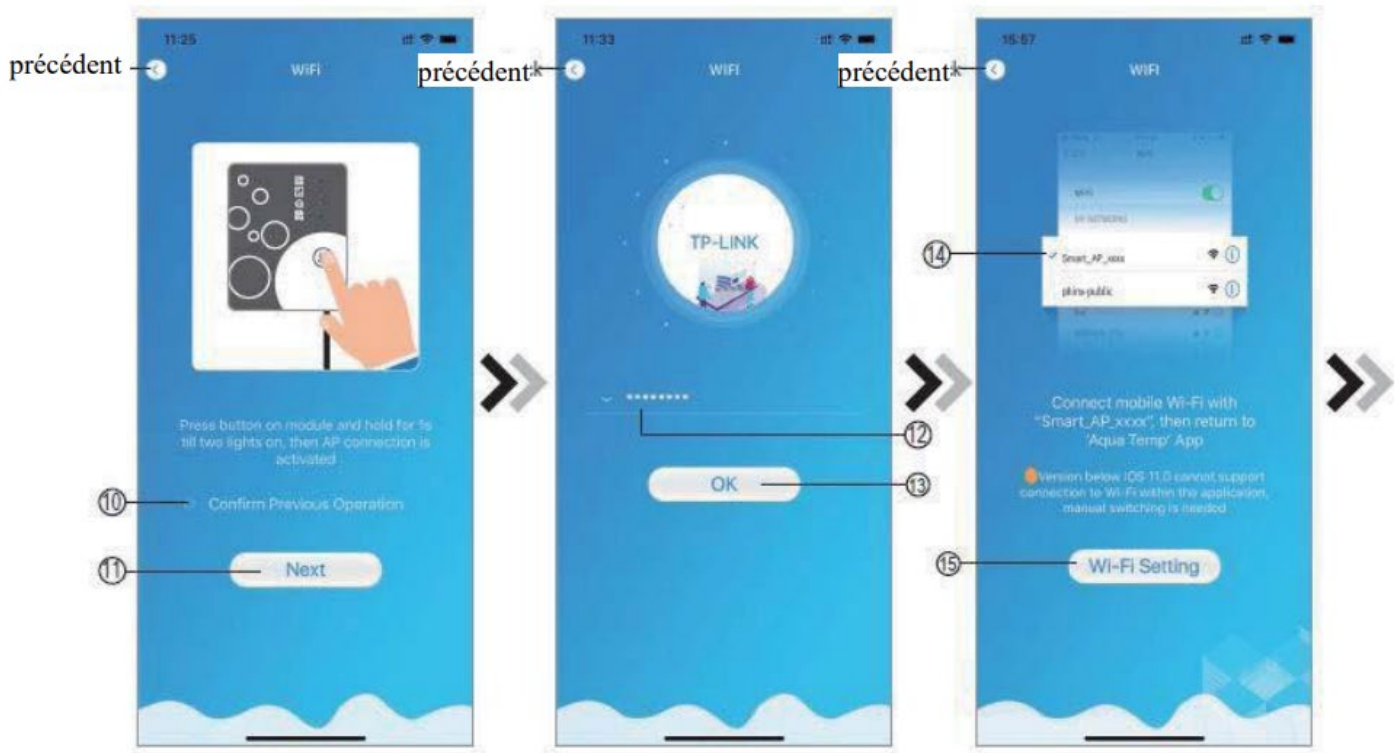

Configuração WiFi :

Siga as instruções na página. Manter premido o botão no módulo durante 1 segundo até que se acendam duas luzes. Clique 11 para confirmar, introduza a palavra-passe WiFi para estabelecer a ligação e clique em confirmar. Ir às definições do sistema e ligar o WiFi especificado, seleccionar "Smart_ AP_ xxx", clicar em ok e seguir as instruções para ir à interface de configuração WiFi.

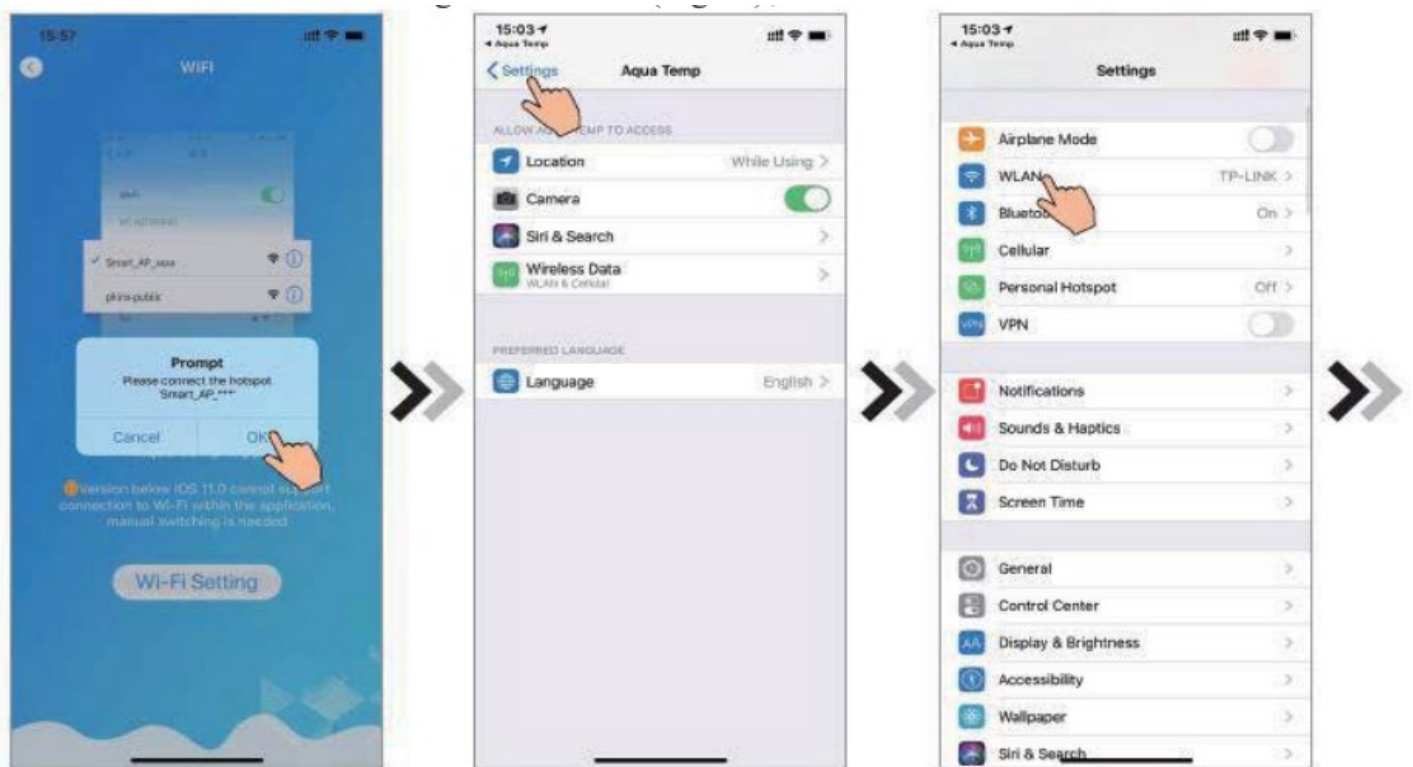

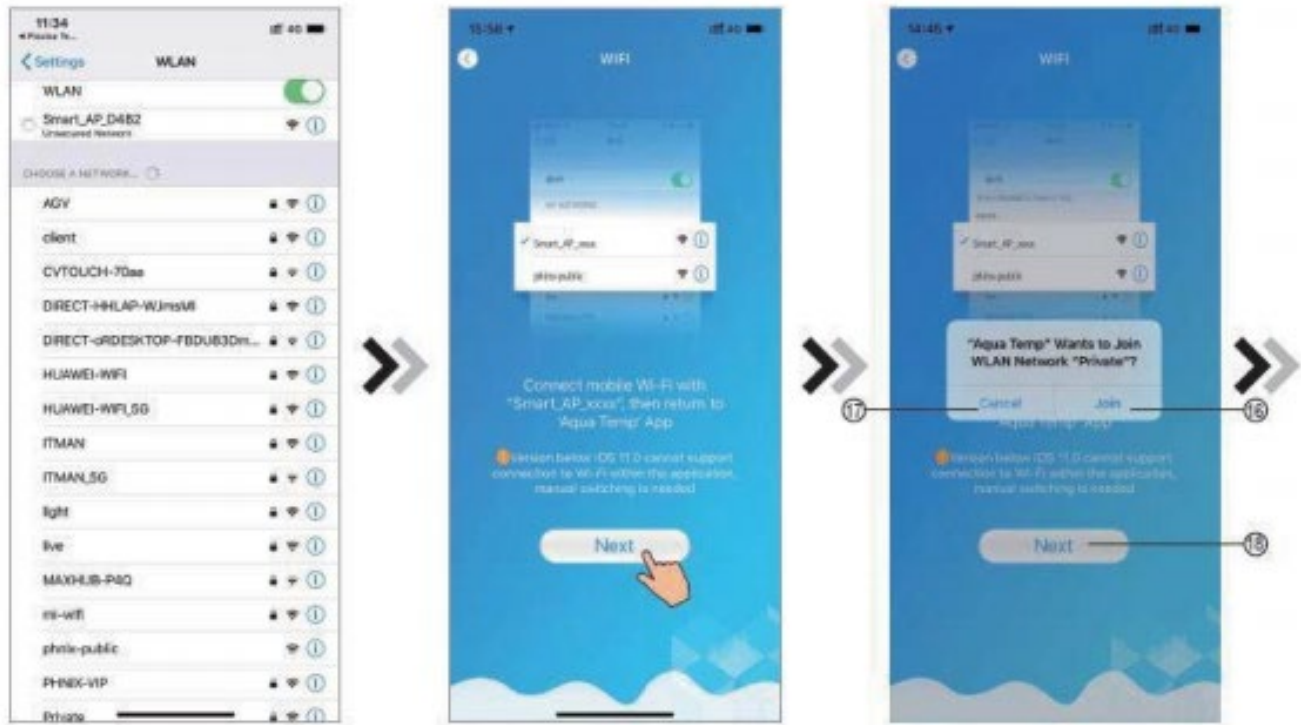







Gestão de Dispositivos :

Uma vez concluída a ligação WiFi e DTU, regressar ao Meu Dispositivo.

As operações de gestão do dispositivo são as seguintes:





	Nome	Funções
	Activar/Desactivar	Clique para activar/desactivar o dispositivo
	Modo Silencioso	Clique para activar o modo silencioso
	Modo Offset	Modo de mudança: Calor, Arrefecimento ou Automático
	Parâmetros do cronómetro	Clique para activar/desactivar e silenciar o temporizador
	Resolução de problemas	Clique para aceder à interface de resolução de problemas
	Menu	Clicar para expandir ou fazer cair o menu

9 Garantia do fabricante

A garantia do fabricante é de 3 anos. Para além desta garantia de peças, fornecemos também uma garantia laboral, que só está incluída no caso de devoluções às nossas oficinas. Se o fabricante solicitar a devolução da bomba de calor, os custos de transporte para a devolução à oficina devem ser pagos pelo cliente e os custos de devolução da bomba de calor ao cliente devem ser pagos pelo fabricante.

Esta garantia é exclusiva e substitui todas as outras garantias implícitas de comerciabilidade ou adequação a um determinado fim e todas as outras garantias expressas ou implícitas. Os recursos previstos nesta garantia são exclusivos e constituem a única obrigação da Warmpac e qualquer outra representação feita por qualquer pessoa não terá qualquer consequência.

10 Conselhos de segurança



Não tocar no ventilador enquanto este estiver a funcionar, pois isto poderia causar lesões,

Verifique regularmente a alimentação eléctrica e os cabos de ligação da sua bomba de calor. Se tiver alguma dúvida, contacte o seu instalador,

No caso de uma chamada de serviço, deverá utilizar as peças originais do fabricante.

O ambiente em redor da bomba de calor deve estar sempre limpo, devidamente ventilado e livre de quaisquer elementos que possam influenciar negativamente o desempenho da unidade.

Drenar toda a água do sistema hidráulico para limitar o congelamento.

Não colocar a unidade perto de uma fonte de calor e/ou materiais inflamáveis, pois a unidade contém um gás refrigerante que pode resultar numa explosão se posta em contacto com uma fonte de calor e/ou materiais inflamáveis. Não fumar perto da unidade.

Quando os componentes eléctricos são substituídos, devem ser adequados para o uso pretendido e à especificação correcta. As directrizes de manutenção e serviço do fabricante devem ser seguidas a todo o momento. Em caso de dúvida, consultar o departamento técnico do fabricante para obter assistência.

Os seguintes controlos devem ser aplicados a instalações que utilizem fluidos refrigerantes inflamáveis:

O tamanho da carga é consistente com o tamanho da sala em que as peças que contêm o refrigerante são instaladas;

Se for utilizado um circuito de refrigerante indirecto, o circuito secundário deve ser verificado quanto à presença de refrigerante; a marcação no equipamento deve permanecer visível e legível. As marcações e sinais ilegíveis devem ser corrigidos;

Os tubos ou componentes de refrigerante são instalados numa posição em que não é provável que sejam expostos a qualquer substância que possa corroer os componentes que contêm o refrigerante, a menos que os componentes sejam feitos de materiais inerentemente resistentes à corrosão ou estejam adequadamente protegidos contra tal corrosão.

Mande verificar regularmente a sua bomba de calor por um instalador autorizado.

No final da sua vida útil, este aparelho e o gás que contém devem ser reciclados, por favor contacte o seu revendedor.