

WARM POOL

Designed by
warmPAC

Installation & Operation Manual EZ35 - EZ55 - EZ75



3 ANS toutes pièces



www.warmpool.fr

1. Warning

First and foremost, check the condition of your heat pump as soon as you receive it, write any reservations you have about its state on the delivery note if you have any doubts or a problem and send a registered letter to your installer or directly to the manufacturer within 48 hours. After this period, no claim will be accepted.

1.1 Important information

To properly install your heat pump, read this manual carefully. We will not be liable for any injury to persons or damage to the machine due to any errors that might occur during installation.

- The installation of this heat pump must be carried out by qualified personnel,
- This heat pump meets the manufacturing and communication standards defined by FPP's DTP10 and NFPAC,
- The maintenance of this heat pump must be carried out as set out in this manual,
- Only use original spare parts supplied by the manufacturer,
- Failure to follow these instructions or the information in this manual will void the heat pump's guarantee.

2. Your heat pump

2.1 Main features

Your heat pump must not be used for any purpose other than to HEAT your pool. Its choice was determined following a personalized heat budget and it cannot be used for other pools until a new heat budget has been carried out.

Your heat pump is one of the most efficient and environmentally friendly heaters, using R32 gas.

2.2 Caractéristiques techniques				
MODELE		EZ35	EZ55	EZ75
Pool size	Maxi	35m ³	55m ³	75m ³
Heating capacity *	kW	5.4	8.7	15.01
Power consumption *	kW	0.98	1.6	2.55
COP *		5.51	5.44	5.89
Rated current	A	4.35	6.66	10.62
Heating capacity **	kW	4.05	6.7	8.9
Power consumption **	kW	0.93	1.46	2.2
Cooling capacity ***	kW	3.1	4.82	5.9
Cooling power consumption ***	kW	1	1.95	2.28
EER ***		3.1	2.48	2.58
Casing material		ASA	ASA	ASA
Controller		Touch screen LCD display		
Gas		R32	R32	R32
Heat exchanger		Titanium twist		
Compressor		Rotary GMCC	Rotary GMCC	Rotary GMCC
Number of fans		1	1	1
Fan rotation speed (PRM)	T/mn	870	840	840
Mode		Cooling / Heating / Auto	Cooling / Heating / Auto	Cooling / Heating / Auto
Operating range		-5°C ~ 43°C	-5°C ~ 43°C	-5°C ~ 43°C
Noise level at 1 m	dB(A)	49	52	52
Power supply		Mono 220-240V/50HZ	Mono 220-240V/50HZ	Mono 220-240V/50HZ
Throttling		Capillaire		
Water volume	m ³ /H	2.2	3.0	4.5
Unit dimension	mm	790×341×575	1000×418×605	1000×418×605
Carton dimension (l/L/h)	mm	846×360×590	1070×450×630	1070×450×630
Net weight / Gross weight	kg	37/45	53/68	56/68
All parts guarantee		3 ans	3 ans	3 ans

* Test carried out at an air temperature of 27°C, with the same temperature difference and water as at 15°C.

** Test carried out at an air temperature of 15°C, with an inlet water temperature of 26°C and an outlet water temperature of 28°C to define the water flow, heating capacity and power consumption, according to FPP standards.

*** Test carried out at an air temperature of 35°C, with an inlet water temperature of 30°C and an outlet water temperature of 29°C.

2.3 EASYPAC 35 dimensions (en mm)

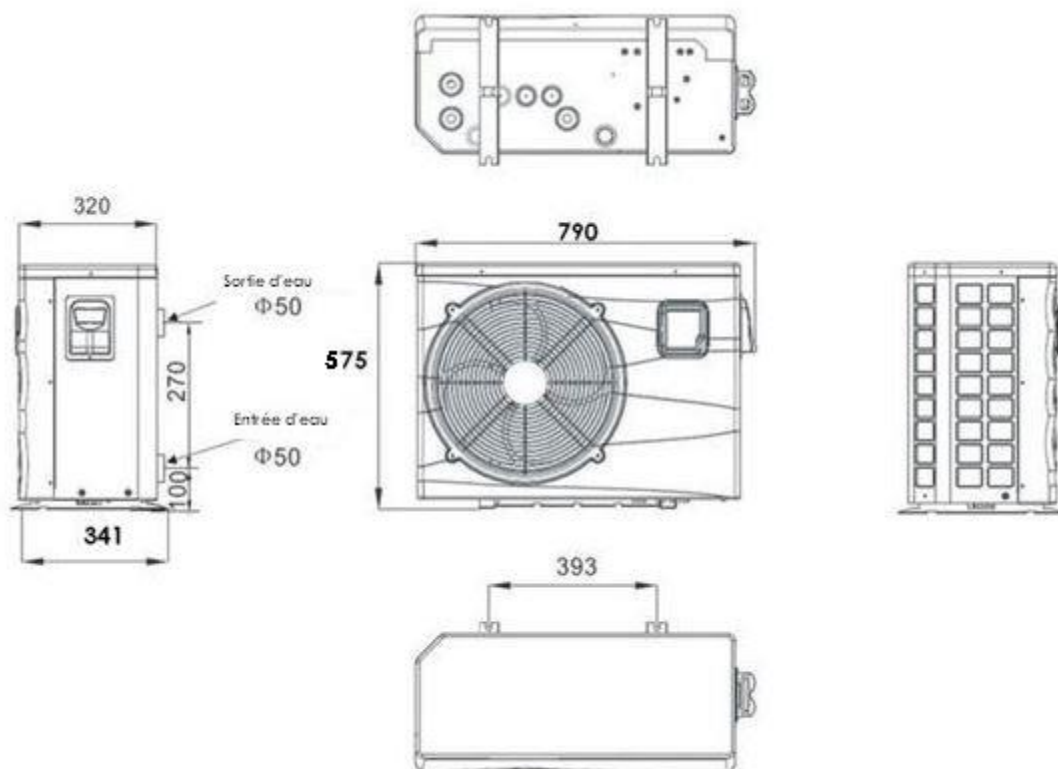

2.4 EASYPAC 55 / 75 dimensions (en mm)

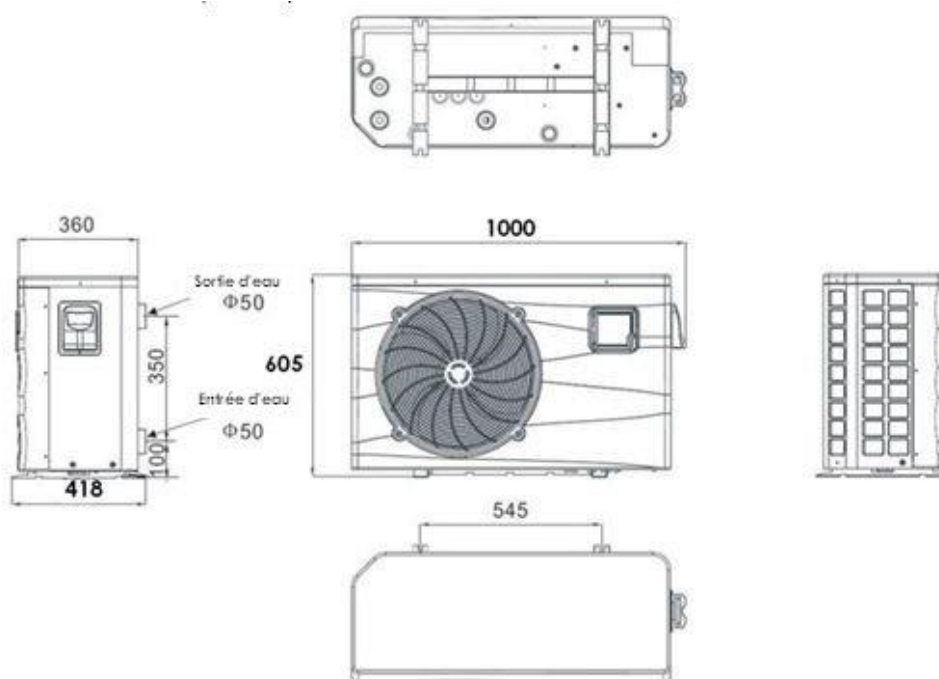

3. Installation and connections

3.1 Installation

Your heat pump and your pool pump must be installed close to each other.

Your heat pump must be placed outdoors and must follow the minimum spacings shown on the connection diagram.

Your heat pump should be level and at least 15 cm above the ground. We recommend you use blocks and drain the condensation into a sump (which can be covered with gravel).

If any of these recommendations are not followed or are not applicable, please contact the manufacturer to make sure that the installation performed or to be performed will not affect the proper functioning of your heat pump.

Using your heat pump will necessarily create condensation (up to several litres of water per hour). This is not a leak.

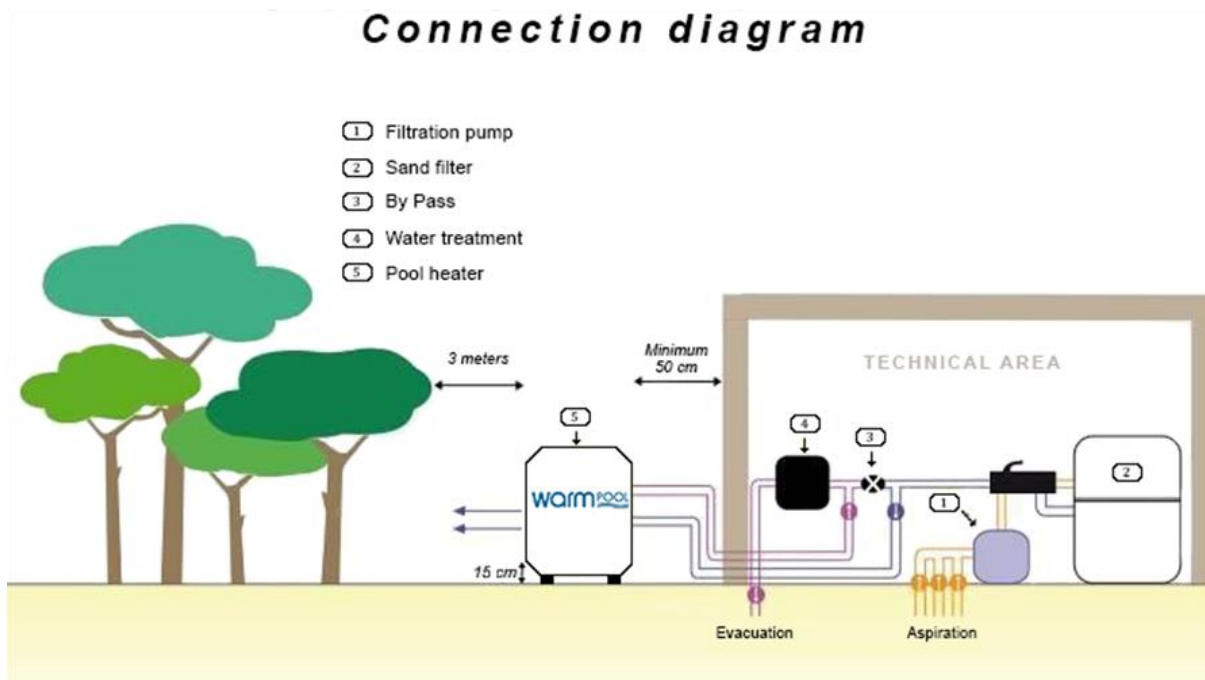

3.2 Hydraulic connection

Before carrying out any work, remember it is vital that all the valves are closed.

As you can see from the connection diagram, you need to install a BYPASS valve (if you do not already have one) between the filtration system and the water treatment system (or discharge).

Upstream of this BYPASS, an OUT pipe with a shut-off valve will be connected to the water inlet of the heat pump and a RETURN pipe with a shut-off valve will be connected to the water outlet of the heat pump.

Use the PVC connectors provided in the accessory kit to connect the hoses to the heat pump. On the pump side, fasten the supplied fittings using Teflon tape to ensure a good seal.

Important: Before filling the pump with water, we recommend washing/rinsing the filter.

3.3 Electrical connection

Important: The electrical connection of your heat pump must be carried out by someone qualified to do it. Check that the cable supplying the machine room is rated for the additional current required by the pump.

The heat pump must be powered from a separate D-curve circuit breaker which may be either on the main electrical panel fitted with a differential circuit breaker or on an independent panel connected to the main switchboard, with a differential circuit breaker. If this is not the case add a differential circuit breaker to the heat pump's independent panel.

Model	Supply	Circuit breaker rating D-curve	Cable cross-section as a function of the distance between the circuit-breaker and the heat pump		
			< 10m	10 to 15m	> 15m
Easypac 35	Single phase 230V	10 Amps	3G1.5 mm ²	3G1.5 mm ²	3G2.5 mm ²
Easypac 55	Single phase 230V	16 Amps	3G2.5 mm ²	3G2.5 mm ²	3G6 mm ²
Easypac 75	Single phase 230V	16 Amps	3G2.5 mm ²	3G2.5 mm ²	3G6 mm ²

Unscrew the knob to access the electrical connection.



L : Phase (fil marron)
N : Neutre (fil bleu)
⊕ : vert et jaune (terre)
1 & 2 : Contact asservissement PAC

4. Start-up

a) Checking the valves

The BYPASS valve must be fully open.

The inlet and outlet water valves must be closed.

b) Clean the filter

c) Valve settings

Open your valves following the order and setting recommended below, and check for water leaks.

- Set the BYPASS valve to half open,
- Fully open the water inlet valve of the heat pump,
- Set the water outlet valve of the heat pump to 1/3.

At the end of these adjustments, check your sand filter pressure gauge, the pressure should not increase beyond 0.2 bar (the pressure should stay in the green zone).

Press the ON/OFF button  to start the heat pump.

~ 7 ~

Important: Leave the machine running for at least 10 minutes before changing the initial valve settings to get a difference between the inlet and outlet water temperatures of between 1°C and 3°C

Remember to clean your filter every week to ensure the proper operation of not only the filter but also the heat pump.







5. Using the heat pump

















Wireless remote-control operation and use instructions

5.1 Interface screen



5.2 Instructions and functions of the icon keys

Main symbols	Name	Function
	Silent mode	Silent mode available only on our Inverter models.
	Mode switch	Changes the operating mode and the access to parameter settings.
	On-Off switch	Start and stop button, cancels an operation in progress and returns to the previous operating level.
	Up switch	Used to scroll through the parameters and operating and temperature values.
	Down switch	Used to scroll through the parameters and operating and temperature values.
	Clock switch	The clock allows the user to set the time. It is important to set the time so that the operating programs saved in synchronisation remain active.

Main symbols	Name	Function
	Cooling symbol	Displayed when cooling the water.
	Heating symbol	Displayed when heating the water.
	Automatic symbol	Displayed in automatic mode.
	Defrost symbol	Displayed when the unit is in the defrosting process.
	Compressor symbol	Displayed when the compressor is running.
	Water pump symbol	Displayed when the heat pump detects water flowing through the heat pump and that the water circulation pump is operating correctly.
	Fan symbol	Displayed when the fan is running.
	Silent mode	Displayed only when this mode is active or programming is active. Available only in our Inverter ranges.
	Schedule Programming	Displayed when a time schedule is being recorded.
	Water outlet symbol	Displays the water outlet temperature.
	Water inlet symbol	Displays the water inlet temperature.
	Lock symbol	Displayed when the keypad is locked.
	Error symbol	In the event of a failure of the unit, an error code will be displayed on the screen.
	Wireless signal symbol	When the device is connected to the WIFI module, this icon appears on the display and the number of bars depends on the WIFI signal strength.
	Degrees Celsius Symbol	Displays temperatures in degrees Celsius.
	Degrees Fahrenheit Symbol	Displays temperatures in degrees Fahrenheit. To change the temperature display, go to the operating parameters

Main symbols	Name	Function
SET	Setting symbol	Used to set a parameter.

5.3 Starting up your heat pump

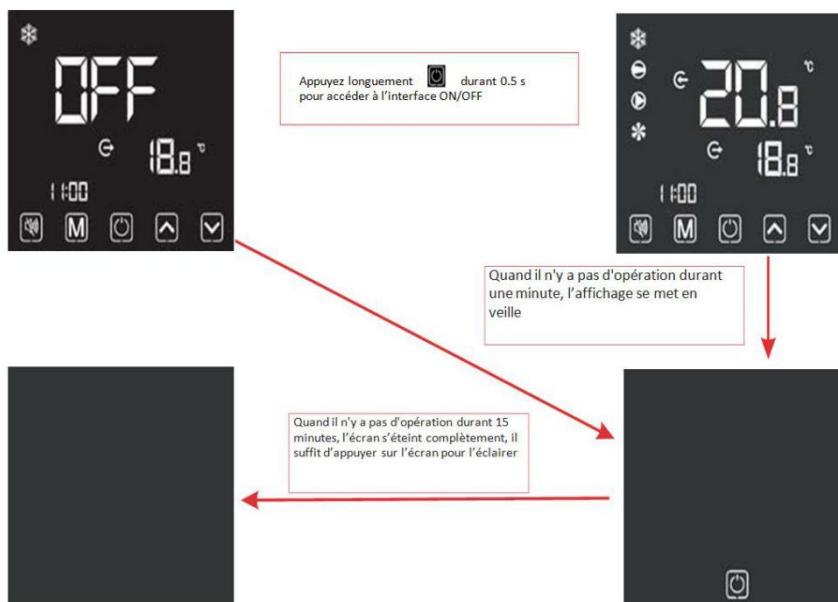

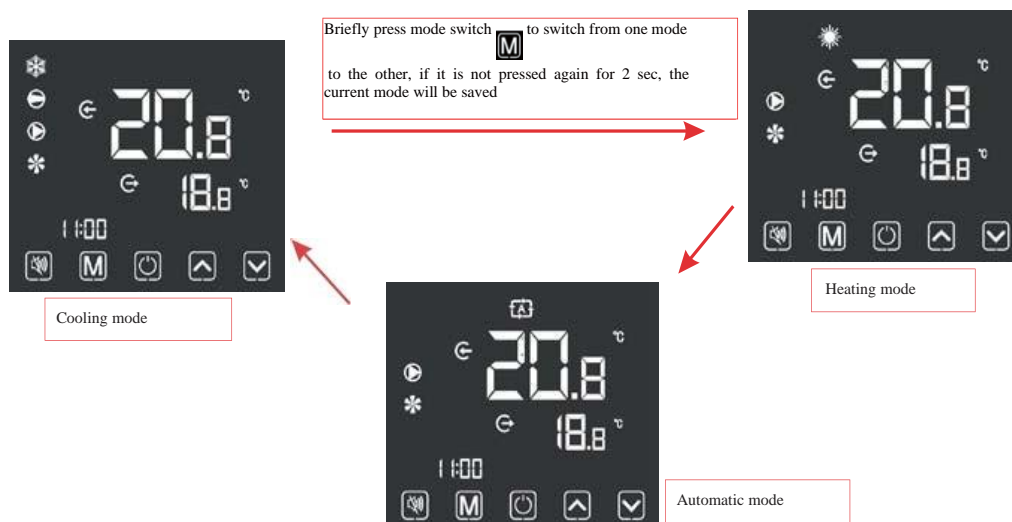

❖ Change of mode

In the main interface, briefly press "M" to toggle the unit between heating, cooling and automatic modes.

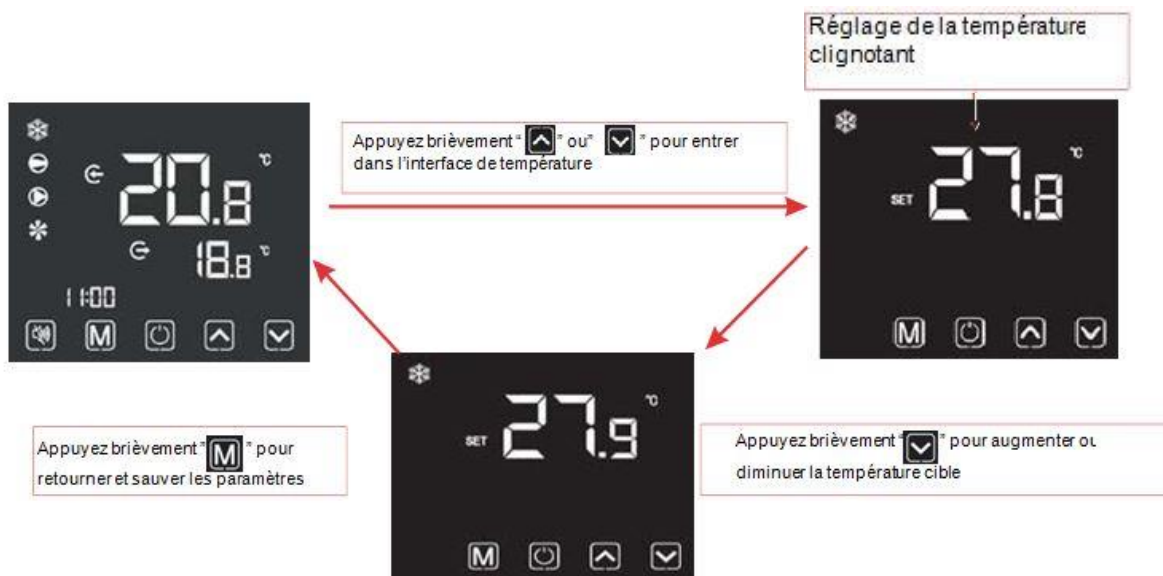

❖ Temperature settings



Comments: In the temperature setting interface, if you briefly press , the system will return to the main display and no changes will be saved. When the temperature appears on the display after you set the value you want, wait 5 seconds and the temperature displayed will be saved as the set temperature. The system will automatically store the user setting and return to the main interface.



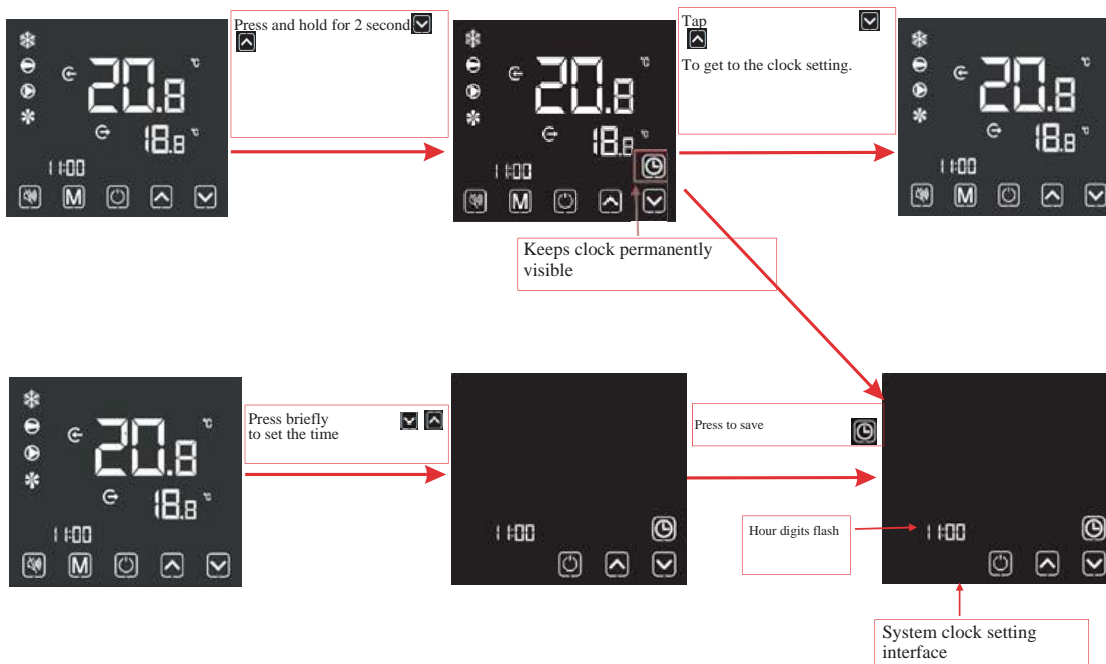

❖ Setting the clock



Locking the controller

To lock or unlock the wireless controller press the  symbol for 5 seconds.

Schedule programming

To get to this function press the up and down arrows for 2 seconds at the same time, the  symbol will be displayed. Press the  symbol for 3 seconds to display the  symbol. To set your schedule, use the up and down arrows. To check your programme and exit press .

Silence mode

When silent mode is active, it appears on the screen with this symbol .

To program an operating schedule, press and hold 2 sec .

Then press the up and down arrows to set a PAC start time on "ON" and off on "OFF".

To stop the silence option, go to the "OFF" time setting using the UP and DOWN keys, then press . This icon will disappear.

5.4 Error code

When the unit detects a failure, an error code is shown on the controller. The following table gives the description of the error and the action to take.

ERROR CODE	DESCRIPTION
E01	The HP pressure switch has detected an abnormality in the refrigerant regulation. The sensor signals an excessive refrigerant pressure during heat pump operation. Contact the after-sales service.
E02	The LP pressure switch has detected an abnormality in the refrigerant regulation. The sensor signals a low refrigerant pressure during heat pump operation. Contact the after-sales service.
E03	Faulty contact in the flow sensor. Solution: -Check the calibration of the water inlet and outlet valves and the water pressure in your system must be greater than 0.9 bar -Make sure the flow sensor wires are connected to the electronic board, to test it, disconnect the wires and then reconnect them. -Close the hydraulic valves, remove the flow switch, clean the inside of the flow switch if it is dirty or has any limescale in it Apply pressure to the detector vane to trigger the contact manually and simulate the flow of water, if the error code disappears after one minute of maintained pressure, it means the flow sensor is working, otherwise, if the error code remains set, replace the flow sensor
E04	The LP&HP pressure switches have detected an abnormality in the refrigerant regulation. The sensors are malfunctioning due to not enough refrigerant in the heat pump. Contact the after-sales service.
E08	The connection between the control box and the heat pump is not working. Solution: -Make sure the control wires are connected to the electronic board in place: "12V brown wire - NET blue wire - GND green & yellow wire" -Check the connection of the remote command wire connection If this does not resolve the fault, replace the control box
P01	Fault in the water inlet temperature sensor. Solution: -Check the calibration of the water inlet and outlet valves -Make sure the sensor wires are connected to the electronic board -Check that the sensor is correctly installed on the hydraulic heat exchanger -Check the condition of the sensor, make sure that the cable is not damaged or cut after the checks, if the error code remains set, replace the sensor
P02	Fault in the water outlet temperature sensor. Solution: -Check the calibration of the water inlet and outlet valves -Make sure the sensor wires are connected to the electronic board -Check that the sensor is correctly installed on the hydraulic heat exchanger -Check the condition of the sensor, make sure that the cable is not damaged or cut after the checks, if the error code remains set, replace the sensor

<p>P03/P04</p>	<p>Fault in the ambient air temperature sensor. Solution: -Make sure the wires are properly connected to the electronic board -Check that the sensor is correctly fitted on the machine's rear grill -Check the condition of the sensor, make sure that the cable is not damaged or cut after the checks, if the error code remains set, replace the sensor</p>
<p>P05</p>	<p>Fault in the refrigerant evaporation temperature sensor in the copper lug at the bottom of the evaporator. Solution: -Make sure the wires are properly connected to the electronic board -Check that the probe is well installed on the terminal at the bottom of the evaporator -Check the condition of the sensor, make sure that the cable is not damaged or cut after the checks, if the error code remains set, replace the sensor</p>
<p>P06</p>	<p>Significant temperature difference between the water inlet and the water outlet or fault in the electronic board PCB Solution: -Check the setting of your water inlet and outlet valves -Check the water inlet and outlet sensors (see error codes P01/P02) -Water flow rate too low or flow switch is stuck in the closed position. (see error code E03) After the checks, if the error code remains set, replace electronic board PCB</p>
<p>P07</p>	<p>Fault in the air intake temperature sensor. Solution: -Make sure the wires are connected to the electronic board -Check the condition of the sensor, make sure that the cable is not damaged or cut -After the checks, if the error code remains set, replace the temperature sensor -If there is no sensor in this location and the error code remains set, install a 6.8 kΩ resistor</p>

If you encounter a fault with an F code, please contact our technical service.

6. Maintenance and guarantee

Maintenance is mainly about keeping your machine in good condition so that it does not give you any problems.

6.1 Maintenance to be done

Clean the evaporator: Use a water jet, making sure to keep the jet in the direction of the fins, from top to bottom. The evaporator aluminium fins should be cleaned regularly to ensure a good airflow.

Regularly clear the condensate outlets to prevent the accumulation of water within the chassis. Otherwise, the fan blades may be attacked and damaged by the acidity of the water. This will not affect the correct operation of your machine, but we recommend that you clean the evaporator to stop the process.

6.2 Wintering

Winterisation is mandatory at the end of the period of use to prevent any damage.

- Shut off power to the machine at the circuit breaker,
- Open the By-Pass valve, close the inlet and outlet water valves,
- Unscrew the inlet and outlet connections of your heat pump,
- Purge your hydraulic system,
- Leave about 5 cm between the connections and the machine during the winter season.

6.3 On-site servicing

As part of the guarantee, the manufacturer may carry out an on-site service or request the return of the heat pump. **Only the manufacturer may make the decision to carry out an on-site service.**

This operation may be covered under the guarantee, depending on the invoice date and the type of fault.

Outside the guarantee period, or in the event of a failure not covered by the guarantee, the manufacturer may offer an on-site service. The customer must accept a quote in advance.

No after-sales service interventions will change the guarantee period.

6.4 EASYPAC manufacturer's guarantee

The manufacturer's guarantee is for 3 years. As well as this parts guarantee, labour costs are included only if the equipment is returned to our workshops. If the heat pump has to be returned, the transport costs are the responsibility of the customer for the transport to our workshops, and of the manufacturer for the return transport costs.

The guarantee may not be honored if:

Your heat pump has not been installed using best practice, following the recommendations described in this manual.

Routine maintenance has not been carried out, especially the cleaning of the evaporator and the condensate outlets. There should not be any standing water within the chassis.

The damage is due to improper installation, bad connections, or an incorrect placement of the installation.

The damage or repairs are the result of misuse, abuse, improper repairs, unauthorised modifications or third-party equipment faults.

The damage is due to flooding, wind, fire, lightning, accidents, corrosive atmospheres or other conditions beyond your dealer's control.

Parts have been replaced by parts that are not supplied or approved by your dealer.

The damage is to persons or property of any kind whatsoever, including any direct, indirect, special or consequential damage resulting from the use or loss of use of the product.

Limitation :

This guarantee is exclusive and replaces all other implied warranties of merchantability or fitness for a particular purpose and any other explicit or implied guarantees. The indemnifications provided for in this guarantee are exclusive and are Warmpac's only obligation, any other claim made by any person will have no effect.

6.5 Safety advice

- Do not touch the fan when it is running, it could hurt you,
- Keep children well clear of the equipment,
- Regularly check the power supply and connection cables of your heat pump. If you have any doubt, contact your installer,
- For after-sales service, you must use the original manufacturer parts.