

Exploded Diagram

Model and code:(DC35 10160037)

1 Complete machine structure explosion diagram

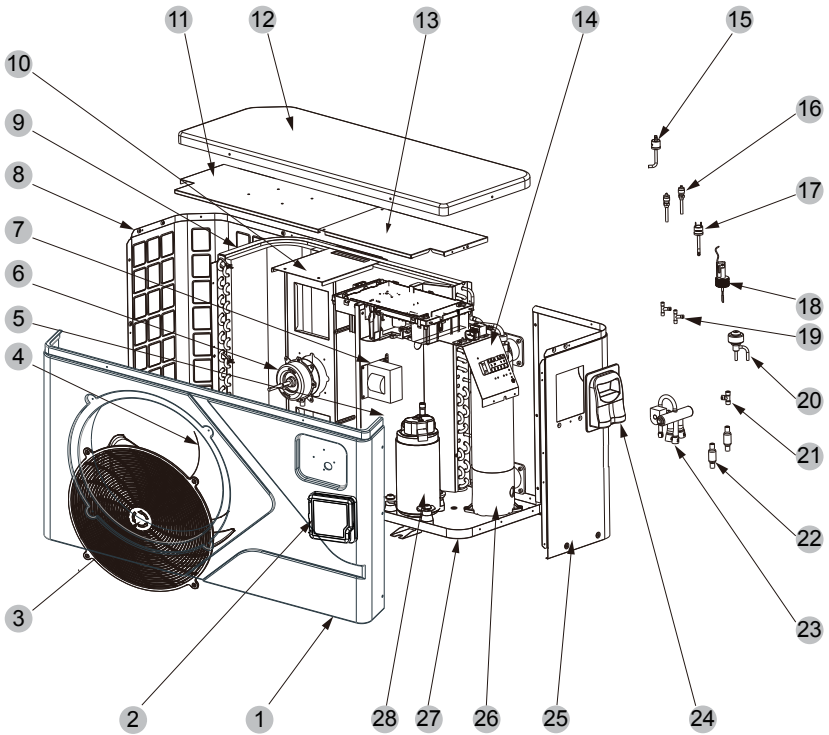

2 Electrical control structure explosion diagram

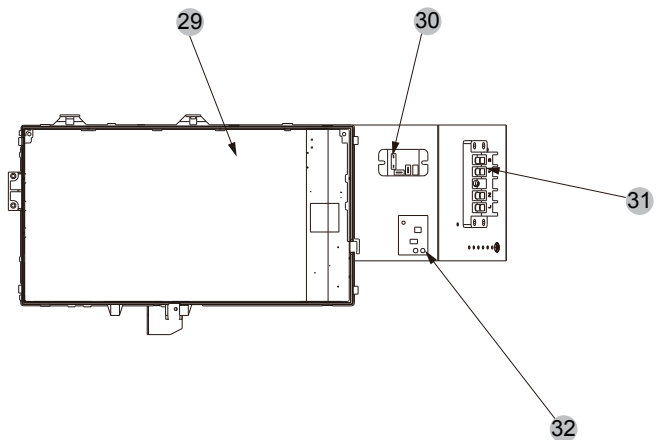

Exploded Diagram

No.	Code	Name	Specifications	Qty
1	80900253	Front frame	ABS	1
2	72200077	CM404	82300028+82400072	1
3	20000-220245	Plastic fan net	Φ461 ABS+30%GF	1
4	301030-00000006	Axial fan blades	Φ405×134-Φ8(7)×3	1
5	80700215	Median septum	Galvanized plate	1
6	80200018	Dc motor	ZWS40-E51	1
7	82500006	Reactor	R1650FNKZ 16A 50Hz 5mH	1
8	80700705	After the network	Galvanized plate	1
9	301060-20250002	Finned heat exchanger	650×245×550×Φ7×1 片距1.5	1
10	80700218	Motor bracket	Galvanized plate	1
11	80702344	Top support plate	Galvanized plate	1
12	80900254	Top	ABS	1
13	80702345	Top support plate	Galvanized plate	1
14	80701502	Electrical box support plate	Galvanized plate	1
15	20000-360157	Pressure switch	0.30MPa/0.15MPa ±0.05 NO	1
16	20000-140150	Needle valve	40mm 1/2"	2
17	2001-3605	Pressure switch	3.2MPa/4.4MPa ±0.15 NC	1
18	83000068	Water flow switch	PSL-1 3/4	1
19	2000-1460	There-way valve	Φ6.5-2×Φ6.5(T)×0.75 T2M	2
20	81000011	Electronic expansion valve	DPF(B)1.65C-007	1
21	304030-00000002	There-way valve	Φ9.52-2×Φ6.35(T)×1.0	1
22	20000-140178	Filter	Φ9.7-Φ9.7(Φ19) T2M	2
23	2004-1437	Four-way valve	SHF-9H-35U-P/C03C01S	1
24	32009-220029	Junction box body	ABS	1
25	80700704	Right side of the plate	Galvanized plate	1
26	80600037	Titanium tube heat exchanger	Φ9.52×5m Φ110	1
27	80705319	Chassis	Galvanized plate	1
28	80100108	Compressor	9RD138ZFB21	1
29	72200094	Variable frequency controller	82300052+82400021	1
30	20000-360297	Relay	HATF903AS30AC220 AC220V 30A	1
31	4000-3901	5 bit wiring block	RS9101C-5(450V~ 4mm ²)(L、N、PE、1、2)	1
32	82600008	Switching power supply	EPS-15-12	1